

FROMM

OPERATION MANUAL / SPARE PARTS LIST

**MANUAL SEALLESS
STEEL STRAPPING TOOL**

MODEL A337.0001

13.1872.01

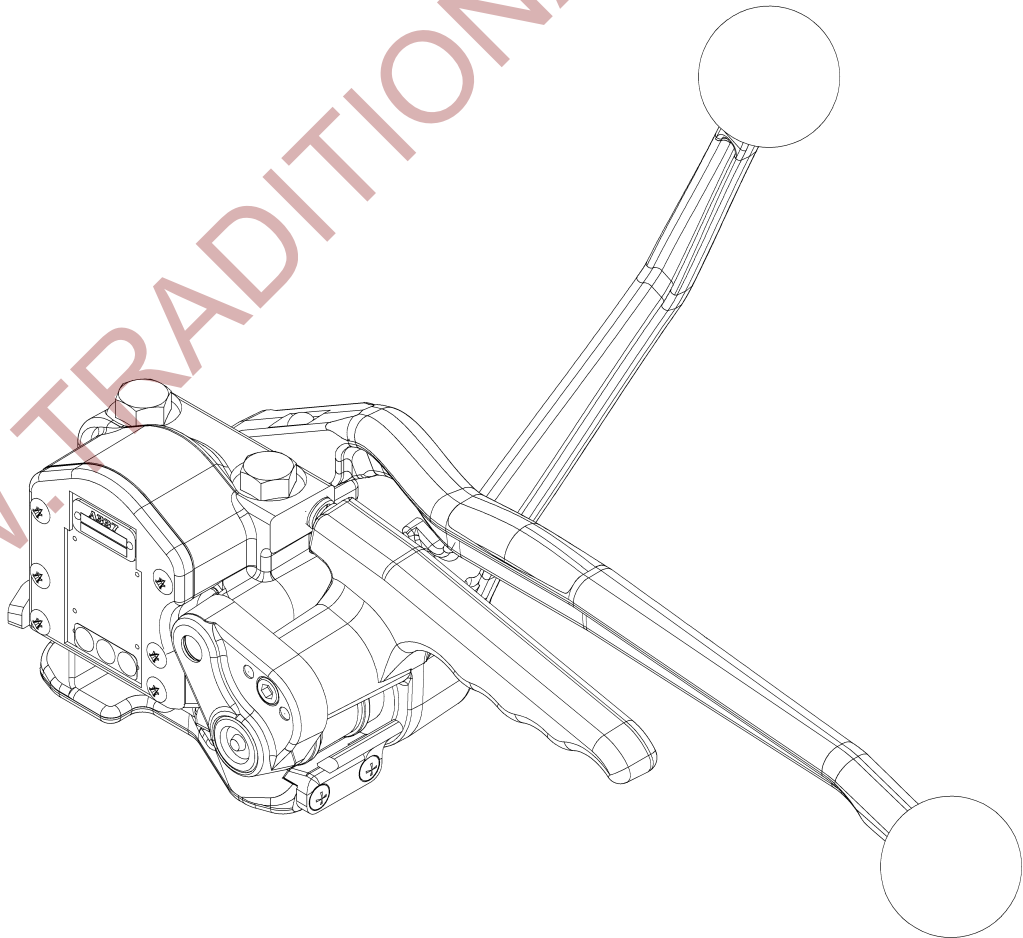

	INDEX	PAGE
1	SAFETY INSTRUCTIONS	2
2	WARRANTY CONDITIONS AND LIABILITY	4
3	APPROPRIATE USE	4
4	TECNICAL DATA	4
5	CHART OF TYPES A337.0001	5
6	OPERATION LEVERS	6
7	OPERATION	6
8	SPARE PARTS LIST 13.1872.01	10
9	SEAL CONTROL	12
10	SEAL ADJUSTMENT	13
11	CLEANING	13
12	EXCHANGE OF WEARING PARTS	14

1 SAFETY INSTRUCTIONS

Read these instructions carefully. Failure to follow these instructions can result in severe personal injury.

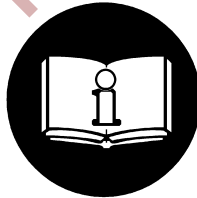

Eye injury hazard

Failure to wear safety glasses with side shields can result in severe eye injury or blindness. Always wear safety glasses with side shields which conform to ANSI Standard Z87.1.



Operation

Tool must not be used by persons not properly trained in their use. Before tensioning strap, read and understand the tool operating instructions. Failure to follow the operating instructions or improper load positioning could result in strap breakage.

Become familiar with your tool and keep fingers away from areas that can pinch or cut.

Joints

You are fully responsible to review the joints made by your tool. Become familiar with the seal control and seal adjustment described in this operation manual. Misformed joints may not secure the load and could cause serious injury. Never handle or ship any load with improperly formed joints.

Dispensing strap

Only dispense strap from a dispenser specifically designed for strap.
Tuck strap end back into dispenser when not in use.

Protective gloves

When handling strap, always wear protective gloves.

**Strap warnings**

Never use strap as a means of pulling or lifting loads. Failure to follow these warnings can result in severe personal injury.

Strap breakage hazard

Improper operation of the tool, excessive tensioning, using strap not recommended for this tool or sharp corners on the load can result in a sudden loss of strap tension or in strap breakage during tensioning, which could result in the following:

- A sudden loss of balance causing you to fall.
- Both tool and strap flying violently towards your face.

Note as follows:

- If the load corners are sharp, use edge protectors.
- Place the strap correctly around a properly positioned load.
- Positioning yourself in-line with the strap, during tensioning and sealing, can result in severe personal injury from flying strap or tool. When tensioning or sealing, position yourself to one side of the strap and keep all bystanders away.
- Use the correct strap quality, strap width, strap gauge and strap tensile strength recommended in this manual for your tool. Using strap not recommended for this tool can result in strap breakage during tensioning.

Cutting tensioned strap

When cutting strapping, use the proper strapping cutter and keep other personnel and yourself at a safe distance from the strap. Always stand to side of the strap, away from the direction the loosened strap end will fly. Use only cutters designed for strap and never hammers, pliers, hacksaws, axes, etc.

Fall hazard

Keep your working area tidy. Untidiness of your working area may cause a risk of injury. Maintaining improper footing and/or balance when operating the tool can cause you to fall. Before tensioning and especially in elevated areas, always establish good balance. Both feet should be securely placed on a flat, solid surface, especially when working in elevated areas. Do not use the tool when you are in an awkward position. Pay attention to the rules and regulations for preventions of accident which are valid for the work place.

Tool hazards

A well maintained tool is a safe tool!

Check tool regularly for broken or worn parts. Do not operate a tool with broken or worn parts.

Never modify any tool. Modification can result in severe bodily injury.

2 WARRANTY CONDITIONS AND LIABILITY

FROMM Holding AG warrants all its strapping tools and machine heads during a period of 24 months from the date of installation at the end-user's sight by the distributor, however, not later than 30 months from the date of shipment to the distributor of FROMM Holding AG.

The warranty includes all deficiencies clearly resulting from poor manufacturing or faulty materials. Damage claims as a result of production shutdowns and claims for damage to persons and to property resulting from warranty deficiencies cannot be asserted by the customer.

The warranty excludes:

- wearing parts
- deficiencies resulting from improper installing, incorrect handling and maintaining the tool
- deficiencies resulting from using the tool without or with defective security- and safety devices
- disregard of directions in the operation manual
- arbitrary modifications of the tool
- deficient control of wearing parts
- deficient repair works of the tool
- Use of consumable products not recommended by FROMM Holding AG

We reserve the right to modify the product at any time in order to improve its quality.

3 APPROPRIATE USE

The tool model A337 has been designed to strap packages with steel strapping exclusively.

The warranty / liability excludes:

- non appropriate use of the tool,
- disregard of directions in the operation manual,
- disregard of control- and maintenance instructions.

4 TECHNICAL DATA

Dimensions without suspension bracket

	Tool:	Package:
Length:	430 mm / 16.9"	730 mm / 28.7"
Width:	160 mm / 6.3"	230 mm / 9.1"
Height:	315 mm / 12.4"	180 mm / 7.1"
Weight:	4.45 kg / 9.8 lbs	1.67 kg / 3.8 lbs

Tensioning force

4 kN / 900 lbs (270 N / 60 lbs manual force)

Sealing force

The manual force required for sealing is approx. 200 N / 45 lbs.

Joint strength

Approx. 80% of the strap's tensile strength.

Steel strapping

Width:	9.5 - 20 mm / 3/8 - 3/4" (see chart of types)
Thickness:	0.38 - 0.63 mm / .015 - .025" (see chart of types)
Quality:	Fundamentally the A337 allows the use of all current steel straps with tensile strengths ranging from 700 to 1100 N/mm ² / 100 000 - 160 000 psi (see chart of types). Straps with a low breaking elongation are unsuitable.

5 CHART OF TYPES A337.0001

Item No.	Model	Strap width	Strap thickness
13.1850	A337/9.5/0.38-0.50	9.5mm / 3/8"	0.38-0.50mm / .015-.020"
13.1860	A337/10/0.38-0.50	10.0mm	0.38-0.50mm / .015-.020"
13.1870	A337/12.7/0.38-0.50	12.7mm / 1/2"	0.38-0.50mm / .015-.020"
13.1872	A337/12.7/0.50-0.63	12.7mm / 1/2"	0.50-0.63mm / .020-.025"
13.1880	A337/13/0.38-0.50	13.0mm	0.38-0.50mm / .015-.020"
13.1882	A337/13/0.50-0.63	13.0mm	0.50-0.63mm / .020-.025"
13.1890	A337/16/0.38-0.50	16.0mm / 5/8"	0.38-0.50mm / .015-.020"
13.1892	A337/16/0.50-0.63	16.0mm / 5/8"	0.50-0.63mm / .020-.025"
13.1910	A337/19/0.38-0.50	19.0mm / 3/4"	0.38-0.50mm / .015-.020"
13.1912	A337/19/0.50-0.63	19.0mm / 3/4"	0.50-0.63mm / .020-.025"
13.1920	A337/20/0.38-0.50	20.0mm	0.38-0.50mm / .015-.020"
13.1922	A337/20/0.50-0.63	20.0mm	0.50-0.63mm / .020-.025"

Accessories

Item No.	Designation	Remarks
N4.1411	Hexagon socket screw key	Delivered with the machine.
A33.0121	Susp. bracket for vertical and horizontal operation	To be ordered separately in case of need.
A33.0122	Tang for horizontal operation	To be ordered separately in case of need.

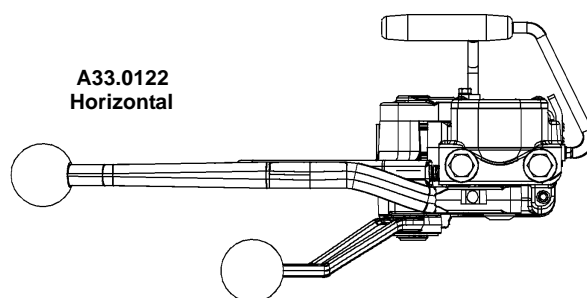
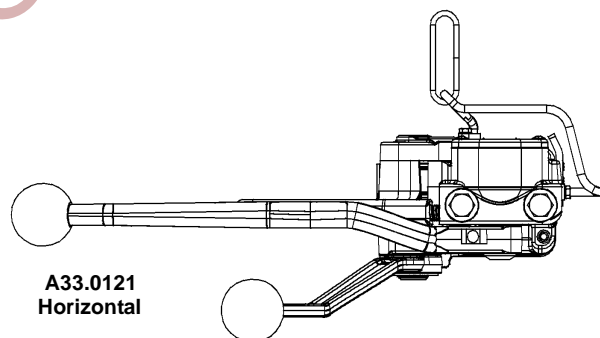
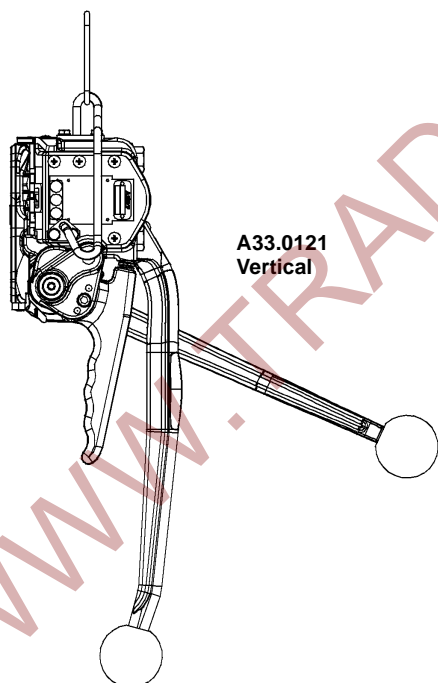

6 OPERATION LEVERS

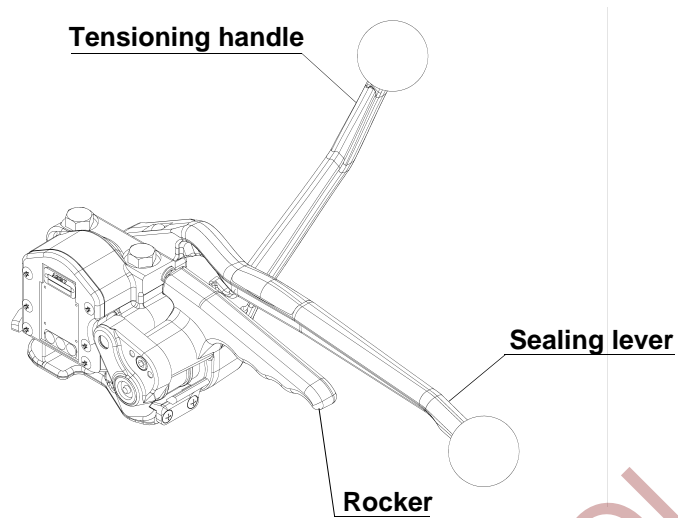

7 OPERATION

Feeding the strapping around the package

The strapping is fed around the package in the direction as shown in the illustration. The strapping end is held tightly with the left hand and pulled firmly towards the operator with the right hand.

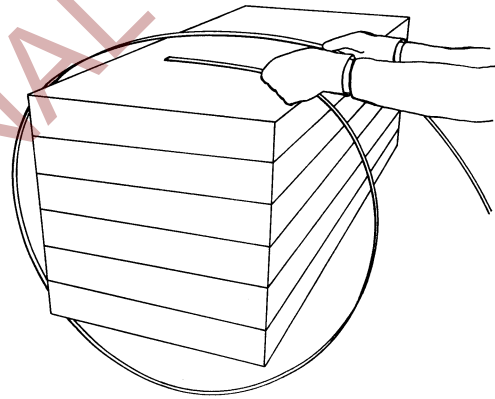

Loading the strapping

The rocker is raised with the right hand. The left hand inserts the two straps lying precisely upon another into the tool until they hit the strap stops.

The lower strap end must slightly protrude the end of the base plate.

Be certain that the strapping is held by the strap guide.

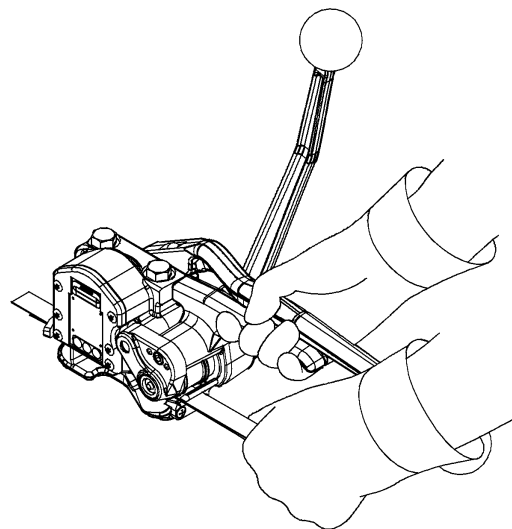

Tensioning the strapping

The tool is held tightly with the left hand being placed on the sealing lever. The tensioning handle is now moved forward and backward with the right hand until the desired tension is attained.

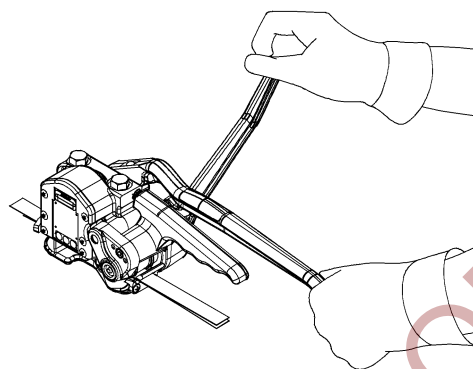

Sealing the strapping

The sealing lever is moved forward using the left hand until it hits the stop. The lever is then moved back to its initial position. When sealing, the right hand absorbs the sealing force by holding the tensioning handle.

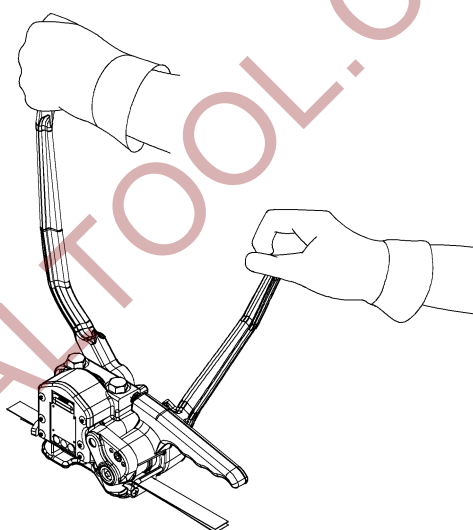

Releasing the tool

Hold the cut off strap end with the left hand, lift the rocker with the right hand and push the tool from the applied strap to the right.

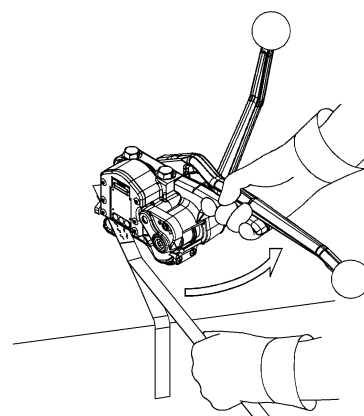

Releasing the feed wheel after faulty operation

If the feed-wheel is jammed with the strap and the rocker cannot be released the following procedure is necessary to remove the strapping from the tool:

- loosen screws N1.1571 and N11.1126.
- lift rocker and remove steel strapping from the tool.
- retighten screws N1.1571 and N11.1126 with a torque of 90 resp. 110 Nm (800 resp. 970 lbs).

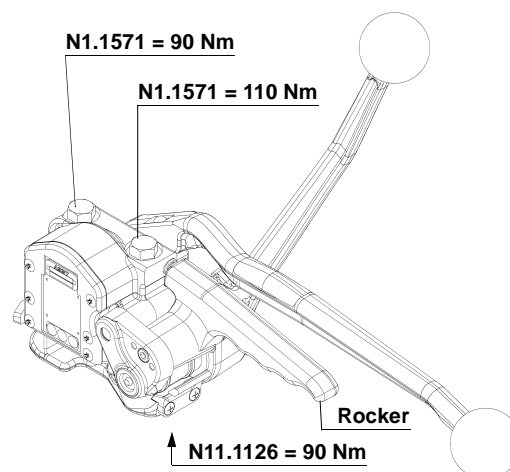

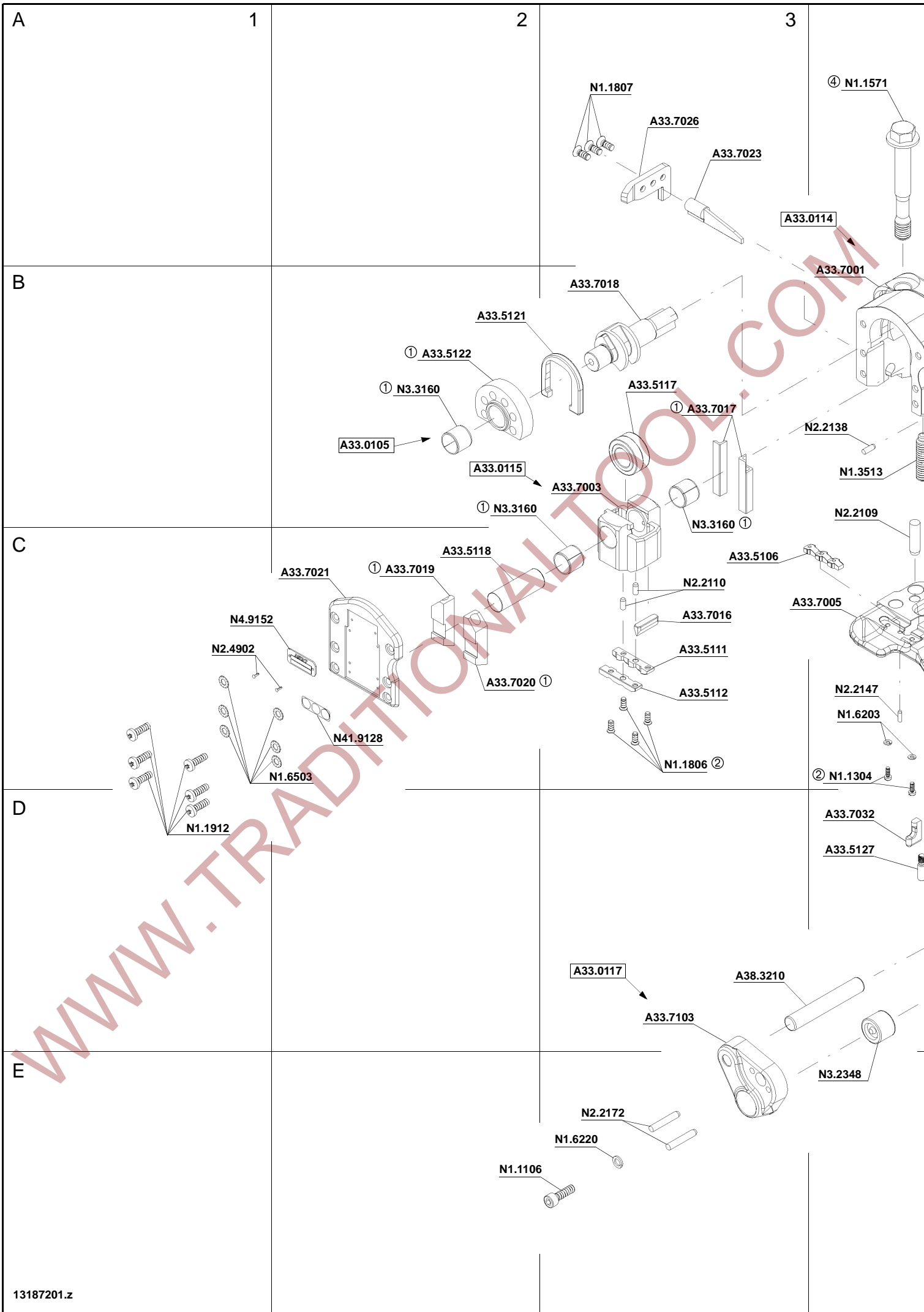

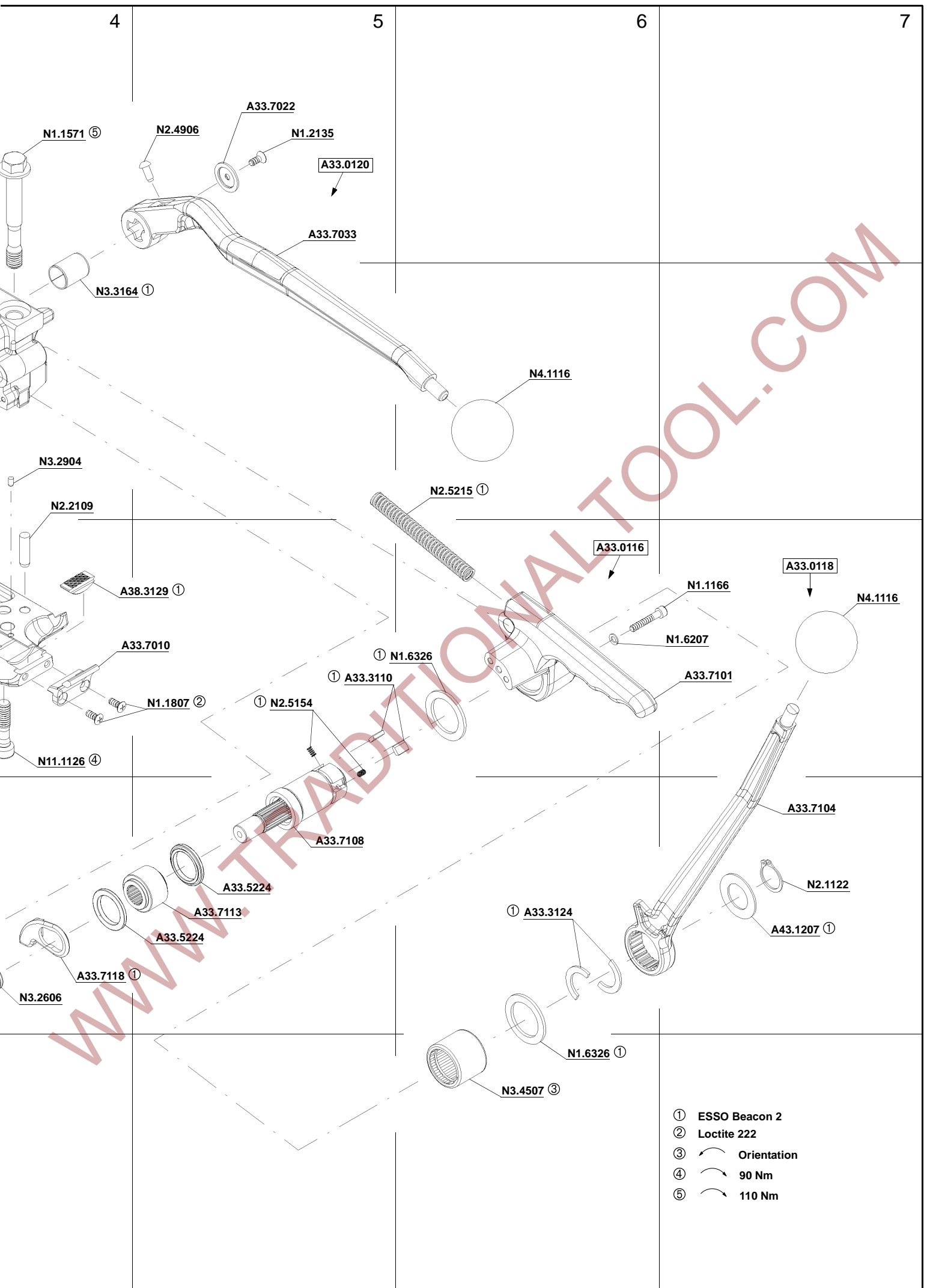

8 SPARE PARTS LIST 13.1872.01

13.1872.01	A337/12.7/0.50-0.63		A337.0001.01		29.02.00	
Item-No.		in group	Pcs.	Description	Dimension	Field
[A33.0105]			1	BEARING PICK-UP ATTACHMENT		B2
[A33.0114]			1	SEALING HOUSING		A4
[A33.0115]			1	DIE AND CUTTER SUPPORT		B2
[A33.0116]			1	ROCKER		C6
[A33.0117]			1	END COVER		D3
[A33.0118]			1	TENSION HANDLE		C7
[A33.0120]			1	SEALING HANDLE		A5
A33.3110			2	TENSIONING PAWL		C5
A33.3124			2	RING HALF		D6
A33.5106	*		1	PUNCH		C3
A33.5111	*		1	DIE HALF		C3
A33.5112	*		1	DIE HALF		C3
A33.5117			1	ROLLER		B3
A33.5118			1	PARALLEL PIN		C2
A33.5121			1	EYE		B2
A33.5122		A33.0105	1	BEARING PICK-UP ATTACHMENT		B2
A33.5127			1	EJECTOR SCREW		D4
A33.5224			2	SPACER RING		D5
[A33.7001]		A33.0114	1	SEALING HOUSING		B4
A33.7003		A33.0115	1	DIE AND CUTTER SUPPORT		B3
A33.7005			1	BASE PLATE		C4
A33.7010			1	HOLDER		C5
A33.7016	*		1	CUTTER		C3
A33.7017			2	GUIDE GIB		B3
A33.7018			1	ECCENTRIC SHAFT		B3
A33.7019			1	GUIDE GIB		C2
A33.7020			1	GUIDE GIB		C2
A33.7021			1	SIDE PLATE		C2
A33.7022			1	COVER DISK		A5
A33.7023			1	EJECTOR		A3
A33.7026			1	STRAP STOP		A3
A33.7032			1	EJECTOR		D4
A33.7033		A33.0120	1	SEALING HANDLE		A5
[A33.7101]		A33.0116	1	ROCKER		C7
A33.7103		A33.0117	1	END COVER		D3
A33.7104		A33.0118	1	TENSION HANDLE		D7
[A33.7108]			1	TENSION SHAFT		D5
A33.7113	*		1	TENSIONING WHEEL		D5
A33.7118			1	STRAP GUIDE		D4
A38.3129	*		1	GRIPPER		C5
A38.3210			1	PIVOT PIN		D3
A43.1207			1	DISK		D7
N11.1126			1	SCREW	M10 X 1 X 39	C4
N1.1106			1	SCREW	M6 X 20	E2
N1.1166		A33.0116	1	SCREW	M5 X 30	C7
N1.1304			2	SCREW	M3 X 8	C4
N1.1571			2	HEXAGON SCREW	M12 X 1.25 X 90	A4
N1.1806			4	SCREW	M4 X 10	C3
N1.1807			5	SCREW	M5 X 12	A3+
N1.1912			6	FLAT HEAD SCREW	M5 X 16	D1
N1.2135			1	COUNTERSUNK SCREW	M5 X 12	A5

[] = Group

* = Wearing parts

13.1872.01	A337/12.7/0.50-0.63		A337.0001.01			29.02.00
Item-No.		in group	Pcs.	Description	Dimension	Field
N1.3513			1	SOCKET SET SCREW	M10 X 40	B4
N1.6203			2	SPRING LOCK WASHER	M3	C4
N1.6207		A33.0116	1	SPRING LOCK WASHER	M5	C7
N1.6220			1	SPRING LOCK WASHER	M6	E3
N1.6326			2	SUPPORTING DISK	30 X 42 X 2.5	C6+
N1.6503			6	SAFETY WASHER	M5	C2
N2.1122			1	SECURITY RING	E21	D7
N2.2109			2	PARALLEL PIN	8 m6 X 30	B4
N2.2110		A33.0115	2	PARALLEL PIN	4 m6 X 10	C3
N2.2138			1	PARALLEL PIN	4 m6 X 12	B4
N2.2147			1	PARALLEL PIN	3 m6 X 10	C4
N2.2172		A33.0117	2	PARALLEL PIN	5 m6 X 30	E3
N2.4902			2	HAMMER HEAD BOLT	1.85 X 4.76	C1
N2.4906		A33.0120	1	HAMMER HEAD BOLT	5,31 X 12,7	A5
N2.5154			2	PRESSURE SPRING	0.45 X 3.9 X 7	C5
N2.5215			1	PRESSURE SPRING	2,25X11,75X125	B6
N3.2348		A33.0117	1	NEEDLE CASE		E4
N3.2606		A33.0117	1	PACKING RING		D4
N3.2904			1	PIN	4 X 8	B4
N3.3160		A33.0105	1	SLIDE-BEARING		B2
N3.3160		A33.0115	2	SLIDE-BEARING		B2+
N3.3164		A33.0114	1	SLIDE-BEARING		B4
N3.4507		A33.0116	1	NEEDLE FREE WHEELING		E6
N41.9128			1	ADHESIVE LABEL		C2
N4.1116		A33.0118	1	GRIP BALL		C7
N4.1116		A33.0120	1	GRIP BALL		B6
N4.1411			1	SOCKET WRENCH	5 mm	--
N4.9152			1	NUMBER PLATE	A337	C1

[] = Group

* = Wearing parts

9 SEAL CONTROL

A regular control of the seal is necessary. The seal can be checked visually and the person controlling can easily judge the quality of the seal. When checking the seal the following illustrations must be compared.

Correct seal

A correct seal must conform to the illustration. This means that the depth with which the upper strap hooks into the lower one must be 1 – 1.5 mm (0.039 – 0.059”) in min. and must not exceed 2 mm (0.079”). The upper strap must be sheared clean and the cutter must not leave scratch marks on the lower strap.

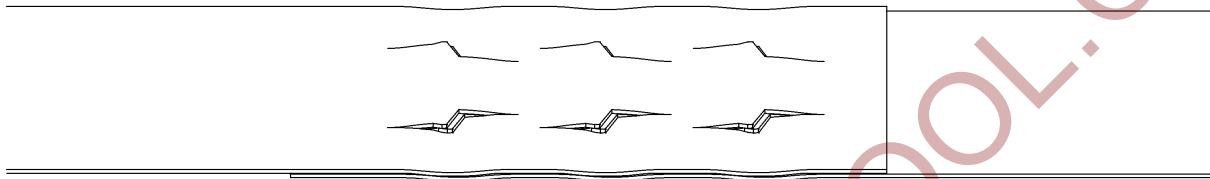

Incorrect seal (the sealing mechanism is adjusted too high)

This stamped seal is not deep enough and the upper strap is not sheared. The tensile strength of this seal is insufficient and the strapping must be taken away from the package. The tool must be readjusted immediately (see SEAL ADJUSTMENT).

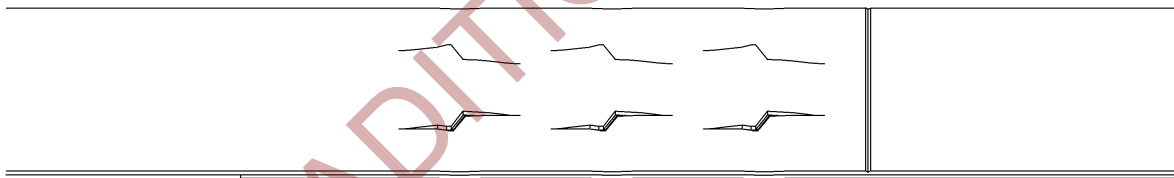

Incorrect seal (the sealing mechanism is adjusted too low)

This stamped seal is too deep and the lower strap is scratched by the cutter. Although the tensile strength of this seal is sufficient the strapping must be taken away from the package because of the scratched lower strap. The tool must be readjusted immediately (see SEAL ADJUSTMENT).

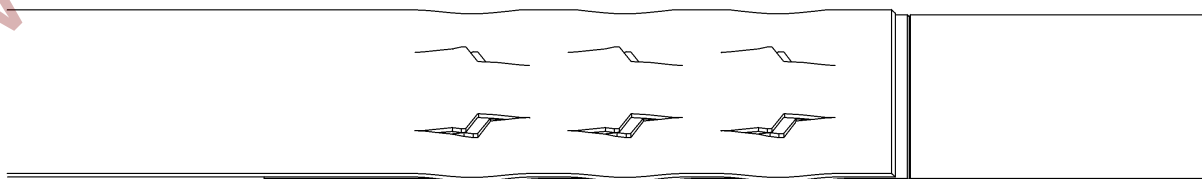

10 SEAL ADJUSTMENT

The sealing- and cutting depth of the sealing mechanism and the cutter can be adjusted by using a hexagon key N4.1411 (size 5 mm) and turning the adjustment screw infinitely variable. The hexagon key N4.1411 is supplied with the tool.

Sealing depth is excessive

Turning the adjustment screw in a clockwise direction reduces the sealing depth.

Sealing depth is insufficient

Turning the adjustment screw in a counter clockwise direction increases the sealing depth.

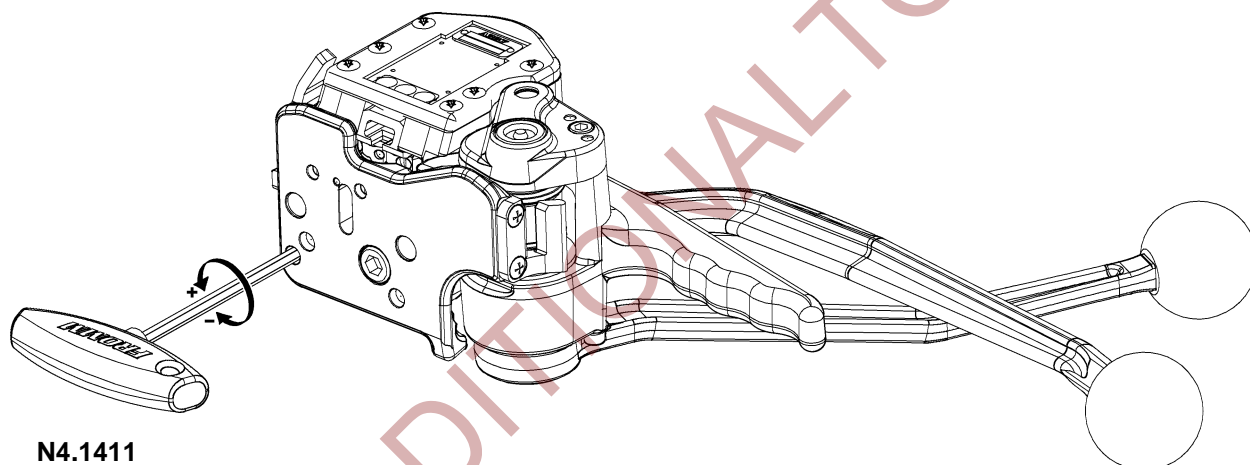

11 CLEANING

In case of heavy dirt and when painted straps are used the punch, dies, gripper and feed-wheel must be cleaned regularly.

Normally it is sufficient to blow out the parts with the help of an air gun.

12 EXCHANGE OF WEARING PARTS

Exchange of the feed wheel and the gripper

- Disassemble cylinder screw in the end plate.
- Lift the rocker and remove end plate, strap guide, supporting disk and feed wheel from the tension shaft.
- Unscrew holder and remove it together with the gripper from the base plate.
- Fitting in opposite order.

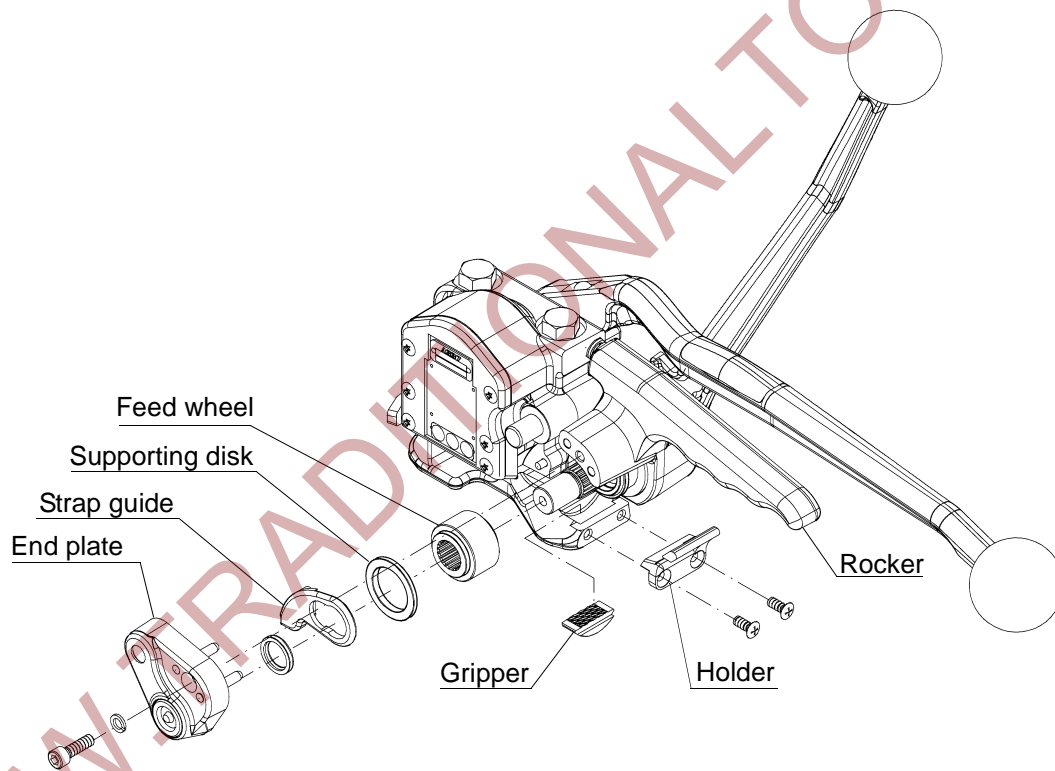

Important!

The fastening screw for the holder has to be secured with LOCTITE 222.

Observe assembling position of the feed wheel

Exchange of the punch, the dies and the cutter

- Disassemble the ejector and the ejector screw.
- Unscrew the strap stop and pull the upper ejector together with the strap stop out of the tool.
- Unscrew the side plate and disassemble both guide gibs.
- Slightly lift the sealing lever and remove bearing pick-up attachment, link and the die- and cutter piston from the sealing body.
- Clean all parts and replace the worn ones.
- Fitting in opposite order.

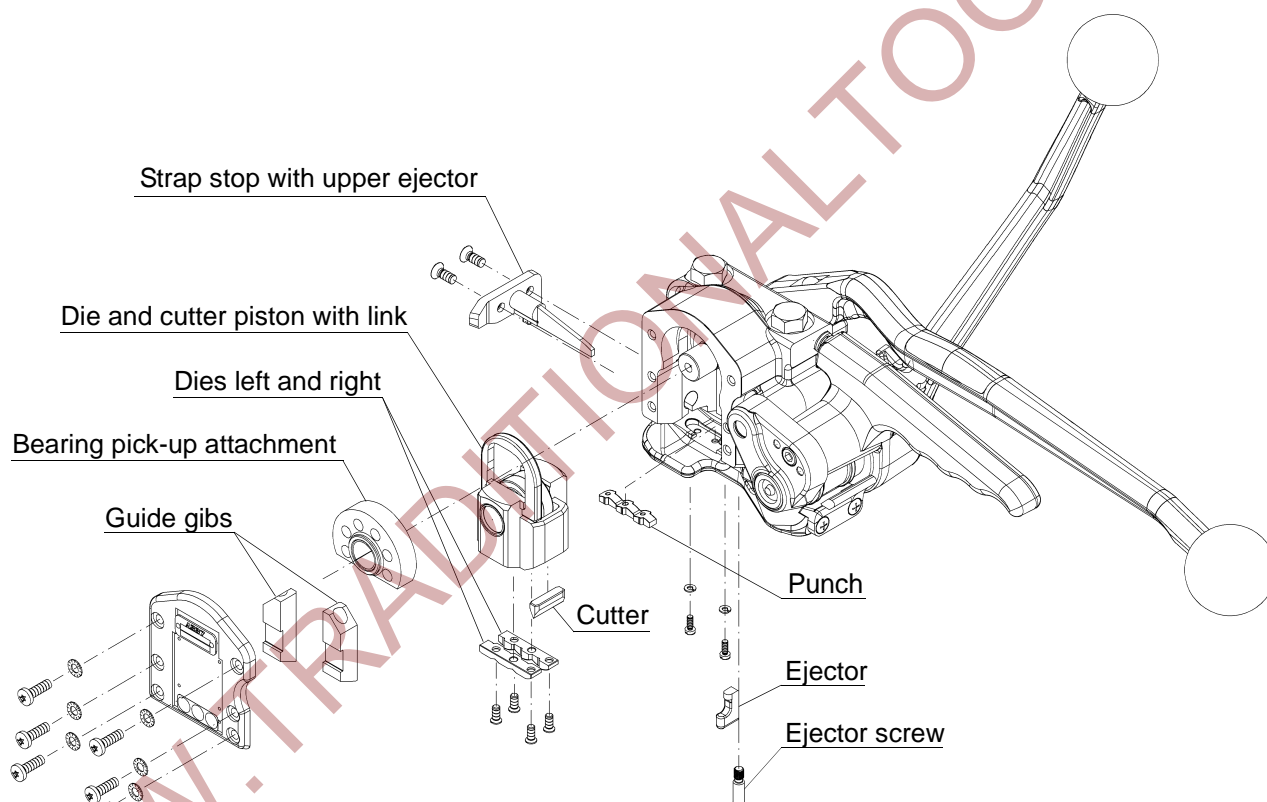

Important!

Bearing areas and guides have to be greased.

The fastening screws for the punch and the dies have to be secured with LOCTITE 222.

WWW.TRADITIONALTOOL.COM