

MUL-330

5/8" Heavy Duty PET Sealer

FOR PP/PET STRAP WITH ORP 2300 OR EQUIVALENT SEALS

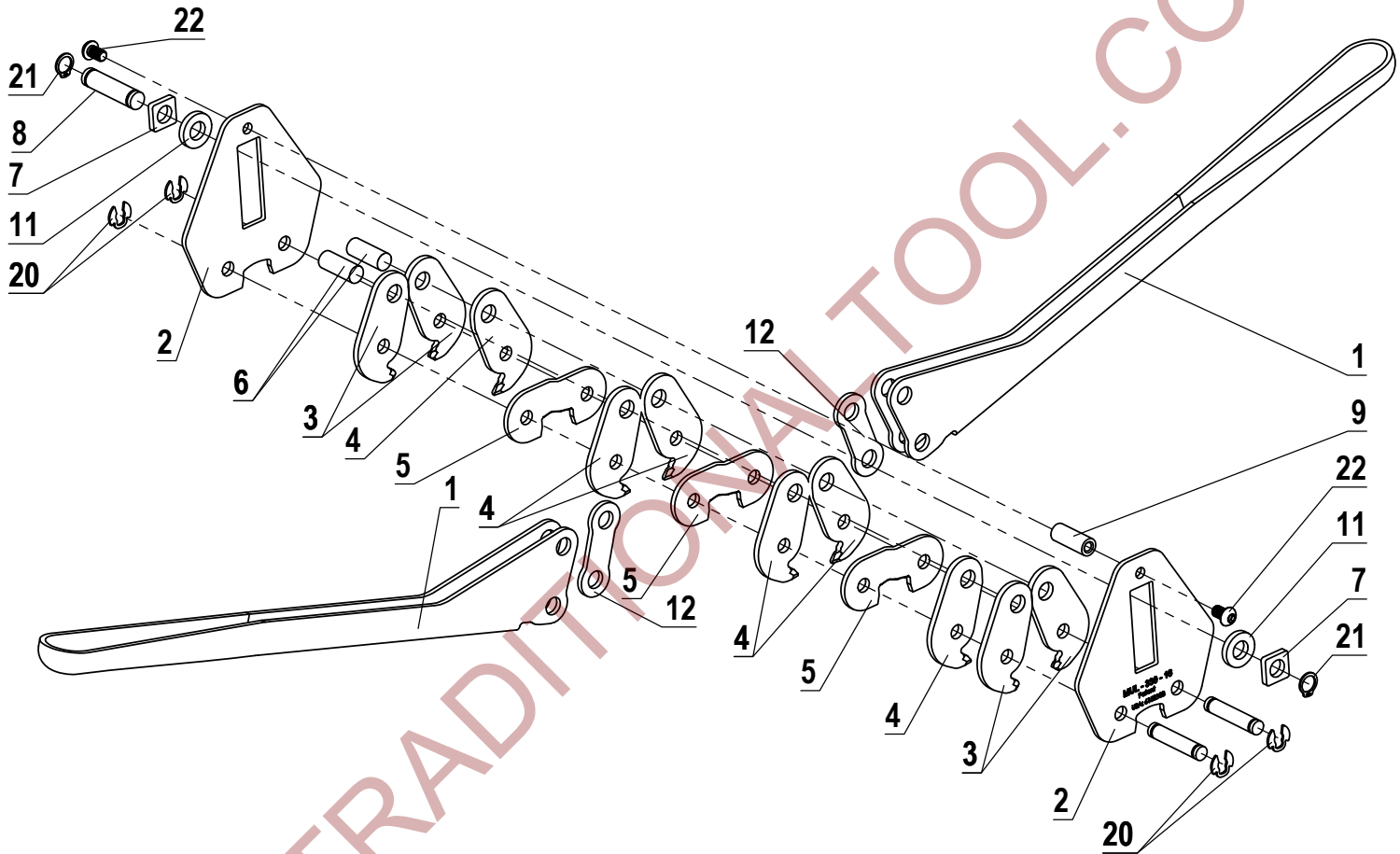

No	KEYNo	DESCRIPTION	QTY.	No	KEYNo	DESCRIPTION	QTY.
1	330-01	HANDLE	2	9	330-09	SPACER PIN	1
2	330-02	SIDE PLATE	2	10	330-10	ANVIL PIN	2
3	330-03	OUTER JAW	4	11	330-11	SLIDE RING	2
4	330-04	INNER JAW	6	12	330-12	ARM	2
5	330-05	ANVIL	3	20	330-20	KLIPRING 5/16"	4
6	330-06	JAW PIN	2	21	330-21	RETAINING RING 12	2
7	330-07	SLIDE PLATE	2	22	330-22	BUTTON HEAD CAP SCREW M6x10	2
8	330-08	SLIDE PIN	1				

MUL-330 Sealer for POLYESTER

Operation Manual

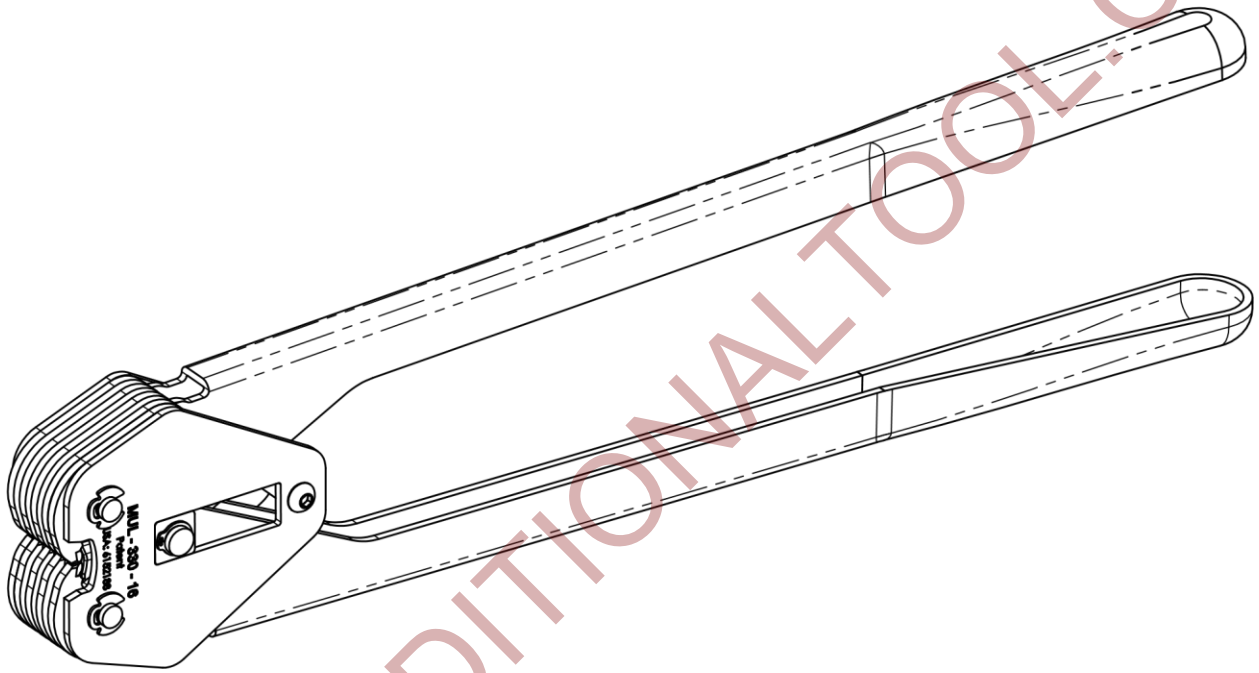

Strap Type	Polyester (PET)
Strap Width	5/8" (16 mm)
Strap Thickness	Up to 0.040" (1 mm)
Joint Type	Seal
Weight	4.5 lbs (2 kg)
Handle Length	17.5"

MUL-330 Operation Manual

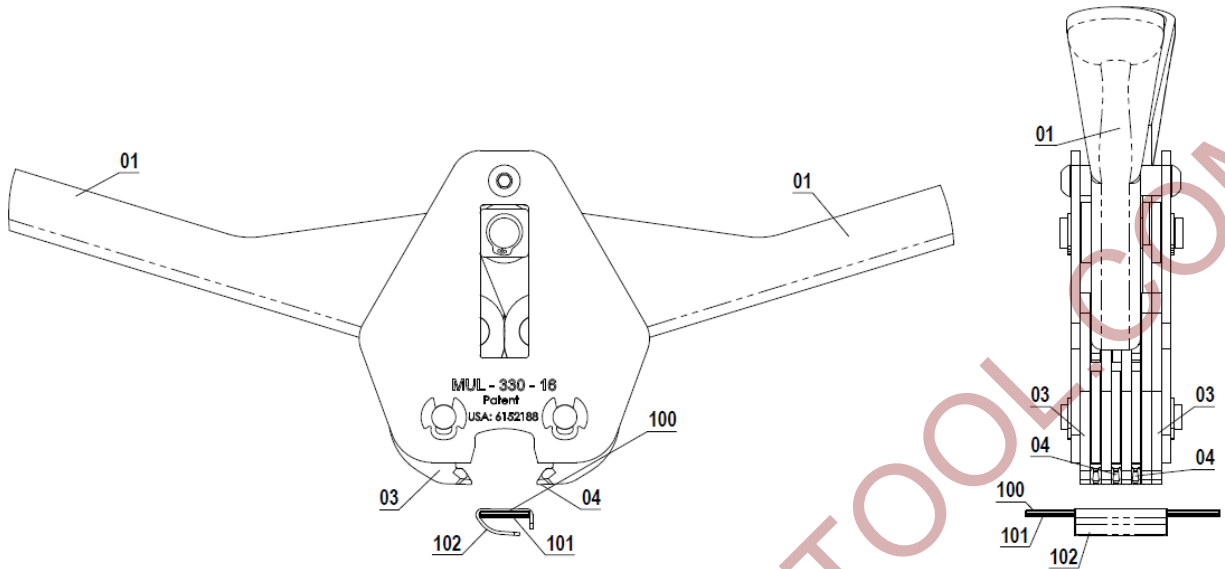

Fig. 1 – Starting Position

1. Place **Outer Jaws 03** and **Inner Jaws 04** of the tool across the middle of the **Seal 102** as shown on Fig. 2.

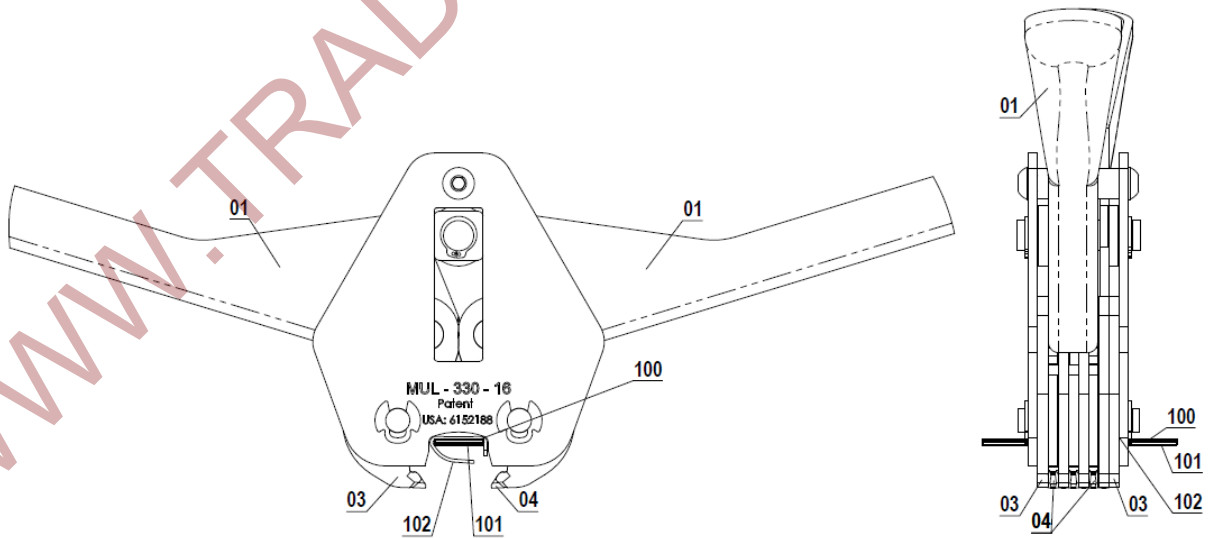

Fig. 2

2. Keeping the sealer in vertical position press the **Handles 01** together till they cannot be squeezed no further as shown on Fig. 3.

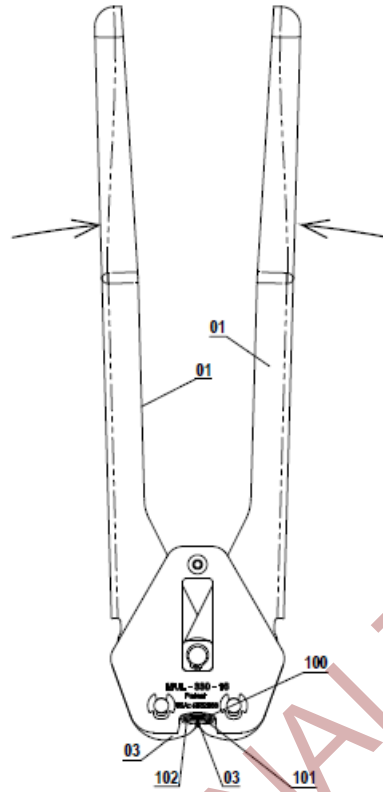

Fig. 3

3. Unclench the **Handles 01** and remove the sealer from the seal as shown on Fig. 4. The operation cycle is now complete.

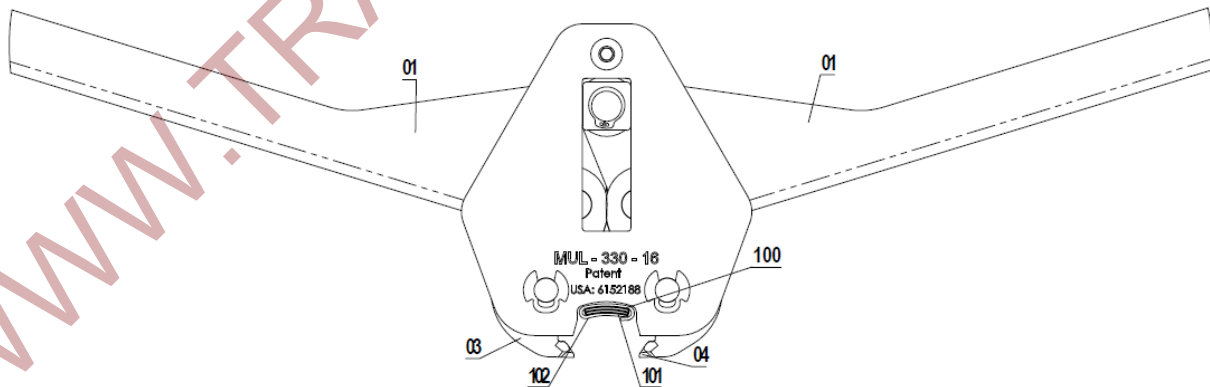

Fig. 4