

## **FROMM**

OPERATION MANUAL / SPARE PARTS LIST

**PNEUMATIC COMBINATION**

**PUSHER TYPE TOOL**

**AUTOMATIC**

**MODEL A483.0002**

13.4761.01

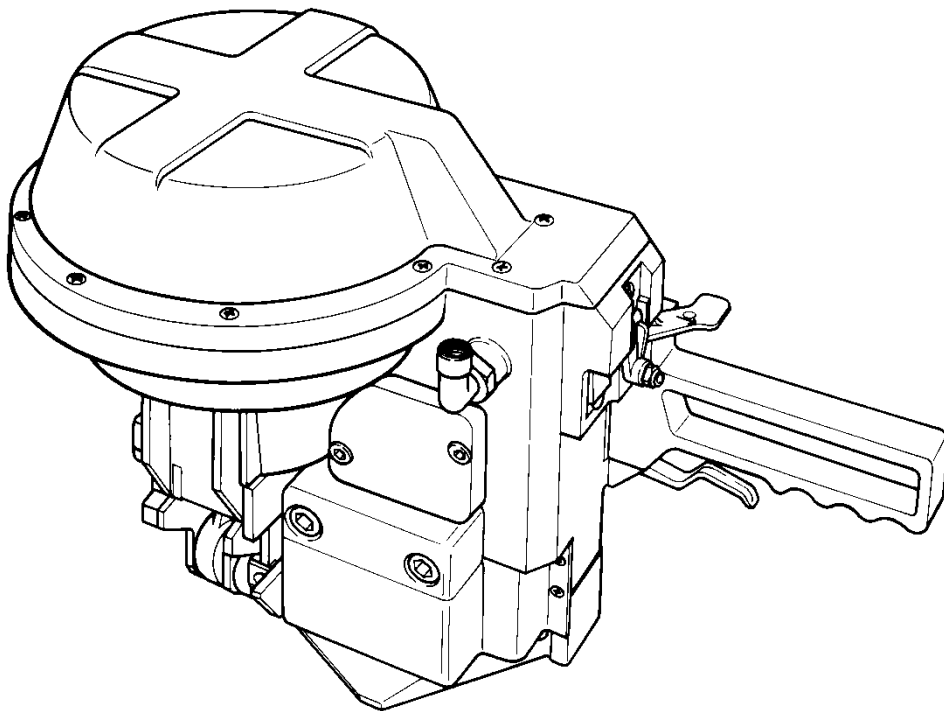

### **CE Declaration of conformity**

We declare that the machine A483  
is in conformity with the following standard or  
standardised documents:  
98/37/EEC

FROMM Holding AG  
Hinterbergstrasse 26  
CH - 6330 Cham  
19.09 2003

R.Fromm  
Director



	<b>INDEX</b>	<b>PAGE</b>
<b>1</b>	<b>SAFETY INSTRUCTIONS</b>	<b>3</b>
<b>2</b>	<b>WARRANTY CONDITIONS AND LIABILITY</b>	<b>4</b>
<b>3</b>	<b>APPROPRIATE USE</b>	<b>4</b>
<b>4</b>	<b>CHART OF TYPES</b>	<b>4</b>
4.1	A483.0001 Semi-automatic . . . . .	4
4.2	A483.0002 Automatic . . . . .	4
<b>5</b>	<b>TECHNICAL DATA</b>	<b>5</b>
5.1	Tool size (without suspension bracket) . . . . .	5
5.2	Compressed air . . . . .	5
5.3	Air consumption . . . . .	5
5.4	Steel strap . . . . .	5
5.5	Seals . . . . .	5
5.6	Joint . . . . .	5
5.7	Sound information . . . . .	5
5.8	Vibration information . . . . .	5
<b>6</b>	<b>INSTALLATION</b>	<b>6</b>
<b>7</b>	<b>OPERATING CONTROLS</b>	<b>7</b>
<b>8</b>	<b>OPERATION</b>	<b>7</b>
8.1	Feeding the strapping . . . . .	7
8.2	Introducing the tool . . . . .	7
8.3	Tensioning the strapping . . . . .	8
8.4	Sealing the strapping . . . . .	8
8.5	Releasing the tool . . . . .	8
8.6	Tension regulation . . . . .	8
<b>9</b>	<b>MAINTENANCE</b>	<b>9</b>
9.1	Air-unit . . . . .	9
9.2	Cleaning . . . . .	9
9.3	Lubrication . . . . .	9
<b>10</b>	<b>JOINT CONTROL</b>	<b>9</b>
<b>11</b>	<b>EXCHANGE OF WEARING PARTS</b>	<b>10</b>
11.1	Exchange of feed wheel and slide plate . . . . .	10
11.2	Exchange of cutting jaws, notching knives and cutter . . . . .	11
11.3	Exchange of tension body / strap stop . . . . .	11
<b>12</b>	<b>SPARE PARTS LIST 13.4761.01</b>	<b>12</b>

# 1 SAFETY INSTRUCTIONS

Read these instructions carefully. Failure to follow these instructions can result in severe personal injury.

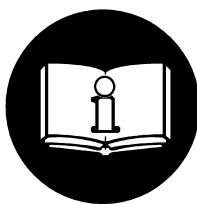

## Eye injury hazard

Failure to wear safety glasses with side shields can result in severe eye injury or blindness. Always wear safety glasses with side shields which conform to ANSI Standard Z87.1.



## Operation

Tool must not be used by persons not properly trained in their use. Before tensioning strap, read and understand the tool operating instructions. Failure to follow the operating instructions or improper load positioning could result in strap breakage.

Become familiar with your tool and keep fingers away from areas that can pinch or cut.

## Joints

You are fully responsible to review the joints made by your tool. Become familiar with the seal control and seal adjustment described in this operation manual. Misformed joints may not secure the load and could cause serious injury. Never handle or ship any load with improperly formed joints.

## Dispensing strap

Only dispense strap from a dispenser specifically designed for strap.

Tuck strap end back into dispenser when not in use.

## Protective gloves

When handling strap, always wear protective gloves.



## Strap warnings

Never use strap as a means of pulling or lifting loads. Failure to follow these warnings can result in severe personal injury.

## Strap breakage hazard

Improper operation of the tool, excessive tensioning, using strap not recommended for this tool or sharp corners on the load can result in a sudden loss of strap tension or in strap breakage during tensioning, which could result in the following:

- A sudden loss of balance causing you to fall.
- Both tool and strap flying violently towards your face.

Note as follows:

- If the load corners are sharp, use edge protectors.
- Place the strap correctly around a properly positioned load.
- Positioning yourself in-line with the strap, during tensioning and sealing, can result in severe personal injury from flying strap or tool. When tensioning or sealing, position yourself to one side of the strap and keep all bystanders away.
- Use the correct strap quality, strap width, strap gauge and strap tensile strength recommended in this manual for your tool. Using strap not recommended for this tool can result in strap breakage during tensioning.

## Cutting tensioned strap

When cutting strapping, use the proper strapping cutter and keep other personnel and yourself at a safe distance from the strap. Always stand to side of the strap, away from the direction the loosened strap end will fly. Use only cutters designed for strap and never hammers, pliers, hacksaws, axes, etc.

## Fall hazard

Keep your working area tidy. Untidiness of your working area may cause a risk of injury. Maintaining improper footing and/or balance when operating the tool can cause you to fall. Before tensioning and especially in elevated areas, always establish good balance. Both feet should be securely placed on a flat, solid surface, especially when working in elevated areas. Do not use the tool when you are in an awkward position.

Pay attention to the rules and regulations for preventions of accident which are valid for the work place.

## Tool hazards

A well maintained tool is a safe tool!

Check tool regularly for broken or worn parts. Do not operate a tool with broken or worn parts.

Never modify any tool. Modification can result in severe bodily injury.

## 2 WARRANTY CONDITIONS AND LIABILITY

FROMM Holding AG warrants all its strapping tools and machine heads during a period of 90 days from the date of sale. The warranty includes all deficiencies clearly resulting from poor manufacturing or faulty materials. Damage claims as a result of production shutdowns and claims for damage to persons and to property resulting from warranty deficiencies cannot be asserted by the customer.

The warranty excludes:

- wearing parts,
- deficiencies resulting from improper installing, incorrect handling and maintaining the tool,
- deficiencies resulting from using the tool without or with defective security- and safety devices,
- disregard of directions in the operation manual,
- arbitrary modifications of the tool,
- deficient control of wearing parts,
- deficient repair works of the tool.
- Use of consumable products not recommended by FROMM Holding AG

We reserve the right to modify the product at any time in order to improve its quality.

## 3 APPROPRIATE USE

The tool model A483 has been designed to strap packages with steel strapping exclusively.

The warranty / liability excludes:

- non appropriate use of the tool,
- disregard of directions in the operation manual,
- disregard of control- and maintenance instructions.

## 4 CHART OF TYPES

### 4.1 A483.0001 Semi-automatic

Item-No.	Model	Strap width	Strap thickness	Strap - quality	Max. tension		Speed	
					N	lbs.	mm/s	inch/s
13.4710	A483/25/0.80-0.90/ULT/7.0	25 mm / 1"	0.8-0.9 mm / .031"-.035"	ULT	7000	1570	200	8.0
13.4730	A483/25/0.80-1.00/UNI/7.0	25 mm / 1"	0.8-1.0 mm / .031"-.040"	UNI	7000	1570	200	8.0
13.4750	A483/32/0.80-0.90/ULT/7.0	32 mm / 1 1/4"	0.8-0.9 mm / .031"- .035"	ULT	7000	1570	200	8.0
13.4760	A483/32/0.80-0.90/ULT/9.0	32 mm / 1 1/4"	0.8-0.9 mm / .031"- .035"	ULT	9000	2020	160	6.5
13.4770	A483/32/0.80-1.00/UNI/7.0	32 mm / 1 1/4"	0.8-1.0 mm / .031"- .040"	UNI	7000	1570	200	8.0
13.4780	A483/32/0.80-1.00/UNI/9.0	32 mm / 1 1/4"	0.8-1.0 mm / .031"- .040"	UNI	9000	2020	160	6.5

### 4.2 A483.0002 Automatic

Item-No.	Model	Strap width	Strap thickness	Strap - quality	Max. tension		Speed	
					N	lbs.	mm/s	inch/s
13.4711	A483/25/0.80-0.90/ULT/7.0/A	25 mm / 1"	0.8-0.9 mm / .031"-.035"	ULT	7000	1570	200	8.0
13.4731	A483/25/0.80-1.00/UNI/7.0/A	25 mm / 1"	0.8-1.0 mm / .031"-.040"	UNI	7000	1570	200	8.0
13.4751	A483/32/0.80-0.90/ULT/7.0/A	32 mm / 1 1/4"	0.8-0.9 mm / .031"- .035"	ULT	7000	1570	200	8.0
13.4761	A483/32/0.80-0.90/ULT/9.0/A	32 mm / 1 1/4"	0.8-0.9 mm / .031"- .035"	ULT	9000	2020	160	6.5
13.4771	A483/32/0.80-1.00/UNI/7.0/A	32 mm / 1 1/4"	0.8-1.0 mm / .031"- .040"	UNI	7000	1570	200	8.0
13.4781	A483/32/0.80-1.00/UNI/9.0/A	32 mm / 1 1/4"	0.8-1.0 mm / .031"- .040"	UNI	9000	2020	160	6.5

UNI = Uniflex (Regular Duty max. 850 N/mm<sup>2</sup> / 123'000 psi)

ULT = Ultraflex (High Tensile max. 1100 N/mm<sup>2</sup> / 160'000 psi)

## 5 TECHNICAL DATA

### 5.1 Tool size (without suspension bracket)

	Tool	Package
Length:	412 mm / 16.2"	435 mm / 17.1"
Width:	238 mm / 9.4"	265 mm / 10.4"
Height:	278 mm / 11"	355 mm / 13.9"
Weight:	18.0 kg / 39.7 lbs	4 kg / 8.8 lbs

### 5.2 Compressed air

Working pressure:	5.5 bar / 79.75 psi (for tools with 32x0.8 Ultraflex Steel strap)
Maximum air pressure:	6.0 bar / 87 psi

### 5.3 Air consumption

Tensioning:	~ 22 NI/sec. / 0.77 cu.ft./sec.
Sealing:	~ 10 NI/0.353 cu.ft./cycle

### 5.4 Steel strap

Width:	25 - 32 mm / 1 - 1 1/4" (see chart of types)
Thickness:	0.8-1.0 mm / .031 -.039" (see chart of types)
Quality:	The A483 model allows the use of all current steel straps ranging from 600 - 1100 N/mm <sup>2</sup> / 87 000 - 160 000 psi in tensile (see chart of types). Strap with less than 600 N/mm <sup>2</sup> / 87 000 psi in tensile is not suitable for the A483 tool.

### 5.5 Seals

Strap width	Seal
25 mm / 1"	25x0.9x45 mm / 1"x.035"x1 3/4", push-type with overlapping flanges
32 mm / 1 1/4"	32x0.9x45 mm / 1"x.035"x1 3/4", push-type with overlapping flanges

### 5.6 Joint

Joint strength: approx. 75% of the tensile strength of the steel strap  
 A double-notch (two pairs of cut notches) is made per cycle.

### 5.7 Sound information

The A-weighted equivalent continuous sound level at the work place of the machine operator is typical 81 dB (A).  
 This value was determined according to DIN 45 635 T3 (11.85).

### 5.8 Vibration information

The weighted effective value of the acceleration typically amounts to less than 2,5m/s<sup>2</sup>.  
 This value was determined according to DIN EN 28 662 T1 (01.93).

## 6 INSTALLATION

### Compressed air connection

The compressed air is connected to the hose angle N6.5624 using a coupling.

An air-unit consisting of a separator for water and dirt, a pressure regulator with a manometer and a lubricator should be installed within a range of 15 ft/5 meters.

The compressed air must be free from dirt, rust and moisture.

### Suspension of tool

It is possible to suspend the tool on a spring loaded balancer using various suspension brackets. The following four types of suspension brackets can basically be used for all three working positions; their difference is in the working comfort. If the tool is frequently changed to a second or a third working position the appropriate suspension bracket should be mounted. Please refer to the sketches.

#### A48.3401

Not suitable for frequent swivelling.

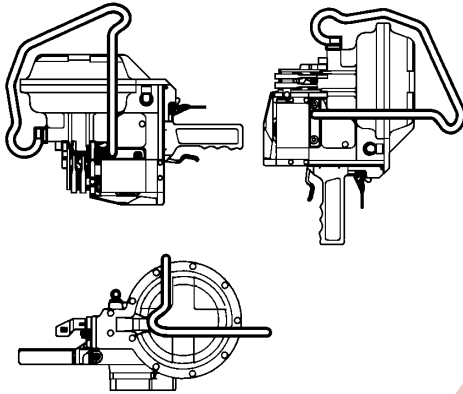

#### A48.3406

Suitable for frequent swivelling from „normal“ to „horizontal“.

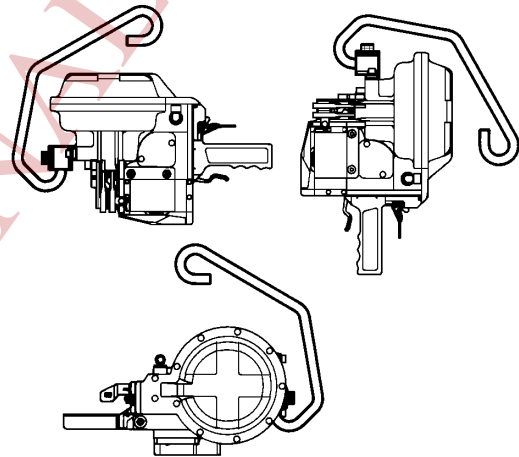

#### A48.3413

Suitable for frequent swivelling from „normal“ to „vertical“.

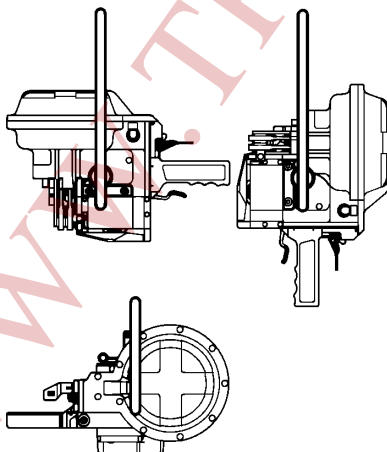

#### A48.3419

Suitable for frequent swivelling from „normal“ to „vertical“ and to „horizontal“.  
Incl. air supply

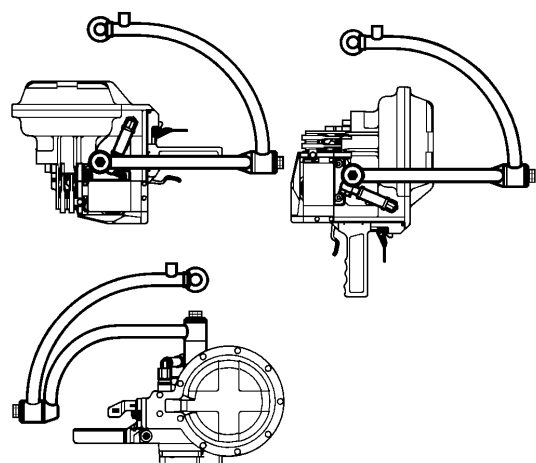

## 7 OPERATING CONTROLS

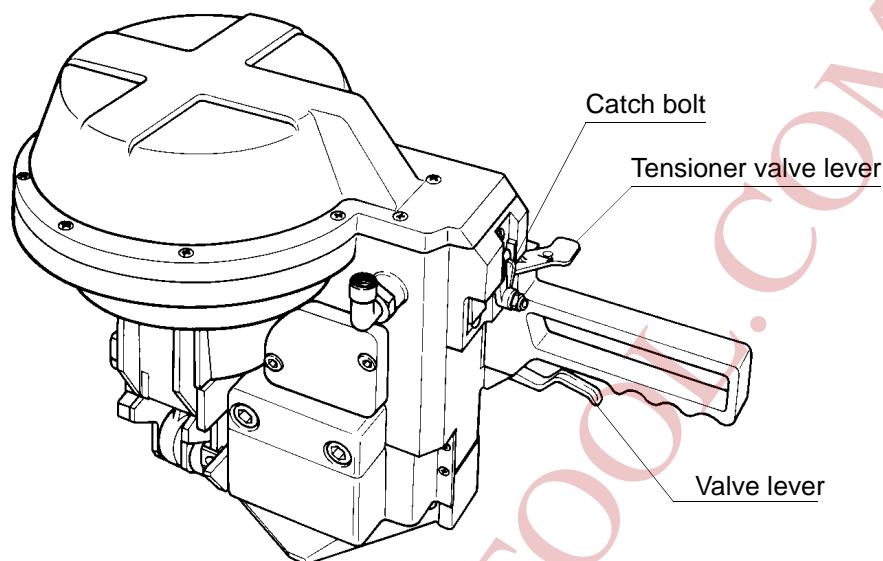

## 8 OPERATION



When handling strap, always wear protective gloves and safety glasses with side shields which conform to ANSI Standard Z87.1.



### 8.1 Feeding the strapping

The strap is fed through the seal, around the package to be strapped and again through the seal. The strap end is then bent. The operator then tensions the loose hoop manually making sure that the bent strap end is adjacent to the object to be strapped.

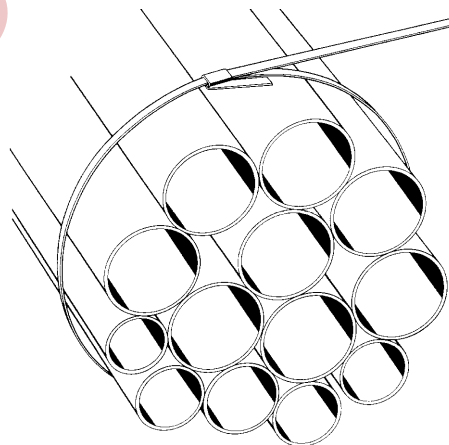

### 8.2 Introducing the tool

The upper strap is held with the left hand. With the index finger of the right hand the valve lever is activated (pulled) and the tool is introduced from right to left and from back to front resp. The valve lever is then released.

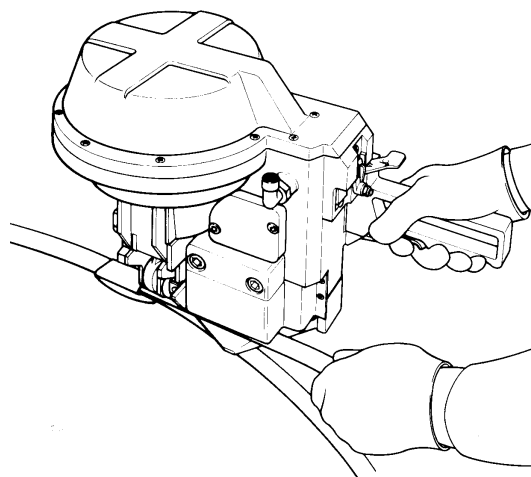

### 8.3 Tensioning the strapping

With the thumb of the right hand the tensioner valve lever is pressed so that it catches. The strap is tensioned until the air-motor stalls.  
If for any particular reason the tensioning cycle has to be interrupted the catch bolt has to be pressed to the left.

### 8.4 Sealing the strapping

After reaching the preadjusted strap tension the sealing cycle is started automatically and the strap is cut off at the same time.

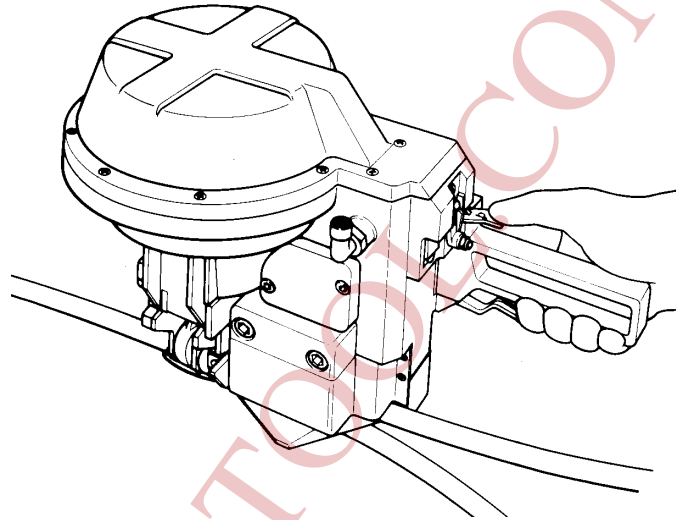

### 8.5 Releasing the tool

When the sealing process has been completed the tool can be released from the tensioned strap without any further action.  
By lifting the valve lever again, the strap end can be removed from the tool.

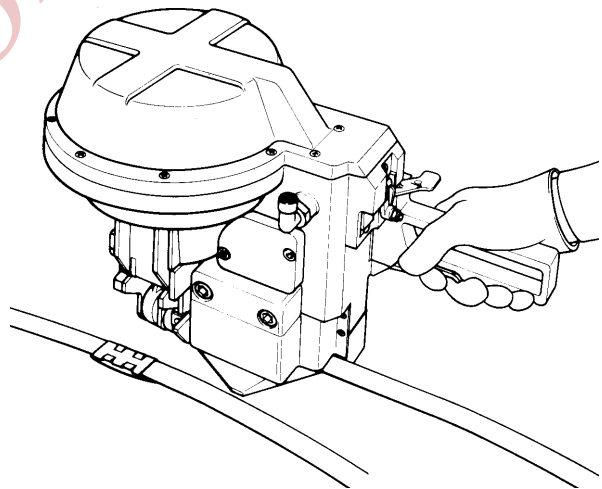

### 8.6 Tension regulation

Turning the set screw under the sealing valve lever in a clockwise direction results in a higher tension.  
The range of adjustment is within approx. 25 %.

If the sealing process is not started automatically when using a single button tool, the set screw has to be screwed out by turning in a anti-clockwise direction until the automatic system operates flawlessly.

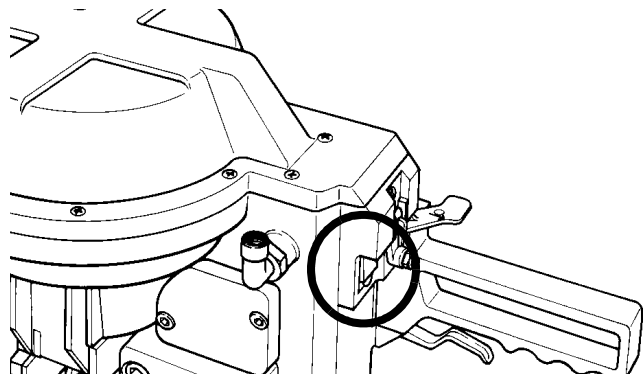



## 9 MAINTENANCE

Depending on the working conditions and the use of the tool the following maintenance has to be made periodically:

### 9.1 Air-unit

- Checking the air-pressure daily (never exceed 87 psi / 6.0 bar).
- Checking the oil-level daily.
- Draining the separator daily (unless automatic).
- Cleaning the filter following the instructions of the manufacturer of the air-unit

### Oil for the air unit

HL or CL ISO-VG 10

### 9.2 Cleaning

If impact of dirt and dust is considerable and if painted straps are used the feed wheel must be cleaned regularly. Normally it is sufficient to blow it out by the use of an air gun.

### 9.3 Lubrication

The gears are filled with MOLYKOTE BR2 PLUS. Use the same type of grease after repairs. When being exchanged, all valve parts and other movable parts have to be lubricated with grease of type ESSO BEACON 2 or with any equivalent product. The diaphragm must always be rubbed in with TALCUM before being installed.

## 10 JOINT CONTROL

A regular control of the joint is necessary. The joint can be checked visually and the person controlling can easily judge the quality of the joint. Following illustration shows a proper joint:

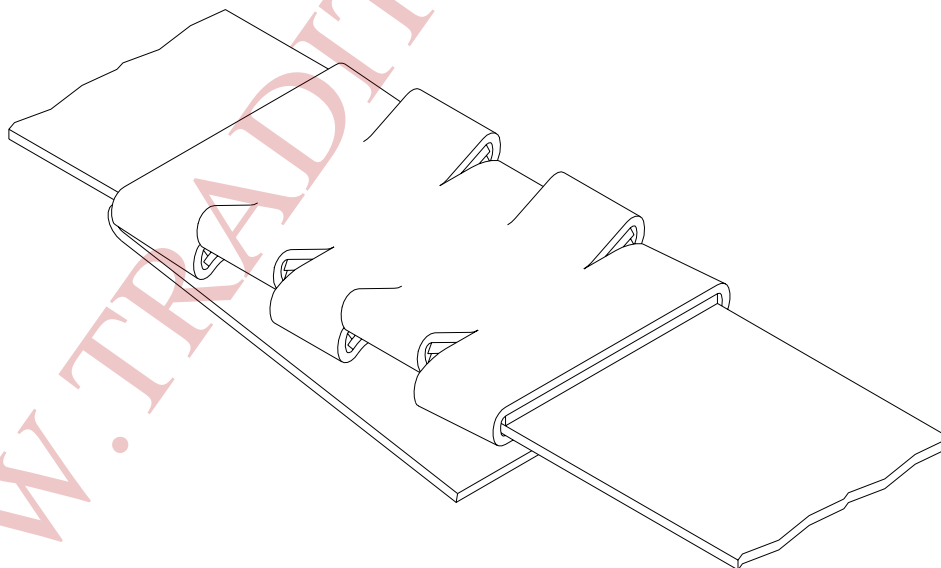

Sharp edged or misformed joints which do not appear as shown have to be taken away from the load immediately. The tensile strength of these joints is insufficient and they could cause serious injury. Having faulty joints proceed as follows:

- Checking the sealing cycle for improper use.(see 8. OPERATION)
- Having faulty joints in spite of proper use inspect the tool for worn or damaged parts. In case of wearing out or damaging replace tool parts as needed.

## 11 EXCHANGE OF WEARING PARTS

### 11.1 Exchange of feed wheel and slide plate

- Unscrew guard plate (4 recessed countersunk head screws N1.1808).
- Unscrew end plate (1 socket head cap screw N1.1169).
- Remove front distance ring and O-ring.
- Exchange feed wheel (please check correct position; inner toothing has to face towards end plate).
- To exchange the slide plate the holder has to be removed in addition (1 recessed countersunk head screw N1.1807).
- Reassemble in opposite order!

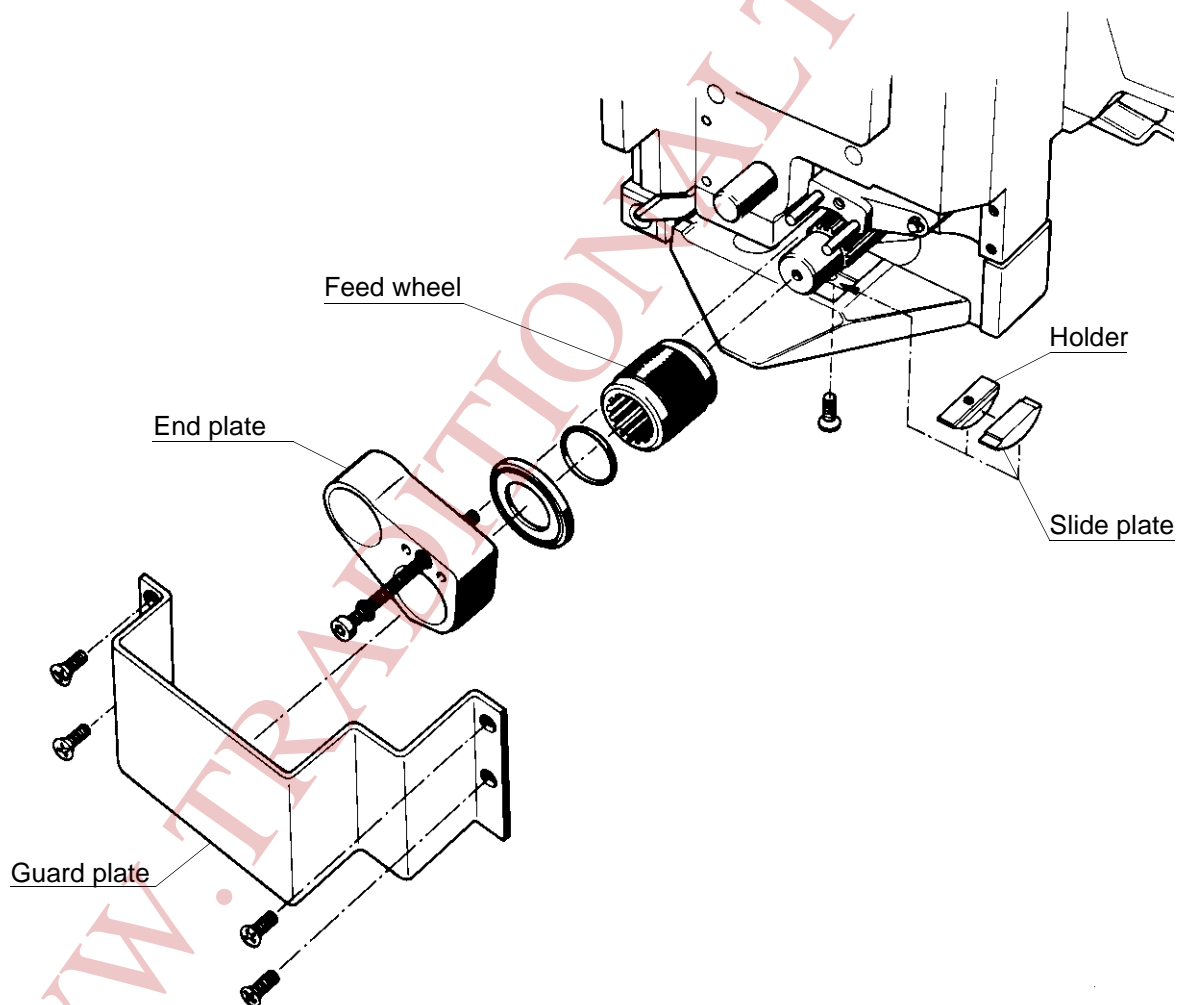

## 11.2 Exchange of cutting jaws, notching knives and cutter

- Unscrew cylinder cover A48.3111 (11 recessed countersunk head screws N1.1815).
- Remove diaphragm A48.3109.
- Unscrew piston plate A48.3107 (1 socket head cap screw N1.2114), push piston plate against the pressure springs at the same time).
- Remove disc and pressure springs.
- Unscrew cover plate A48.3105 (2 socket head cap screws N1.1108).
- Unscrew both cutting jaw guides A48.3106 (1 each recessed countersunk screw N1.1813).
- Remove cutting jaw assembly downwards in a diagonal position.
- Exchange cutter.
- In order to be able to exchange the notching knives and the cutting jaws one side plate of the cutting jaw assembly has to be unscrewed too (1 recessed countersunk head screw N1.2108 as well as 2 socket head cap screws A48.2132).
- Reassemble in opposite order!

**When reassembling make sure that:**

**The screws N1.1108 on the cover plate are tightened with 83 Nm.**

**The piston rod must be assembled meeting the groove of the piston plate.**

**All screws screwed in steel are secured with Loctite 222.**

## 11.3 Exchange of tension body / strap stop

- Slightly loosen cover plate A48.3105 (2 socket head cap screws N1.1108).
- Unscrew tension body (2 screws N1.1174) and pull it out towards the bottom.
- Remove and exchange strap stop by pulling out the 4 mm cylinder bolt from the tension body.
- Exchange tension body. Release 2 cylinder bolts, pressure spring, holder and slide plate.
- Reassemble in opposite order!

**When reassembling make sure that you:**

**The screws N1.1174 on the tension body are tightened with 90 Nm.**

**The screws N1.1108 on the cover plate are tightened with 83 Nm.**

**All screws screwed in steel are secured with Loctite 222.**

**12 SPARE PARTS LIST 13.4761.01**

13.4761.01	A483/32/0.80-0.90/ULT/9.0/A		A483.0002.01		27/07/98
Item-No.		Pcs.	Description	Dimension	Field
[A38.0132]		1	MOTOR CELL	EXC. 3,0	A19
A38.1148		1	SHAFT		C27
A38.1207	->[A48.0206]	1	TENSIONER VALVE SHELL		A17
A38.1209	->[A48.0206]	1	VALVE BOLT		B17
A38.1215	->[A48.0208]	1	GUIDE RING		C21
A38.1216	->[A48.0208]	5	SUSTAINING RING		C21+
A38.1217	->[A48.0208]	1	GUIDE RING		D21
A38.1218	->[A48.0208]	1	VALVE PISTON		C22
A38.1219	->[A48.0208]	1	BRIDGE		B21
A38.1220	->[A48.0208]	1	VALVE LEVER		C22
A38.1351	* ->[A38.0132]	8	VANE		B20
A38.1352	->[A38.0132]	1	END PLATE		A19
A38.1374	->[A38.0132]	16	FELT		B20+
A38.1376	->[A38.0132]	1	ROTOR		B20
A38.1377	->[A38.0132]	1	COUPLING		A19
A38.1378	->[A38.0132]	1	DOWEL		A19
A38.2301	->[A38.0132]	1	END PLATE		B19
A38.2302	->[A38.0132]	1	JACKET		A19
A38.2308	->[A48.0207]	1	TENSION SHAFT		B29
A38.2310	*	1	TENSIONING WHEEL		C27
A38.2311		1	SPACER RING		D26
A38.2317		1	HOLDER		C10
A38.2318		1	SPACER RING		C27
A38.2319	->[A48.0208]	1	PINION		B23
A38.2320	->[A48.0208]	1	INTERMEDIATE WHEEL	1-2	B22
A41.2120	->[A48.0202]	1	ROD BAR BOLT		D10
A46.2117	->[A48.0202]	2	JAW PIN		C2
A46.2118	->[A48.0202]	4	FRONT TOGGLE LINK		A3
A46.2132	->[A48.0208]	1	LEVER SHAFT		C23
A46.2145	->[A48.0202]	4	LEVER BOLT		A3+
[A48.0202]		1	JAW ASSEMBLY	32/0,8-0,9	A4
[A48.0206]		1	CYLINDER BOTTOM		A13
[A48.0207]		1	INTERMEDIATE GEAR		A28
[A48.0208]		1	GEAR	1 60.8	A24
A48.1237	->[A48.0206]	1	SIEVE		B11
A48.2113	->[A48.0202]	2	SPACER BUSH		B4
A48.2120	*	1	CUTTER JACK		D6
A48.2132	->[A48.0202]	4	SCREW		A2+
A48.3102		1	CONNECTION PLATE		C6
A48.3104	*	1	CUTTER	32 MM	C5
A48.3105		1	COVER PLATE		A1
A48.3106		2	TONG GUIDE		D5+
A48.3107		1	PISTON PLATE		B8
A48.3108		1	DISK		B8
A48.3109		1	DIAPHRAGM		A8
A48.3110		1	SEAL PLATE		B11
A48.3111		1	CYLINDER COVER		A8
A48.3113	* ->[A48.0202]	4	CUTTING JAW	32X0.8-0.9	B2+
A48.3116	* ->[A48.0202]	4	NOTCHING KNIFE	32 MM	C2+
A48.3117	->[A48.0202]	1	PISTON ROD		D9
A48.3119	->[A48.0202]	1	DISTANCE SUPPORT		C3
A48.3121	->[A48.0202]	1	SIDE PLATE		B5

[ ] = Group

\* = Wearing parts

13.4761.01	A483/32/0.80-0.90/ULT/9.0/A		A483.0002.01			27/07/98
Item-No.		Pcs.	Description	Dimension	Field	
A48.3123	->[A48.0202]	1	SIDE PLATE			B1
[A48.3124]	->[A48.0206]	1	CYLINDER BOTTOM			B10
A48.3127	->[A48.0206]	1	VALVE STEM			B15
A48.3128	->[A48.0206]	1	EXHAUST RING			B15
A48.3129	->[A48.0206]	1	SUSTAINING RING			A14
A48.3130	->[A48.0206]	1	CYLINDER SLEEVE			B16
A48.3131	->[A48.0206]	1	END RING			B16
A48.3132	->[A48.0206]	1	LEVER BODY			C18
A48.3133	->[A48.0206]	1	LEVER SHAFT			C18
A48.3134	->[A48.0206]	1	TENSIONER VALVE LEVER			D18
A48.3136	->[A48.0206]	1	CATCH SHAFT			C16
A48.3137	->[A48.0206]	1	CATCH LEVER			C18
A48.3138	->[A48.0206]	1	PISTON ROD			B26
A48.3139	->[A48.0206]	1	SEALING PLUG			B26
A48.3140		1	FORK			C27
A48.3141		1	GIB			C9
A48.3142	->[A48.0206]	1	PISTON			B15
A48.3147	->[A48.0206]	1	SEALING VALVE LEVER			D17
A48.3148	->[A48.0206]	1	COVER DISK			B17
A48.3151	->[A48.0206]	1	VALVE PISTON			C15
A48.3152	->[A48.0206]	1	VALVE CYLINDER			C15
A48.3153	->[A48.0206]	1	VALVE RING			C15
A48.3154	->[A48.0206]	1	SUSTAINING RING			C16
A48.3155	->[A48.0206]	1	TAPPED RING			C16
A48.3156	->[A48.0206]	1	ADJUSTING SCREW			C17
A48.3157		1	JAW GUIDE			B11
A48.3158		1	JAW GUIDE			C10
A48.3201		1	PIVOT PIN			C26
A48.3202		1	CAM ARM			C26
A48.3203		1	FORK BOLT			D26
A48.3204	->[A48.3227]	1	END COVER			C25
A48.3205		1	GUARD-PLATE			D9
A48.3206		1	COUPLING			B30
A48.3207		1	SEAL PLATE			C11
A48.3208		1	MOTOR COVER			C19
A48.3209	*	1	SLIDE JAW			C11
A48.3211		1	STRAP STOP	32 MM		D10
A48.3213	*	1	TENSIONING BODY	32 MM		D11
A48.3214	->[A48.3225]	1	INTERMEDIATE GEAR BODY			C28
A48.3215	->[A48.3226]	1	INTERMEDIATE GEAR COVER			B30
A48.3216	->[A48.0207]	1	PINION			B29
[A48.3217]	->[A48.0208]	1	GEAR BODY			C23
A48.3218	->[A48.3217]	1	GEAR BODY			C22
[A48.3219]	->[A48.0208]	1	GEARING COVER			C24
A48.3220	->[A48.3219]	1	GEARING COVER			B24
A48.3221	->[A48.0208]	1	INTERMEDIATE WHEEL	2-3		B22
A48.3222	->[A48.0208]	1	SPUR WHEEL	3		C23
A48.3223	->[A48.0208]	1	LEVER BODY			D22
[A48.3225]	->[A48.0207]	1	INTERMEDIATE GEAR BODY			D28
[A48.3226]	->[A48.0207]	1	INTERMEDIATE GEAR COVER			C30
[A48.3227]		1	END COVER			B25
N1.1123		2	SCREW	M8 X 30		D8
N1.1169		1	SCREW	M5 X 60		C25
N1.1174		2	SCREW	M10 X 1 X 40		D11

[ ] = Group

\* = Wearing parts

13.4761.01	A483/32/0.80-0.90/ULT/9.0/A		A483.0002.01			27/07/98
Item-No.		Pcs.	Description		Dimension	Field
N1.1180		2	SCREW		M6 X 90	B19
N1.1198		2	SCREW		M10 X 65	A1
N1.1807		1	SCREW		M5 X 12	D10
N1.1808		4	SCREW		M4 X 10	D8
N1.1811		3	SCREW		M6 X 40	B21+
N1.1813		2	SCREW		M5 X 16	C6+
N1.1814	->[A48.0206]	2	SCREW		M5 X 25	C18
N1.1814	->[A48.0207]	4	SCREW		M5 X 25	B30+
N1.1814	->[A48.0208]	2	SCREW		M5 X 25	A24
N1.1815		11	SCREW		M6 X 25	A8
N1.1817	->[A48.0208]	4	SCREW		M5 X 40	B24
N1.2108	->[A48.0202]	2	SOCKET COUNTERSUNK HEAD SCREW		M6 X 16	B1+
N1.2114		1	SOCKET COUNTERSUNK HEAD SCREW		M10 X 40	B8
N1.2212	->[A48.0208]	3	SOCKET COUNTERSUNK HEAD SCREW		M4 X 25	D22
N1.5301	->[A48.0206]	1	RETAINING NUT		M6	A14
N1.5302	->[A48.0206]	1	RETAINING NUT		M5	C18
N1.5608	->[A48.0206]	1	SLOTTED ROUND NUT		M8 X 1	B28
N1.6103	->[A48.0206]	1	WASHER		5.3 X 9.5 X 1	C18
N1.6114	->[A48.0206]	1	WASHER		6,4 X 12,5 X 1,6	B15
N1.6201		2	SPRING LOCK WASHER		M10	A1
N1.6206		2	SPRING LOCK WASHER		M8	C8
N1.6207		1	SPRING LOCK WASHER		M5	C25
N1.6220		2	SPRING LOCK WASHER		M6	B19
N1.6502		2	SAFETY WASHER		M10	D10
N2.1125		4	SECURITY RING		E3.2	C27+
N2.1219	->[A48.0206]	1	SECURITY RING		I34	B26
N2.1701	->[A48.0206]	1	SECURITY RING		17 MM	B28
N2.2109		2	PARALLEL PIN		8 M6 X 30	D11
N2.2125		1	PARALLEL PIN		4 M6 X 20	C9
N2.2155		2	PARALLEL PIN		5H6 X 70	C29
N2.2164	->[A48.0202]	1	PARALLEL PIN		6 M6 X 40	C4
N2.2172	->[A48.0207]	2	PARALLEL PIN		5M6 X 30	B29+
N2.2174	->[A48.0208]	2	PARALLEL PIN		6M6 X 60	B23
N2.2175		2	PARALLEL PIN		6M6 X 22	C5+
N2.2175	->[A48.0208]	1	PARALLEL PIN		6M6 X 22	B23
N2.2413	->[A38.0132]	1	DOWEL PIN		4 X 20 MM	A20
N2.2445	->[A38.0132]	1	DOWEL PIN		2,5 X 6 MM	B19
N2.3208	->[A48.0206]	1	WOODRUFF KEY		2 X 2,6 X 6,76	C17
N2.4407	->[A48.0208]	4	RIVET		2 X 3	B22
N2.4902		4	HAMMER HEAD BOLT		1,85 X 4,76	A9+
N2.5160	->[A48.0208]	1	PRESSURE SPRING		1 X 12 X 26	B21
N2.5161	->[A48.0206]	1	PRESSURE SPRING		1 X 12 X 20	A16
N2.5176		1	PRESSURE SPRING		0.6 X 5.5 X 31	C10
N2.5201		1	PRESSURE SPRING		4.5X74.5X195	A11
N2.5202		1	PRESSURE SPRING		5X98X220	C8
N2.5206	->[A48.0206]	1	PRESSURE SPRING		0,8 X 5,8 X 21	C16
N2.5609		2	CUP SPRING		45X22.5X1.75	B20
N2.5815	->[A48.0206]	1	TORSION SPRING			C18
N3.1102	->[A48.3225]	1	BALL BEARING			B28
N3.1109	->[A48.3217]	1	BALL BEARING			B22
N3.1109	->[A48.3219]	1	BALL BEARING			B23
N3.1123	->[A38.0132]	1	BALL BEARING			A20
N3.1133	->[A38.0132]	1	BALL BEARING			B19
N3.1144	->[A48.3217]	1	BALL BEARING			B22

[ ] = Group

\* = Wearing parts

13.4761.01	A483/32/0.80-0.90/ULT/9.0/A		A483.0002.01		27/07/98
Item-No.		Pcs.	Description	Dimension	Field
N3.1144	->[A48.3219]	1	BALL BEARING		B23
N3.1144	->[A48.3226]	1	BALL BEARING		B29
N3.1703	->[A48.0206]	1	BALL	5 MM.	C16
N3.1706	->[A48.0206]	1	BALL	15 MM	A16
N3.2322	->[A48.3217]	1	NEEDLE CASE		B20
N3.2322	->[A48.3219]	1	NEEDLE CASE		B24
N3.2323	->[A48.3217]	1	NEEDLE CASE		C20
N3.2323	->[A48.3219]	1	NEEDLE CASE		B24
N3.3130	->[A48.3226]	1	HEADED PRESS FIT BUSH		C29
N3.3140	->[A48.3225]	1	HEADED PRESS FIT BUSH		C28
N3.3141	->[A48.3227]	1	HEADED PRESS FIT BUSH		D26
N4.9138		1	LABEL	<<A483>>	C9
N4.9159		1	LABEL	<<CE>>	A9
N41.9128		1	ADHESIVE LABEL		A8
N41.9129		1	ADHESIVE LABEL		A8
N6.3207	->[A48.0208]	1	JOINT		B21
[N6.3405]	->[A48.0206]	1	PISTON PLATE		B28
N6.3504	->[N6.3405]	1	INNER PACKING	8.3X12.1X4	B28
N6.3509	->[N6.3405]	1	EXTERNAL PACKING RING	32	B28
N6.5133	->[A48.0206]	1	REDUCING COUPLING		A11
N6.5624	->[A48.0206]	1	ANGLE		A11
N6.6113	->[A48.0206]	1	PACKING RING	10 X 16 X 4.5	B28
N6.6117	->[A48.0208]	5	SEAL	6 X 13 X 2.3	C21+
N6.6120	->[A48.0206]	1	SEAL	16 X 9 X 2.3	C14
N6.6121	->[A48.0206]	1	SEAL	8 X 15 X 2.3	B17
N6.6122	->[A48.0206]	1	SEAL	20 X 13 X 2.3	B16
N6.6146	->[A48.0206]	1	SEAL	15 X 22 X 2.3	B16
N6.6147	->[A48.0206]	2	SEAL	10 X 17 X 2.3	C15+
N6.6148	->[A48.0206]	1	SEAL	18 X 25 X 4.5	B14
N6.6202		1	O-RING	25 X 2,5	C27
N6.6204	->[A48.0206]	5	O-RING	18 X 2	A16+
N6.6210	->[A48.0206]	1	O-RING	30 X 2	B26
N6.6213		1	O-RING	20 X 2	D27
N6.6217	->[A48.0208]	7	O-RING	15 X 2	B21+
N6.6223		1	O-RING	50 X 2	A20
N6.6233	->[A48.0206]	1	O-RING	6 X 2	A20
N6.6235	->[A48.0206]	1	O-RING	12 X 2	B17
N6.6241	->[A38.0132]	2	O-RING	46 X 2	B19
N6.6255	->[A48.0206]	4	O-RING	21 X 2	A14+
N6.6255	->[A48.0207]	1	O-RING	21 X 2	B29
N6.6803	->[A48.3217]	1	PACKING RING	10 X 19 X 9.8	B20
N7.1106	->[A48.3225]	1	BUSH		C27
N7.1106	->[A48.3227]	1	BUSH		D26
N7.1204	->[A48.3227]	2	SEALING DISK		D25
N7.1205	->[A48.3226]	1	SEALING DISK		C30

[ ] = Group

\* = Wearing parts

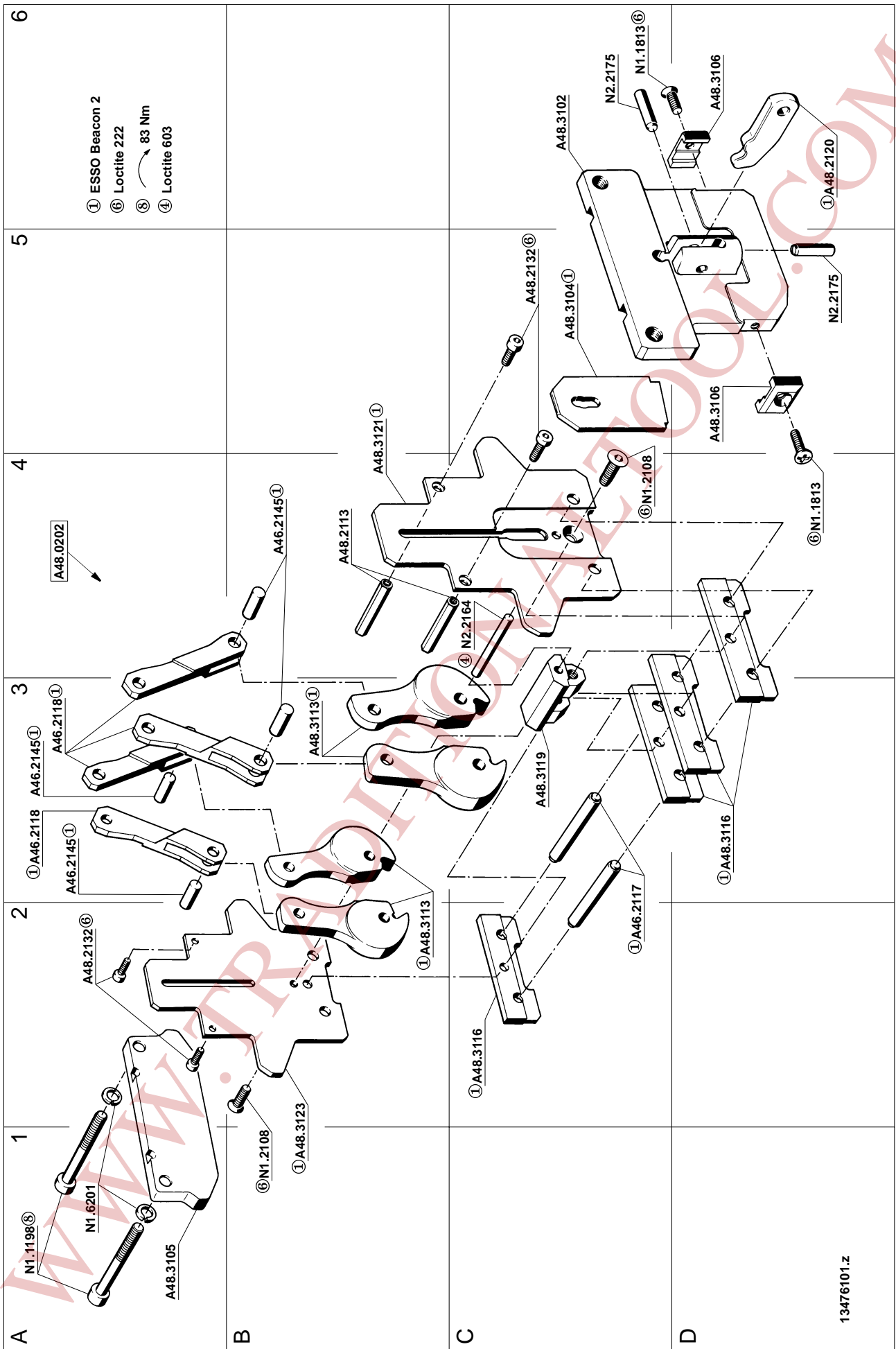

13476101.Z



