

**FROMM**  
OPERATION MANUAL / SPARE PARTS LIST  
**PNEUMATIC STEEL STRAPPING TOOL**  
**MODEL A384.0001**  
13.6861.01

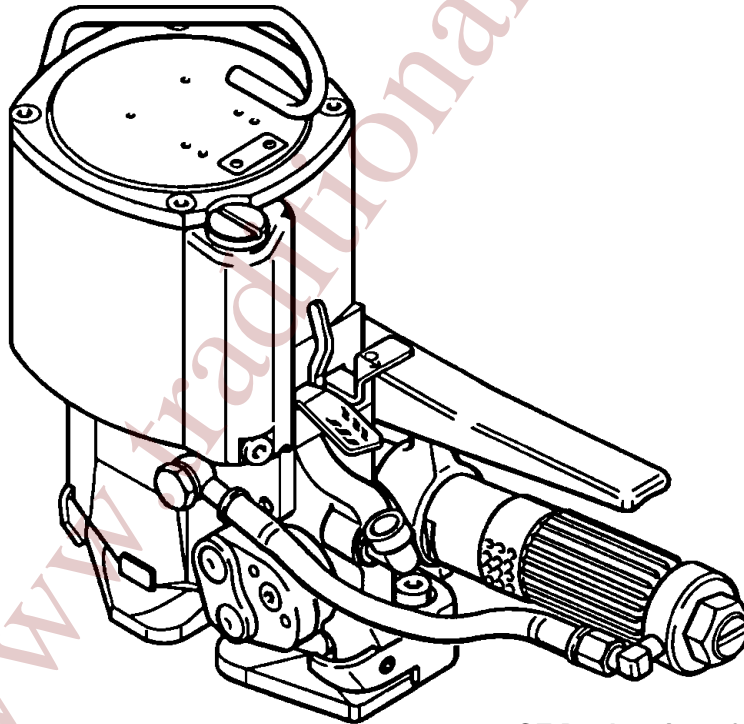

**CE Declaration of conformity**

We declare that the machine A384  
is in conformity with the following standard or  
standardised documents:  
98/37/EEC

FROMM Holding AG  
Hinterbergstrasse 26  
CH - 6330 Cham  
20.10.2004

  
R.Fromm  
Director



	<b>INDEX</b>	<b>PAGE</b>
<b>1</b>	<b>SAFETY INSTRUCTIONS</b>	<b>3</b>
<b>2</b>	<b>WARRANTY CONDITIONS AND LIABILITY</b>	<b>4</b>
<b>3</b>	<b>APPROPRIATE USE</b>	<b>4</b>
<b>4</b>	<b>CHART OF TYPES</b>	<b>4</b>
4.1	A384.0001 .....	4
4.2	A384.0002 .....	5
4.3	A384.0003 .....	5
4.4	A384.0004 .....	5
<b>5</b>	<b>TECHNICAL DATA</b>	<b>6</b>
5.1	Tool size (without suspension bracket) .....	6
5.2	Compressed air .....	6
5.3	Air consumption .....	6
5.4	Steel strap .....	6
5.5	Joint .....	6
5.6	Sound information .....	6
5.7	Vibration information .....	6
<b>6</b>	<b>INSTALLATION</b>	<b>7</b>
<b>7</b>	<b>OPERATING LEVERS</b>	<b>7</b>
<b>8</b>	<b>OPERATION</b>	<b>8</b>
8.1	Feeding the strap around the package .....	8
8.2	Loading the strap .....	8
8.3	Tensioning the strapping .....	8
8.4	Sealing the strapping .....	9
8.5	Removing the tool from the tensioned strap .....	9
8.6	Adjustment of the strap tension .....	9
8.7	Releasing the feed-wheel after faulty operation .....	9
<b>9</b>	<b>SPARE PARTS LIST 13.6861.01</b>	<b>12</b>
<b>10</b>	<b>SEAL CONTROL</b>	<b>16</b>
<b>11</b>	<b>SEAL ADJUSTMENT</b>	<b>17</b>
<b>12</b>	<b>MAINTENANCE</b>	<b>17</b>
12.1	Air unit .....	17
12.2	Cleaning .....	17
12.3	Lubrication .....	17
12.4	Oil level in the pressure intensifier .....	18
<b>13</b>	<b>EXCHANGE OF WEARING PARTS</b>	<b>19</b>
13.1	Exchange of the feed-wheel and the gripper .....	19
13.2	Exchange of punch, dies and cutter .....	20

# 1 SAFETY INSTRUCTIONS

Read these instructions carefully. Failure to follow these instructions can result in severe personal injury.

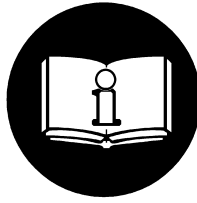

## Eye injury hazard

Failure to wear safety glasses with side shields can result in severe eye injury or blindness. Always wear safety glasses with side shields which conform to ANSI Standard Z87.1.



## Operation

Tool must not be used by persons not properly trained in their use. Before tensioning strap, read and understand the tool operating instructions. Failure to follow the operating instructions or improper load positioning could result in strap breakage. Become familiar with your tool and keep fingers away from areas that can pinch or cut.

## Joints

You are fully responsible to review the joints made by your tool. Become familiar with the seal control and seal adjustment described in this operation manual. Misformed joints may not secure the load and could cause serious injury. Never handle or ship any load with improperly formed joints.

## Dispensing strap

Only dispense strap from a dispenser specifically designed for strap. Tuck strap end back into dispenser when not in use.

## Protective gloves

When handling strap, always wear protective gloves.



## Strap warnings

Never use strap as a means of pulling or lifting loads. Failure to follow these warnings can result in severe personal injury.

## Strap breakage hazard

Improper operation of the tool, excessive tensioning, using strap not recommended for this tool or sharp corners on the load can result in a sudden loss of strap tension or in strap breakage during tensioning, which could result in the following:

- A sudden loss of balance causing you to fall.
- Both tool and strap flying violently towards your face.

Note as follows:

- If the load corners are sharp, use edge protectors.
- Place the strap correctly around a properly positioned load.
- Positioning yourself in-line with the strap, during tensioning and sealing, can result in severe personal injury from flying strap or tool. When tensioning or sealing, position yourself to one side of the strap and keep all bystanders away.
- Use the correct strap quality, strap width, strap gauge and strap tensile strength recommended in this manual for your tool. Using strap not recommended for this tool can result in strap breakage during tensioning.

## Cutting tensioned strap

When cutting strapping, use the proper strapping cutter and keep other personnel and yourself at a safe distance from the strap. Always stand to side of the strap, away from the direction the loosened strap end will fly. Use only cutters designed for strap and never hammers, pliers, hacksaws, axes, etc.

## Fall hazard

Keep your working area tidy. Untidiness of your working area may cause a risk of injury. Maintaining improper footing and/or balance when operating the tool can cause you to fall. Before tensioning and especially in elevated areas, always establish good balance. Both feet should be securely placed on a flat, solid surface, especially when working in elevated areas. Do not use the tool when you are in an awkward position.

Pay attention to the rules and regulations for preventions of accident which are valid for the work place.

## Tool hazards

A well maintained tool is a safe tool!

Check tool regularly for broken or worn parts. Do not operate a tool with broken or worn parts.

Never modify any tool. Modification can result in severe bodily injury.

## 2 WARRANTY CONDITIONS AND LIABILITY

FROMM Holding AG warrants all its strapping tools and machine heads during a period of 90 days from the date of sale. The warranty includes all deficiencies clearly resulting from poor manufacturing or faulty materials. Damage claims as a result of production shutdowns and claims for damage to persons and to property resulting from warranty deficiencies cannot be asserted by the customer.

The warranty excludes:

- wearing parts,
- deficiencies resulting from improper installing, incorrect handling and maintaining the tool,
- deficiencies resulting from using the tool without or with defective security- and safety devices,
- disregard of directions in the operation manual,
- arbitrary modifications of the tool,
- deficient control of wearing parts,
- deficient repair works of the tool.
- Use of consumable products not recommended by FROMM Holding AG

We reserve the right to modify the product at any time in order to improve its quality.

## 3 APPROPRIATE USE

The tool model A384 has been designed to strap packages with steel strapping exclusively.

The warranty / liability excludes:

- non appropriate use of the tool,
- disregard of directions in the operation manual,
- disregard of control- and maintenance instructions.

## 4 CHART OF TYPES

### 4.1 A384.0001

Item-No.	Model	Strap width	Strap thickness	Max. tension		Tensioning speed	
				N	lbs.	mm/s	inch/s
13.6831	A384/12.7/0.38-0.50/6.5	12.7mm / 1/2"	0.38-0.50mm / .015-.020"	6500	1460	60	2.3
<del>13.6833</del>	<del>A384/12.7/0.58-0.63/6.5</del>	<del>12.7mm / 1/2"</del>	<del>0.58-0.63mm / .023-.025"</del>	<del>6500</del>	<del>1460</del>	<del>60</del>	<del>2.3</del>
13.6841	A384/13/0.38-0.50/6.5	13.0 mm	0.38-0.50mm / .015-.020"	6500	1460	60	2.3
13.6843	A384/13/0.58-0.63/6.5	13.0 mm	0.58-0.63mm / .023-.025"	6500	1460	60	2.3
13.6851	A384/16/0.38-0.50/6.5	16.0 mm / 5/8"	0.38-0.50mm / .015-.020"	6500	1460	60	2.3
13.6853	A384/16/0.58-0.63/6.5	16.0 mm / 5/8"	0.58-0.63mm / .023-.025"	6500	1460	60	2.3
13.6861	A384/19/0.50-0.63/6.5	19.0 mm / 3/4"	0.50-0.63mm / .020-.025"	6500	1460	60	2.3
13.6871	A384/20/0.50-0.63/6.5	20.0 mm	0.50-0.63mm / .020-.025"	6500	1460	60	2.3

## 4.2 A384.0002

Item-No.	Model	Strap width	Strap thickness	Max. tension		Tensioning speed	
				N	lbs.	mm/s	inch/s
13.6835	A384/12.7/0.38-0.50/4.1	12.7mm / 1/2"	0.38-0.50mm / .015-.020"	4100	920	95	3.7
13.6837	A384/12.7/0.58-0.63/4.1	12.7mm / 1/2"	0.58-0.63mm / .023-.025"	4100	920	95	3.7
13.6845	A384/13/0.38-0.50/4.1	13.0 mm	0.38-0.50mm / .015-.020"	4100	920	95	3.7
13.6847	A384/13/0.58-0.63/4.1	13.0 mm	0.58-0.63mm / .023-.025"	4100	920	95	3.7
13.6855	A384/16/0.38-0.50/4.1	16.0 mm / 5/8"	0.38-0.50mm / .015-.020"	4100	920	95	3.7
13.6857	A384/16/0.58-0.63/4.1	16.0 mm / 5/8"	0.58-0.63mm / .023-.025"	4100	920	95	3.7
13.6863	A384/19/0.50-0.63/4.1	19.0 mm / 3/4"	0.50-0.63mm / .020-.025"	4100	920	95	3.7
13.6873	A384/20/0.50-0.63/4.1	20.0 mm	0.50-0.63mm / .020-.025"	4100	920	95	3.7

## 4.3 A384.0003

Item-No.	Model	Strap width	Strap thickness	Max. tension		Tensioning speed	
				N	lbs.	mm/s	inch/s
13.6810	A384/9.5/0.38-0.50/3.5	9.5mm / 3/8"	0.38-0.50mm / .015-.020"	3500	780	105	4.1
13.6820	A384/10/0.38-0.50/3.5	10.0 mm	0.38-0.50mm / .015-.020"	3500	780	105	4.1
13.6830	A384/12.7/0.38-0.50/3.5	12.7mm / 1/2"	0.38-0.50mm / .015-.020"	3500	780	105	4.1
13.6832	A384/12.7/0.58-0.63/3.5	12.7mm / 1/2"	0.58-0.63mm / .023-.025"	3500	780	105	4.1
13.6840	A384/13/0.38-0.50/3.5	13.0 mm	0.38-0.50mm / .015-.020"	3500	780	105	4.1
13.6842	A384/13/0.58-0.63/3.5	13.0 mm	0.58-0.63mm / .023-.025"	3500	780	105	4.1
13.6850	A384/16/0.38-0.50/3.5	16.0 mm / 5/8"	0.38-0.50mm / .015-.020"	3500	780	105	4.1
13.6852	A384/16/0.58-0.63/3.5	16.0 mm / 5/8"	0.58-0.63mm / .023-.025"	3500	780	105	4.1
13.6860	A384/19/0.50-0.63/3.5	19.0 mm / 3/4"	0.50-0.63mm / .020-.025"	3500	780	105	4.1
13.6870	A384/20/0.50-0.63/3.5	20.0 mm	0.50-0.63mm / .020-.025"	3500	780	105	4.1

## 4.4 A384.0004

Item-No.	Model	Strap width	Strap thickness	Max. tension		Tensioning speed	
				N	lbs.	mm/s	inch/s
13.6811	A384/9.5/0.38-0.50/2.2	9.5mm / 3/8"	0.38-0.50mm / .015-.020"	2200	495	165	6.5
13.6821	A384/10/0.38-0.50/2.2	10.0 mm	0.38-0.50mm / .015-.020"	2200	495	165	6.5
13.6834	A384/12.7/0.38-0.50/2.2	12.7mm / 1/2"	0.38-0.50mm / .015-.020"	2200	495	165	6.5
13.6836	A384/12.7/0.58-0.63/2.2	12.7mm / 1/2"	0.58-0.63mm / .023-.025"	2200	495	165	6.5
13.6844	A384/13/0.38-0.50/2.2	13.0 mm	0.38-0.50mm / .015-.020"	2200	495	165	6.5
13.6846	A384/13/0.58-0.63/2.2	13.0 mm	0.58-0.63mm / .023-.025"	2200	495	165	6.5
13.6854	A384/16/0.38-0.50/2.2	16.0 mm / 5/8"	0.38-0.50mm / .015-.020"	2200	495	165	6.5
13.6856	A384/16/0.58-0.63/2.2	16.0 mm / 5/8"	0.58-0.63mm / .023-.025"	2200	495	165	6.5
13.6862	A384/19/0.50-0.63/2.2	19.0 mm / 3/4"	0.50-0.63mm / .020-.025"	2200	495	165	6.5
13.6872	A384/20/0.50-0.63/2.2	20.0 mm	0.50-0.63mm / .020-.025"	2200	495	165	6.5

---

## 5 TECHNICAL DATA

### 5.1 Tool size (without suspension bracket)

	Tool:	Package:
Length:	322 mm / 12.7"	420 mm / 16.5"
Width:	146 mm / 5.8"	155 mm / 6.1"
Height:	242 mm / 9.5"	390 mm / 15.4"

### Weight

Without suspension bracket	10.0 kg / 22 lbs
With suspension bracket:	10.5 Kg / 23.2 lbs
Package:	1.4 kg / 3.1 lbs

### 5.2 Compressed air

Maximum air pressure:	6.0 bar / 87 psi
Air connection:	G 1/4" minimum (The minimum air passage diameter must not be smaller on fittings and couplings either).

### 5.3 Air consumption

Tensioning:	~ 8 NI/s / 0.28 cu.ft./s
Sealing:	~ 3.5 NI/cycle / 0.12 cu.ft./cycle

### 5.4 Steel strap

Width:	9.5 - 20.0 mm / 3/8" - 3/4" (see chart of types)
Thickness:	0.38-0.63 mm / .015 - .025"(see chart of types)
Quality:	The model A384 allows the use of all current steel straps with tensile strengths ranging from 700 - 1100 N/mm <sup>2</sup> (100 000 - 160 000 psi) Straps with a low breaking elongation are unsuitable.

### 5.5 Joint

Joint strength: approx. 80% of the tensile strength of the steel strap

### 5.6 Sound information

The A-weighted equivalent continuous sound level at the work place of the machine operator is typical 81 dB (A).

This value was determined according to DIN 45 635 T3 (11.85).

### 5.7 Vibration information

The weighted effective value of the acceleration typically amounts to less than 2,5m/s<sup>2</sup>.  
This value was determined according to DIN EN 28 662 T1 (01.93).

## 6 INSTALLATION

### Compressed air connection

The compressed air is to be connected to the tool preferably by a quick disconnect.

It is very important to clean the compressed air with air unit consisting of a separator for water and dirt, a pressure regulator with a manometer and a lubricator.

The maximum length of the air tube between air unit and tool has to be 5m/15 ft.

### Suspension of tool

It is possible to suspend the tool on a spring loaded balancer using the suspension bracket A38.3401 which is supplied with the tool. The suspension bracket has been designed in such a way, that the tool can be used for all three working positions.

Standard position

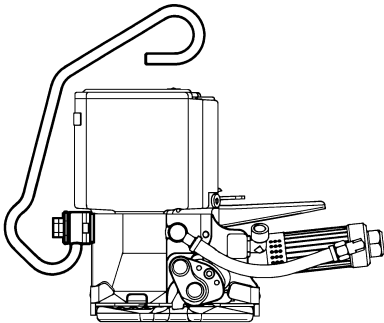

Vertical position

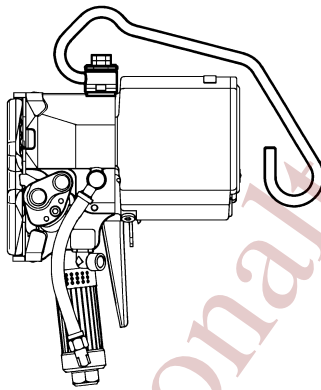

Horizontal position

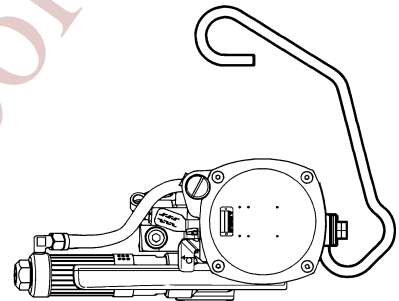

## 7 OPERATING LEVERS

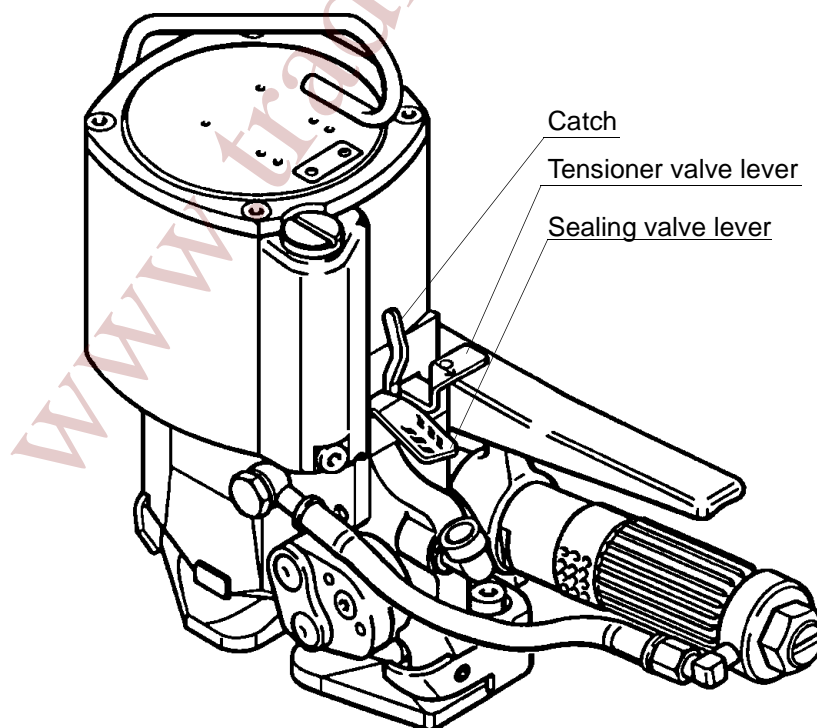

## 8 OPERATION



When handling strap, always wear protective gloves and safety glasses with side shields which conform to ANSI Standard Z87.1.



### 8.1 Feeding the strap around the package

The strapping is fed around the package as illustrated.

With the left hand the strap is held tightly and pulled firmly towards the operator with the right hand.

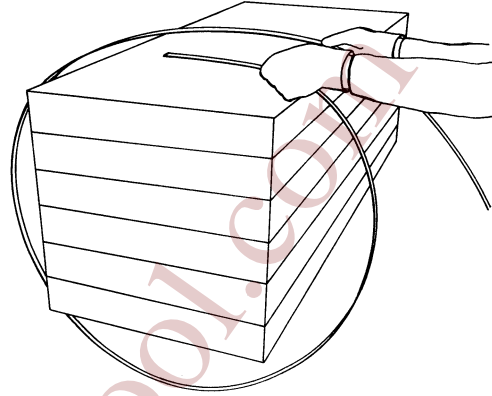

### 8.2 Loading the strap

Pull the air-motor towards the handle using the right hand. The left hand inserts the two straps lying precisely upon another into the tool until they hit the strap stops.

By releasing the air-motor the feed-wheel is lowered to the strap.

By pulling the strap at its rear end it can be pretensioned manually.

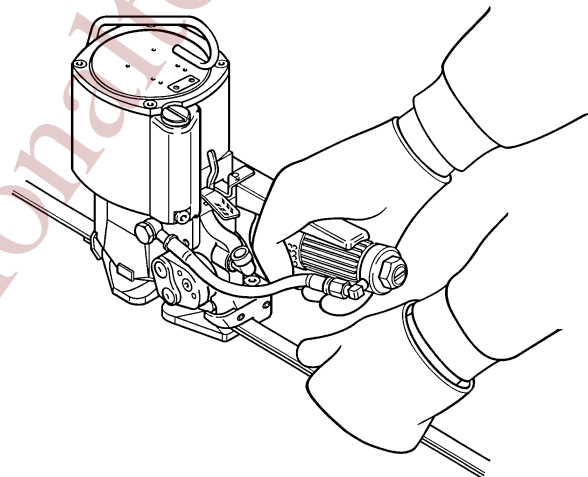

### 8.3 Tensioning the strapping

With the thumb of the right hand the tensioning valve lever is pressed down until the catch locks. Let the tool tension until the air-motor stalls.

If the tensioning cycle has to be interrupted (faulty strap, applying of corner protectors) push the catch to the left.

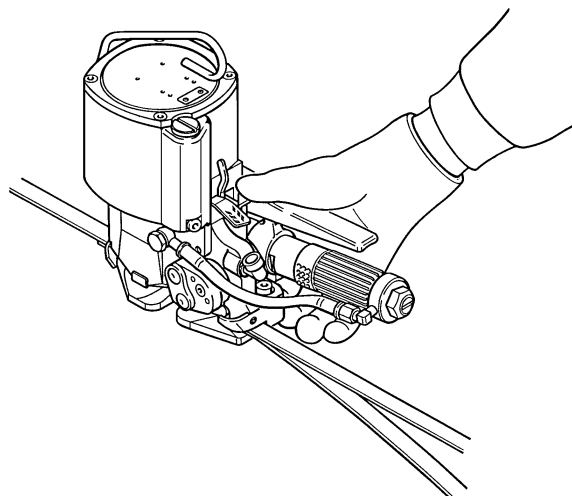



## 8.4 Sealing the strapping

With the thumb of the right hand the sealing valve lever is pressed down until the sealing cycle has been completed.

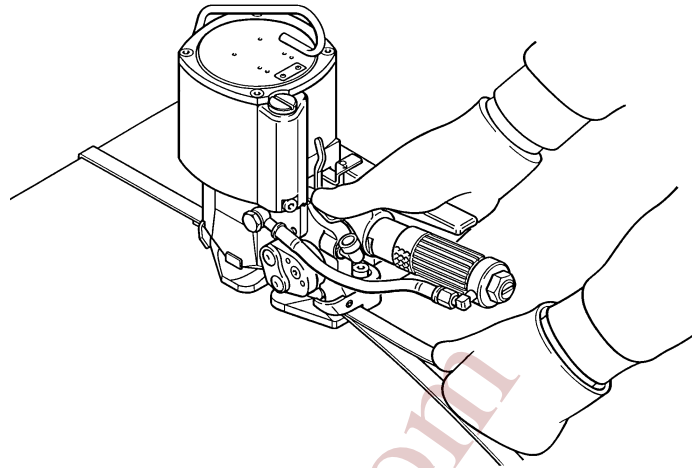

## 8.5 Removing the tool from the tensioned strap

The cut off strap end is held with the left hand. At the same time the air-motor is pulled to the handle using the right hand and the tool is pushed to the right.

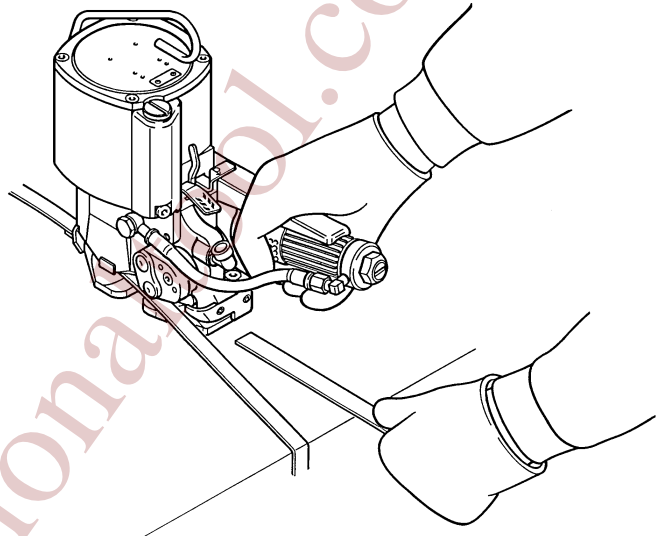

## 8.6 Adjustment of the strap tension

The strap tension may be adjusted by turning the set screw.

The range of adjustment is approx. 20%. Turning the set screw in a clockwise direction increases the strap tension.

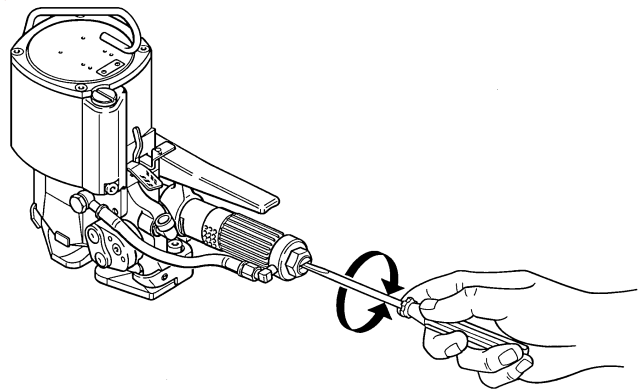

## 8.7 Releasing the feed-wheel after faulty operation

If, due to a faulty tool operation the feed-wheel jams onto the straps, so that it cannot be removed from the tool, the following action has to be taken: Remove the plug N6.3207. Turn the worm clockwise (using a screw-driver) until the jam is released. Screw in the plug.

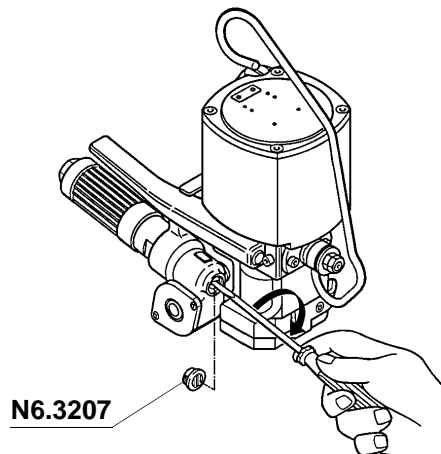

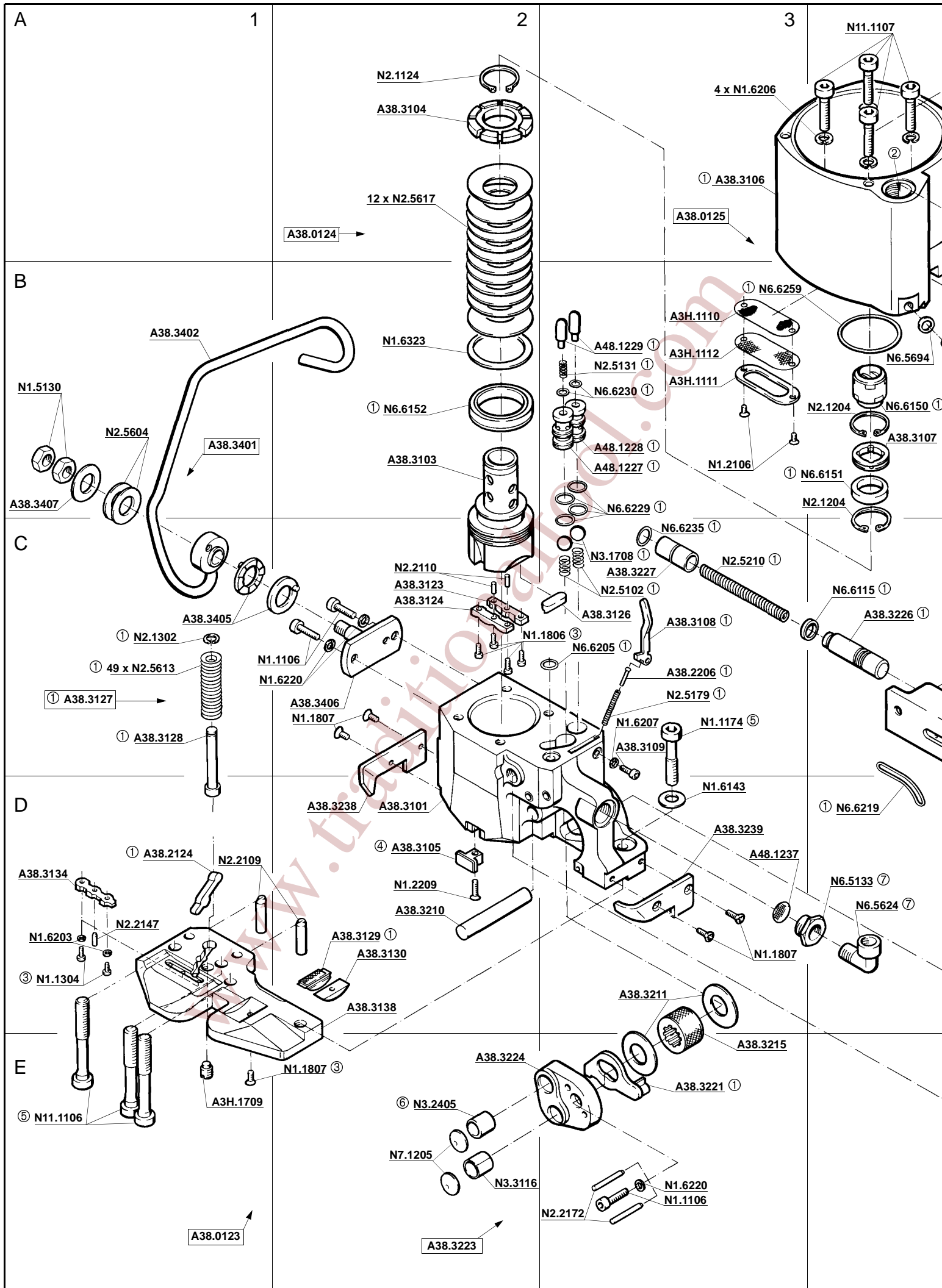

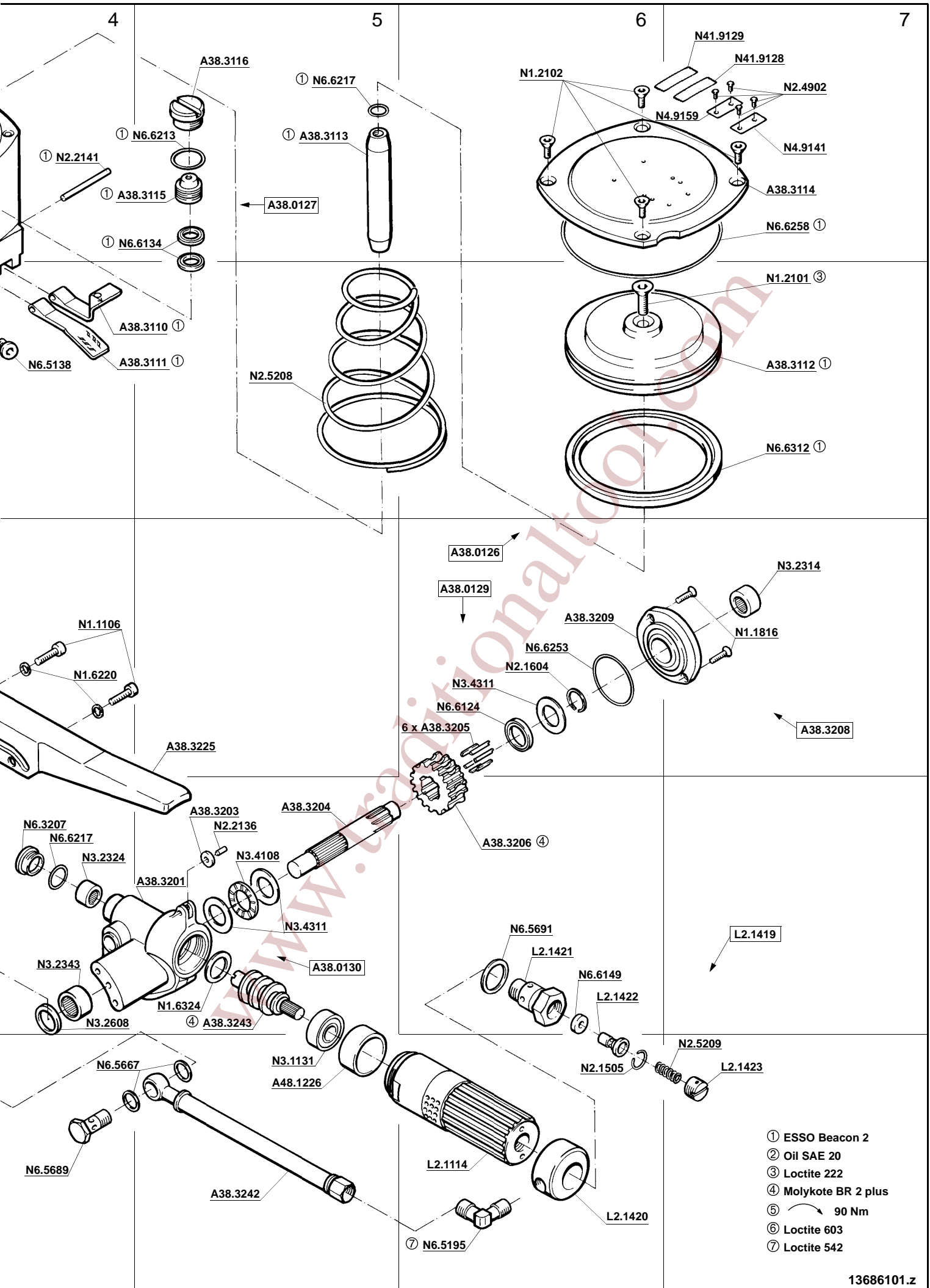

13686101.z

## 9 SPARE PARTS LIST 13.6861.01

13.6861.01	A384/19/0.50-0.63/6.5		A384.0001.01		04.10.99	
Item-No.		in group	Pcs.	Description	Dimension	Field
A3H.1110		A38.0123	1	FILTER NETTING		B3
A3H.1111		A38.0123	1	NETTING FRAME		B3
A3H.1112		A38.0123	1	PROTECTION NETTING		B3
A3H.1709			1	ADJUSTING SCREW		E1
[A38.0123]			1	SEALER		E1
[A38.0124]		A38.0123	1	DIE AND CUTTER SUPPORT		A2
[A38.0125]		A38.0123	1	SEALING CYLINDER		A3
[A38.0126]		A38.0123	1	PISTON PLATE		C6
[A38.0127]		A38.0123	1	COMPENSATOR PISTON		A5
[A38.0129]			1	TENSIONING UNIT	6,5KN	C6
[A38.0130]		A38.0129	1	GEAR BODY		D5
A38.2124			1	EJECTOR		D1
A38.2206		A38.0123	1	SPRING BUSHING		C3
[A38.3101]		A38.0123	1	SEALING HOUSING		D2
A38.3103		A38.0124	1	DIE AND CUTTER SUPPORT		B2
A38.3104		A38.0124	1	PRESSURE RING		A2
A38.3105		A38.0123	1	GUIDE KEY		D2
A38.3106		A38.0125	1	SEALING CYLINDER		A3
A38.3107		A38.0125	1	GUIDE RING		B4
A38.3108		A38.0123	1	CATCH		C3
A38.3109		A38.0123	1	SCREW		C3
A38.3110		A38.0123	1	TENSIONER VALVE LEVER		B5
A38.3111		A38.0123	1	SEALING VALVE LEVER		B5
A38.3112		A38.0126	1	PISTON PLATE		B7
A38.3113		A38.0123	1	PISTON ROD		A5
A38.3114		A38.0123	1	CYLINDER COVER		A7
A38.3115		A38.0127	1	COMPENSATOR PISTON		A5
A38.3116		A38.0123	1	SEALING SCREW		A5
A38.3123	*		1	DIE HALF		C2
A38.3124	*		1	DIE HALF		C2
A38.3126	*		1	CUTTER		C3
[A38.3127]			1	SPRING PACKAGE		C1
A38.3128		A38.3127	1	SPINDLE		C1
A38.3129	*		1	GRIPPER		D2
A38.3130			1	HOLDER		D2
A38.3134	*		1	PUNCH		D1
A38.3138			1	BASE PLATE		D2
[A38.3201]		A38.0130	1	GEAR BODY		D5
A38.3203		A38.0130	1	PRESS ROLLER		D5
A38.3204		A38.0129	1	TENSION SHAFT		D5
A38.3205	*	A38.0129	6	CATCH PAWL		C6
A38.3206		A38.0129	1	WORM WHEEL		D6
[A38.3208]		A38.0129	1	END COVER		C7
A38.3209		A38.3208	1	END COVER		C6
A38.3210			1	PIVOT PIN		D2
A38.3211			2	SPACER RING		D3
A38.3215	*		1	TENSIONING WHEEL		E3
A38.3221			1	STRAP GUIDE		E3
[A38.3223]			1	END COVER		E2
A38.3224		A38.3223	1	END COVER		E2
A38.3225			1	TANG		C5

[ ] = Group

\* = Wearing parts

13.6861.01	A384/19/0.50-0.63/6.5		A384.0001.01		04.10.99	
Item-No.		in group	Pcs.	Description	Dimension	Field
A38.3226			1	PISTON		C4
A38.3227			1	SPRING SOCKET		C3
A38.3238			1	STRAP STOP		D2
A38.3239			1	STRAP STOP		D3
[A38.3242]			1	HOSE		E5
A38.3243		A38.0129	1	WORM		D5
[A38.3401]			1	SUSPENSION BRACKET		B1
[A38.3402]		A38.3401	1	SUSPENSION BRACKET		B1
A38.3405		A38.3401	2	RATCHET DISK		C1
A38.3406		A38.3401	1	FLANGE SHAFT		C2
A38.3407		A38.3401	1	THRUST WASHER		B1
A48.1226		A38.0129	1	BEARING JACKET		E5
A48.1227		A38.0123	1	VALVE SHELL		B3
A48.1228		A38.0123	1	VALVE SHELL		B3
A48.1229		A38.0123	2	VALVE BOLT		B3
A48.1237		A38.0123	1	SIEVE		D3
[L2.1114]		A38.0129	1	AIR MOTOR		E6
L2.1201		L2.1114	1	EXHAUST RING		--
L2.1203		L2.1212	1	PLASTIC JACKET		--
[L2.1212]		L2.1114	1	HOUSING		--
L2.1301		L2.1114	1	END PLATE		--
L2.1302		L2.1114	1	PARALLEL PIN		--
L2.1303		L2.1114	1	CYLINDER		--
L2.1304	*	L2.1114	5	VANE		--
L2.1305		L2.1114	1	ROTOR		--
L2.1308		L2.1114	1	SILENCER		--
L2.1309		L2.1114	1	PLANET SHAFT		--
L2.1310		L2.1114	2	NEEDLE CAGE		--
L2.1311		L2.1114	2	GEAR WHEEL		--
L2.1312		L2.1114	2	SHAFT		--
L2.1313		L2.1114	1	BEARING RING		--
L2.1314		L2.1114	1	END PLATE		--
L2.1402		L2.1114	32	BEARING NEEDLE		--
L2.1403		L2.1114	2	GEAR WHEEL		--
L2.1404		L2.1114	2	SHAFT		--
L2.1405		L2.1114	1	BEARING RING		--
L2.1408		L2.1114	1	PLANETARY CAGE		--
L2.1410		L2.1114	1	TENSION SCREW		--
[L2.1419]		A38.0129	1	REGULATOR HEAD		D7
L2.1420		L2.1419	1	AIR INLET RING		E6
L2.1421		L2.1419	1	CONTROL HEAD		D6
L2.1422		L2.1419	1	VARIABLE PISTON		D6
L2.1423		L2.1419	1	CONTROL SCREW		E7
L2.1505		L2.1114	1	KEY		--
N11.1106			3	SCREW	M10 X 1 X 65	E1
N11.1107		A38.0123	4	SCREW	M8 X 35	A4
N1.1106		A38.3401	2	SCREW	M6 X 20	C2
N1.1106			3	SCREW	M6 X 20	C4+
N1.1174			1	SCREW	M10 X 1 X 40	C3
N1.1304			2	SCREW	M3 X 8	D1
N1.1806			4	SCREW	M4 X 10	C3
N1.1807			5	SCREW	M5 X 12	C2+
N1.1816		A38.0129	2	SCREW	M4 X 16	C7

[ ] = Group

\* = Wearing parts

13.6861.01	A384/19/0.50-0.63/6.5		A384.0001.01			04.10.99
Item-No.		in group	Pcs.	Description	Dimension	Field
N1.2101		A38.0123	1	COUNTERSUNK SCREW	M8 X 25	B7
N1.2102		A38.0123	4	COUNTERSUNK SCREW	M6 X 20	A6
N1.2106		A38.0123	2	COUNTERSUNK SCREW	M4 X 8	B3
N1.2209		A38.0123	1	COUNTERSUNK SCREW	M4 X 18	D2
N1.5130		A38.3401	2	HEXAGON NUT	0,5D M10	B1
N1.6143			1	DISK		D3
N1.6203			2	SPRING LOCK WASHER	M3	D1
N1.6206		A38.0123	4	SPRING LOCK WASHER	M8	A3
N1.6207		A38.0123	1	SPRING LOCK WASHER	M5	C3
N1.6220		A38.3401	2	SPRING LOCK WASHER	M6	C2
N1.6220			3	SPRING LOCK WASHER	M6	C4+
N1.6323		A38.0124	1	SPACER WASHER	42 X 52 X 2,5	B2
N1.6324		A38.0129	1	SPACER WASHER	19 X 26 X 1	D5
N1.6701		L2.1114	2	TOOTH LOCK WASHER		--
N2.1124		A38.0124	1	SECURITY RING	E24	A2
N2.1204		A38.0125	2	SECURITY RING	J28	B4
N2.1302		A38.3127	1	SECURITY RING	8	C1
N2.1505		L2.1419	1	SPRING RING	B 14	E6
N2.1604		A38.0129	1	SECURITY RING	15	C6
N2.2109			2	PARALLEL PIN	8 M6 X 30	D1
N2.2110		A38.0124	2	PARALLEL PIN	4 M6 X 10	C2
N2.2136		A38.0130	1	PARALLEL PIN	4 H6 X 10	D5
N2.2141		A38.0123	1	PARALLEL PIN	4 M6 X 50	A4
N2.2147			1	PARALLEL PIN	3 M6 X 10	D1
N2.2172			2	PARALLEL PIN	5 M6 X 30	E3
N2.4902			4	HAMMER HEAD BOLT	1,85 X 4,76	A7
N2.5102		A38.0123	2	PRESSURE SPRING	0.6 X 8 X 14/6	C3
N2.5131		A38.0123	1	PRESSURE SPRING	0.5X6X15/7,5	B3
N2.5179		A38.0123	1	PRESSURE SPRING	0.32X2.82X34/30.5	C3
N2.5208		A38.0123	1	PRESSURE SPRING	5X60(105)X140/5.5	B5
N2.5209		L2.1419	1	PRESSURE SPRING	1,25X10X20/6,5	E7
N2.5210			1	PRESSURE SPRING	1,5X 8 X 96/40	C3
N2.5604		A38.3401	2	CUP SPRING	31.5X16.3X1.25	B1
N2.5613		A38.3127	49	CUP SPRING	16X8,2X0,9	C1
N2.5617		A38.0124	12	CUP SPRING	50 X 25.4 X 1.5	A2
N3.1102		L2.1114	4	BALL BEARING		--
N3.1108		L2.1114	1	BALL BEARING		--
N3.1109		L2.1114	1	BALL BEARING		--
N3.1131		A38.0129	1	BALL BEARING		E5
N3.1708		A38.0123	2	BALL	10 MM	C3
N3.2314		A38.3208	1	NEEDLE CASE		C7
N3.2324		A38.0130	1	NEEDLE BUSH		D4
N3.2343		A38.0130	1	NEEDLE BUSH		D4
N3.2405		A38.3223	1	INNER RACEWAY		E2
N3.2608		A38.0130	1	PACKING RING		D4
N3.3116		A38.3223	1	SLIDE-BEARING		E2
N3.4108		A38.0129	1	THRUST BEARING CAGE		D5
N3.4311		A38.0129	3	THRUST RACE	17 X 30 X1	C6+
N41.9128			1	ADHESIVE LABEL		A7
N41.9129			1	ADHESIVE LABEL		A7
N4.9141			1	LABEL	<<A384>>	A7
N4.9159			1	LABEL	<<CE>>	A7
N6.3207		A38.0129	1	JOINT		D4

[ ] = Group

\* = Wearing parts

13.6861.01	A384/19/0.50-0.63/6.5		A384.0001.01			04.10.99
Item-No.		in group	Pcs.	Description	Dimension	Field
N6.5133		A38.0123	1	REDUCING COUPLING		D4
N6.5138		A38.0123	1	SEALING SCREW		B4
N6.5195		A38.0129	1	FITTING		E6
N6.5624		A38.0123	1	ANGLE		D4
N6.5667			2	PACKING RING	12 X 15.5 X 1.5	E4
N6.5689			1	HOLLOW SCREW		E4
N6.5691		L2.1419	1	PACKING RING		D6
N6.5694		A38.0123	1	PACKING RING		B4
N6.6115			1	LIP SEAL	16 X 10 X 4	C4
N6.6124		A38.0129	1	PACKING RING	25 X 18 X 2.3	C6
N6.6134		A38.0127	2	SEAL	20 MM	A5
N6.6149		L2.1419	1	CYLINDER SEAL		D6
N6.6150		A38.0125	1	SEAL		B4
N6.6151		A38.0125	1	SEAL		B4
N6.6152		A38.0124	1	SEAL		B2
N6.6205		A38.0123	1	O-RING	9,2 X 1.78	C3
N6.6213		A38.0123	1	O-RING	20 X 2	A5
N6.6217		A38.0126	1	O-RING	15 X 2	A5
N6.6217		A38.0129	1	O-RING	15 X 2	D4
N6.6219			1	O-RING	35 X 3,5	D4
N6.6229		A38.0123	4	O-RING	14 X 1	B3
N6.6230		A38.0123	2	O-RING	8 X 1,5	B3
N6.6235			1	O-RING	12 X 2	C3
N6.6253		A38.3208	1	O-RING	42 X 1,5	C6
N6.6258		A38.0123	1	O-RING	116 X 2	A7
N6.6259		A38.0123	1	O-RING	50 X 2	B3
N6.6312		A38.0126	1	SEAL		B7
N7.1205		A38.3223	2	SEALING DISK		E2

[ ] = Group

\* = Wearing parts

---

## 10 SEAL CONTROL

A regular control of the seal is necessary. The seal can be checked visually and the person controlling can easily judge the quality of the seal. When checking the seal the following illustrations must be compared.

### Correct seal

A correct seal must conform to the illustration. This means that the depth with which the upper strap hooks into the lower one must be 1 - 1.5 mm in min. and 2 mm in max.. The upper strap must be sheared clean and the cutter must not leave scratch marks on the lower strap.



### Incorrect seal (the sealing mechanism is adjusted too high)

This stamped seal is not deep enough and the upper strap is not sheared. The tensile strength of this seal is insufficient and the strapping must be taken away from the package. The tool must be readjusted immediately (see SEAL ADJUSTMENT).



### Incorrect seal (the sealing mechanism is adjusted too low)

This stamped seal is too deep and the lower strap is scratched by the cutter. Although the tensile strength of this seal is sufficient the strapping must be taken away from the package because of the scratched lower strap.

The tool must be readjusted immediately (see SEAL ADJUSTMENT).





## 11 SEAL ADJUSTMENT

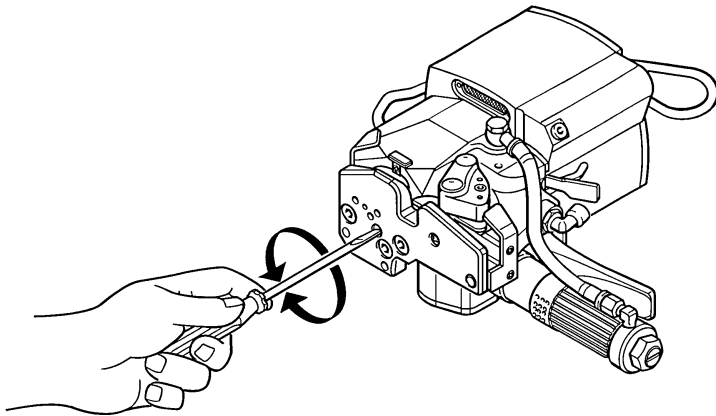

The depth of the sealing mechanism and the cutter can be adjusted by turning the adjusting screw with a screw driver.

### Sealing depth is excessive

Turn adjusting screw counter-clockwise.

A turn of 90° equals a stroke correction of 0.25mm/.010".

### Sealing depth is not sufficient

Turn adjusting screw clockwise.

A turn of 90° equals a stroke correction of 0.25mm/.010".

## 12 MAINTENANCE

Depending on the working conditions and the use of the tool the following maintenance has to be made periodically:

### 12.1 Air unit

- Checking the air-pressure daily (never exceed 87psi / 6 bar)
- Checking oil-level daily
- The water separator must be emptied before it is full (unless automatic).
- The filter has to be cleaned following the instructions of the manufacturer of the air- unit.

### Oil for air unit

HL or CL ISO-VG 10

### 12.2 Cleaning

In case of heavy dirt and when painted straps are used the punch, dies, gripper and feed-wheel must be cleaned regularly.

Normally it is sufficient to blow out the parts with the help of an air gun.

### 12.3 Lubrication

The worm gear is lubricated with MOLYKOTE BR2 PLUS. For relubrication purposes after possible repairs only this type of grease must be used.

All valve parts as well as other movable parts must be lubricated with the grease ESSO BEACON 2 or an equal product when exchanged.

## 12.4 Oil level in the pressure intensifier

### Inspection:

For inspection of the oil level take off plug A38.3116. With full oil reservoir, the compensating piston A38.0127 is located just under the plug. The minimum level is reached, when the top face of the compensating piston is approx. 65 mm (2 1/2") under the bore edge.

Lack of oil in the pressure intensifier results in malfunction of the tool.

### Refilling of oil into the pressure intensifier

- Remove the sealing screw A38.3116.
- Screw a M5 bolt into the compensating piston A38.0127.
- Loosen screw N6.5138 a bit.
- Pull the compensating piston out of the tool.
- Retighten the screw N6.5138.
- Fill oil up to the thread.
- Put in the compensating piston
- Remove the bolt and screw in the plug.
- Turn the tool in such a way, that the screw N6.5138 is in the highest position of the oil container.
- Open the screw N6.5138, so that possible air or excessive oil may escape.
- Fill the bore with oil and retighten the screw

Attention: If the oil has been changed completely (i.e. when die- and cutter support has been exchanged) shake the tool, so that all air can escape.

Type of oil for pressure intensifier: Motor oil SAE 20.

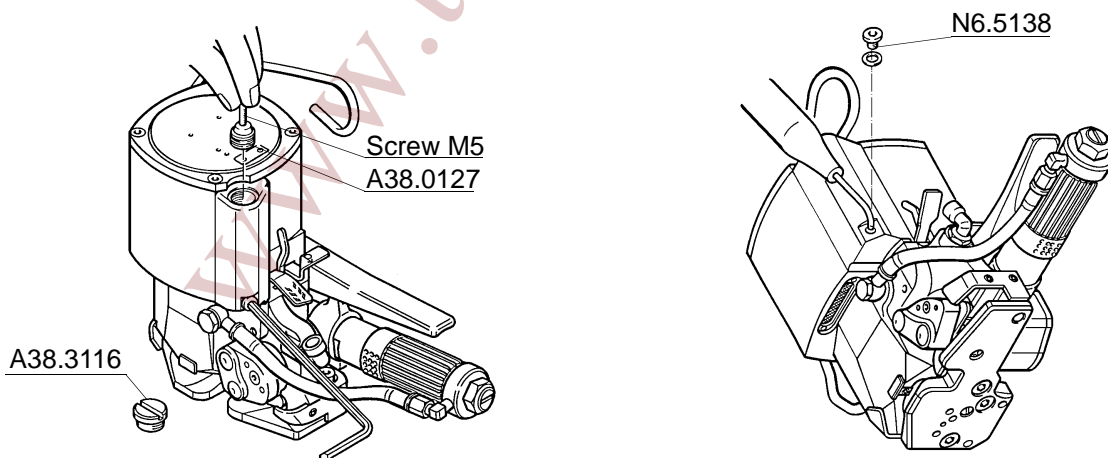

---

## 13 EXCHANGE OF WEARING PARTS

### 13.1 Exchange of the feed-wheel and the gripper

- Remove the cap screw from the bearing cover.
- Pull the air-motor towards the handle.
- Remove the bearing cover, the strap guide, the distance ring and the feed-wheel.
- Screw off the gripper holder.
- Remove it together with the gripper from the base plate.
- Reassemble in opposite order.

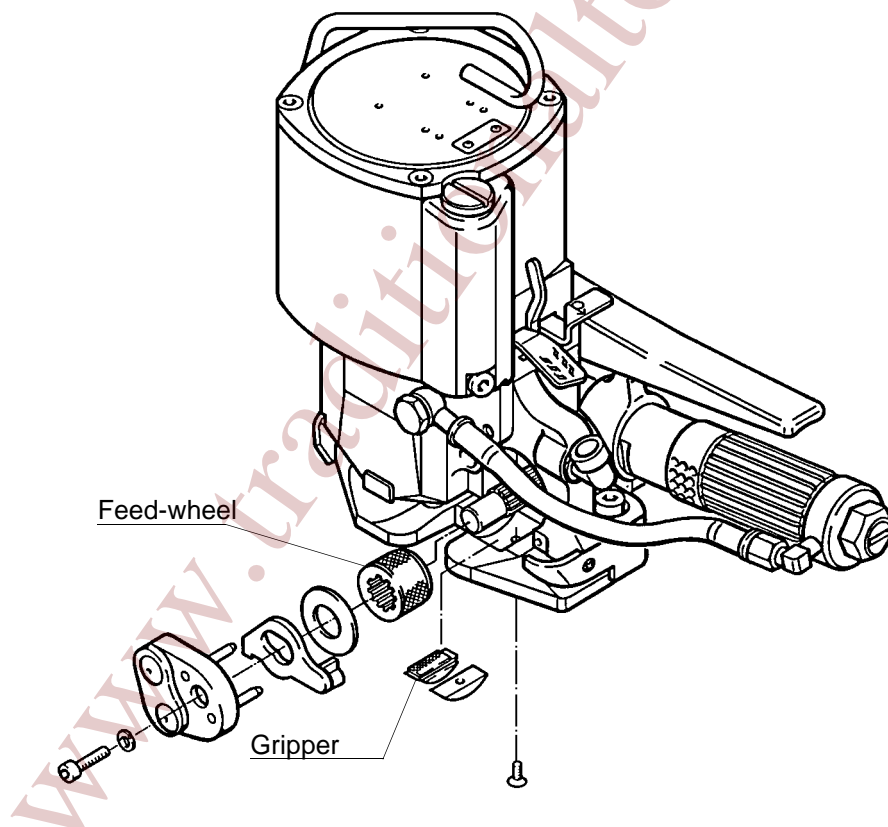

## 13.2 Exchange of punch, dies and cutter

If in spite of a correct adjustment of the sealing depth and a correct oil level no proper sealless joint can be accomplished the wear of the punch and the die halves must be examined.  
Please proceed as follows:

- Disassemble base plate completely.
- Remove screws from punch and die halves.
- Remove all single parts.

If the cutting edges are destroyed or worn heavily the respective parts must be replaced.  
Attention! The cutting edges of the parts are slightly rounded also when they are new.

**Attention!**

***Before mounting the parts they have to be cleaned carefully!***

***When mounting the base plate the screws N1.1106 and N1.1174 must be tightened with 90 Nm (torque wrench).***

