

## FROMM

OPERATION MANUAL / SPARE PARTS LIST

### BATTERY - POWERED PLASTIC STRAPPING TOOL MODEL P330

43.0254.01

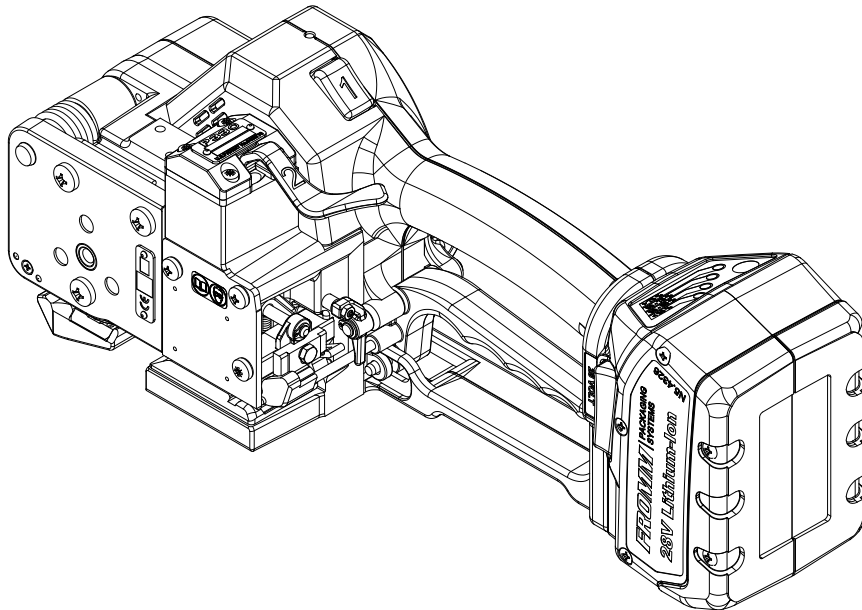

#### CE Declaration of conformity

We declare that the machine P330  
is in conformity with the following standard or  
standardised documents:

98/37/EC (until 28.12. 2009),  
2006/42/EC (from 29.12. 2009 on),  
2004/108/EC

Technical file at:  
FROMM System GmbH  
D-77855 Achern

27.08.2008

A handwritten signature in black ink, appearing to read 'R. Fromm'.

R.Fromm  
Director

FROMM Holding AG  
Hinterbergstrasse 26  
CH - 6330 Cham



	<b>INDEX</b>	<b>PAGE</b>
<b>1</b>	<b>GENERAL SAFETY RULES</b>	<b>3</b>
<b>2</b>	<b>SAFETY RULES FOR STRAPPING TOOLS</b>	<b>5</b>
<b>3</b>	<b>TECHNICAL DATA</b>	<b>6</b>
<b>4</b>	<b>ACCESSORIES</b>	<b>7</b>
4.1	Battery . . . . .	7
4.2	Battery - chargers . . . . .	7
4.3	Wearing plate . . . . .	8
4.4	Suspension . . . . .	8
4.5	Turning button kit . . . . .	9
<b>5</b>	<b>OPERATING ELEMENTS</b>	<b>10</b>
<b>6</b>	<b>OPERATION</b>	<b>10</b>
6.1	Installation . . . . .	10
6.2	Displaying of the status of the battery charge . . . . .	11
6.3	Adjustments . . . . .	11
6.4	Feeding the strap around the package . . . . .	12
6.5	Inserting the strap . . . . .	12
6.6	Tensioning the strap . . . . .	12
6.7	Sealing of the joint . . . . .	13
6.8	Removing the tool . . . . .	13
6.9	Seal - Control . . . . .	13
<b>7</b>	<b>CHART OF TYPES</b>	<b>14</b>
<b>8</b>	<b>ELECTRIC SCHEMATIC</b>	<b>14</b>
<b>9</b>	<b>EXCHANGE OF WEARING PARTS</b>	<b>15</b>
9.1	Exchange of tensioning wheel and grippers . . . . .	15
9.2	Exchange of cutter, welding stop gripper and welding gripper . . . . .	16
9.3	Adjustment of the coupler . . . . .	17
<b>10</b>	<b>SERVICE</b>	<b>17</b>
<b>11</b>	<b>CLEANING</b>	<b>17</b>
<b>12</b>	<b>DISPOSAL</b>	<b>18</b>
<b>13</b>	<b>WARRANTY CONDITIONS AND LIABILITY</b>	<b>18</b>
<b>14</b>	<b>APPROPRIATE USE</b>	<b>18</b>
<b>15</b>	<b>SPARE PARTS LIST 43.0254.01</b>	<b>23</b>

---

# 1 GENERAL SAFETY RULES

**WARNING! Read all instructions.** Failure to follow all instructions listed below may result in electric shock, fire and/ or serious injury. The term "power tool" in all of the warnings listed below refers to your mains operated (corded) power tool or battery operated (cordless) power tool.

SAVE THESE INSTRUCTIONS.

## 1.1 Work area

- a) **Keep work area clean and well lit.** Cluttered and dark areas invite accidents.
- b) **Do not operate power tools in explosive atmospheres, such as in the presence of flammable liquids, gases or dust.** Power tools create sparks which may ignite the dust or fumes.
- c) **Keep children and bystanders away while operating a power tool.** Distractions can cause you to lose control.

## 1.2 Electrical safety

- a) **Power tool plugs must match the outlet. Never modify the plug in any way. Do not use any adapter plugs with earthed (grounded) power tools.** Unmodified plugs and matching outlets will reduce the risk of electric shock.
- b) **Avoid body contact with earthed or grounded surfaces such as pipes, radiators, ranges and refrigerators.** There is an increased risk of electric shock if your body is earthed or grounded.
- c) **Do not expose power tools to rain or wet conditions.** Water entering a power tool will increase the risk of electric shock.
- d) **Do not abuse the cord. Never use the cord for carrying, pulling or unplugging the power tool. Keep cord away from heat, oil, sharp edges or moving parts.** Damaged or entangled cords increase the risk of electric shock.
- e) **When operating a power tool outdoors, use an extension cord suitable for outdoor use.** Use of a cord suitable for outdoor use reduces the risk of electric shock.

## 1.3 Personal safety

- a) **Stay alert, watch what you are doing and use common sense when operating a power tool. Do not use a power tool while you are tired or under the influence of drugs, alcohol or medication.** A moment of inattention while operating power tools may result in serious personal injury.
- b) **Use safety equipment. Always wear eye protection.** Safety equipment such as dust mask, non-skid safety shoes, hard hat, or hearing protection used for appropriate conditions will reduce personal injuries.
- c) **Avoid accidental starting. Ensure the switch is in the off position before plugging in.** Carrying power tools with your finger on the switch or plugging in power tools that have the switch on invites accidents.
- d) **Remove any adjusting key or wrench before turning the power tool on.** A wrench or a key left attached to a rotating part of the power tool may result in personal injury.
- e) **Do not overreach. Keep proper footing and balance at all times.** This enables better control of the power tool in unexpected situations.
- f) **Dress properly. Do not wear loose clothing or jewellery. Keep your hair, clothing and gloves away from moving parts.** Loose clothes, jewellery or long hair can be caught in moving parts.
- g) **If devices are provided for the connection of dust extraction and collection facilities, ensure these are connected and properly used.** Use of these devices can reduce dust related hazards.

---

## 1.4 Power tool use and care

- a) **Do not force the power tool. Use the correct power tool for your application.** The correct power tool will do the job better and safer at the rate for which it was designed.
- b) **Do not use the power tool if the switch does not turn it on and off.** Any power tool that cannot be controlled with the switch is dangerous and must be repaired.
- c) **Disconnect the plug from the power source before making any adjustments, changing accessories, or storing power tools.** Such preventive safety measures reduce the risk of starting the power tool accidentally.
- d) **Store idle power tools out of the reach of children and do not allow persons unfamiliar with the power tool or these instructions to operate the power tool.** Power tools are dangerous in the hands of untrained users.
- e) **Maintain power tools. Check for misalignment or binding of moving parts, breakage of parts and any other condition that may affect the operation of the power tool. If damaged, have the power tool repaired before use.** Many accidents are caused by poorly maintained power tools.
- f) **Keep cutting tools sharp and clean.** Properly maintained cutting tools with sharp cutting edges are less likely to bind and are easier to control.
- g) **Use the power tool, accessories and tool bits etc., in accordance with these instructions and in the manner intended for the particular type of power tool, taking into account the working conditions and the work to be performed.** Use of the power tool for operations different from those intended could result in a hazardous situation.

## 1.5 Battery tool use and care

- a) **Ensure the switch is in the off position before inserting the battery pack.** Inserting the battery pack into power tools that have the switch on invites accidents.
- b) **Recharge only with the charger specified by the manufacturer.** A charger that is suitable for one type of battery pack may create a risk of fire when used with another battery pack.
- c) **Use power tools only with specifically designated battery packs.** Use of any other battery packs may create a risk of injury and fire.
- d) **When the battery pack is not in use, keep it away from other metal objects like paper clips, coins, keys, nails, screws, or other small metal objects that can make a connection from one terminal to another.** Shorting the battery terminals together may cause burns or a fire.
- e) **Under abusive conditions, liquid may be ejected from the battery; avoid contact. If contact accidentally occurs, flush with water. If liquid contacts eyes, additionally seek medical help.** Liquid ejected from the battery may cause irritation or burns.

## 1.6 Service

- a) **Have your power tool repaired only by qualified personnel using original spare parts.** This will ensure that the safety of the power tool is maintained.

---

## 2 SAFETY RULES FOR STRAPPING TOOLS

### 2.1 Joints

**You are fully responsible to review the joints made by your tool. Become familiar with the seal control and seal adjustment described in this operation manual.**

Misformed joints may not secure the load and could cause serious injury. Never handle or ship any load with improperly formed joints.

### 2.2 Dispensing strap

**Only dispense strap from a dispenser specifically designed for strap. Tuck strap end back into dispenser when not in use.**

### 2.3 Strap warnings

**Never use strap as a means of pulling or lifting loads.** Failure to follow these warnings can result in severe personal injury.

### 2.4 Strap breakage hazard

Improper operation of the tool, excessive tensioning, using strap not recommended for this tool or sharp corners on the load can result in a sudden loss of strap tension or in strap breakage during tensioning, which could result in the following:

A sudden loss of balance causing you to fall.

Both tool and strap flying violently towards your face.

Note as follows:

**If the load corners are sharp, use edge protectors.**

**Place the strap correctly around a properly positioned load.**

**Positioning yourself in-line with the strap, during tensioning and sealing, can result in severe personal injury from flying strap or tool. When tensioning or sealing, position yourself to one side of the strap and keep all bystanders away.**

**Use the correct strap quality, strap width, strap gauge and strap tensile strength recommended in this manual for your tool.** Using strap not recommended for this tool can result in strap breakage during tensioning.

### 2.5 Cutting tensioned strap

**When cutting strapping, use the proper strapping cutter** and keep other personnel and yourself at a safe distance from the strap. Always stand to side of the strap, away from the direction the loosened strap end will fly. Use only cutters designed for strap and never hammers, pliers, hacksaws, axes, etc.

### 2.6 Environment protection

Do not dispose of used batteries in the household refuse, water or by burning them.

FROMM distributors offer an environment friendly battery disposal service.

### 3 TECHNICAL DATA

#### Description of the tool

The tool model P330 has been designed to strap packages with plastic strapping. The plastic strapping is fed around the package manually or in combination with a strap feeder. The straps are inserted in the tool, automatically tensioned, sealed by friction welding and separated.

#### Tool size with battery

Length:	395 mm / 14"
Width:	137 mm / 5"
Height:	143 mm / 5"
Weight:	5,7 kg / 12,57 lbs

#### Noise information

The A-weighted equivalent continuous sound level at the work place of the machine operator is typical 84 dB (A). The sound power level is 92 dB (A).  
This value was determined according to DIN EN 60745-1 (12.2003).  
Deviation K: 2.5 dB



**Wear ear protection!**

#### Vibration information

The weighted effective value of the acceleration typically amounts to less than 2.5 m/s<sup>2</sup>.  
This value was determined according to DIN EN 60745-1 (12.2003).  
Deviation K: 0,6 m/s<sup>2</sup>

#### Strap material

Strap qualities:	PET (Polyester) and PP (Polypropylene) plain or embossed. <b>Use only plastic straps recommended by your sales shop (name and address on the rear of the operation manual).</b>
Strap dimensions:	19.0 - 25.0 mm / 3/4 - 1" x 0,40 - 1,53 mm / .016 - .060" (see chart of types). <b>Use only plastic straps with the correct strap dimensions for your tool.</b>

#### Strap tension

Tensioning force*:	Adjustable from 1200 - max. 6000 N / 270 - max. 1350 lbs.
Tensioning speed*:	approx. 70 - 87 mm/s / 2,76 - 3,43 inch/sec.
Joint strength*:	approx. 75% of the tensile strength of the plastic strap.

\* The value depends on the strap quality.

#### Working temperature

The ambient temperature should be between -10° and 45° C (14° and 113°F).  
The best performance is achieved between 15° and 20°C (59° and 68°F).

## 4 ACCESSORIES



Use only parts and accessories mentioned in the operating instruction. Using other parts or accessories can cause injuries to you and other persons.

### 4.1 Battery

The battery is not automatically supplied with the tool and has to be ordered separately under the following item number:

Item-No.	Battery	Voltage	Capacity
N5.4326	Li-Ion	28 VDC	3,0 Ah

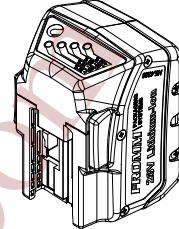

### 4.2 Battery - chargers

The charger must be ordered separately according to below shown table.

Item-No.	Voltage / frequency	Admitted for country
N5.4435	220 - 240V / 50 - 60Hz	A, B, BG, BIH, BOL, BR, BY, CH, CL, CZ, D, DK, DZ, E, EAS, EST, ET, F, FIN, GE, GR, H, HK, HR, I, IL, IND, IR, IRQ, IS, JOR, KSA, KWT, L, LAR, LT, LV, MA, MC, MK, MOC, N, NL, P, PK, PE, PL, PRC, PY, RA, RCH, RI, RL, RO, ROK, ROU, RP, RUS, S, SK, SLO, SYR, THA, TN, TR, UA, UAE, YU, YV, (Z), (ZA), (ZW)
N5.4437	120V / 50 - 60Hz	BR, C, CDN, CO, CR, DOM, EC, GCA, J, JA, KSA, LB, MEX, NIC, PA, Puerto Rico, RC, RP, USA, YV
N5.4439	220 - 240V / 50 - 60Hz	BRN, BRU, CY, EAK, EAT, GB, IRL, M, MAL, OM, SGP, Y
N5.4441	220 - 240V / 50 - 60Hz	AUS, NZ

### 4.3 Wearing plate

In order to protect the P330 when using on packages with hard and rough surface, the tool can be equipped with a wearing plate and a disk for level compensation.

The complete wearing plate together with disk and fastening screws can be ordered under item number P33.0121.

If the complete bottom side of the tool has to be protected, the plate P33.0122 must be used.

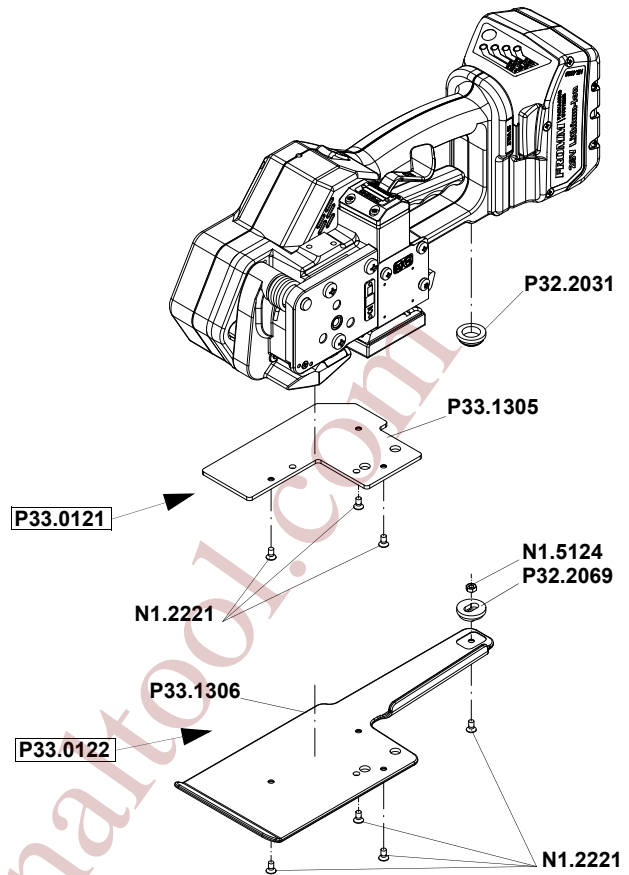

### 4.4 Suspension

When working stationary the P330 can be suspended at a spring loaded balancer by using a suspension bracket.

For working in normal position a stiff suspension bracket with screws and washers can be ordered under item number P32.0112.

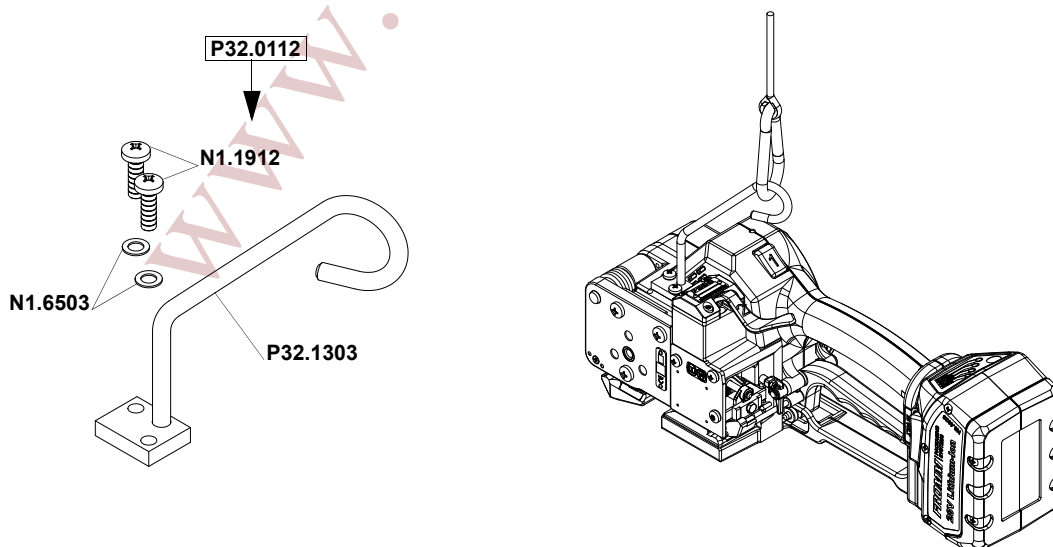



For working in alternating positions a turn able suspension bracket with screws and washers can be ordered under item number P33.0120.

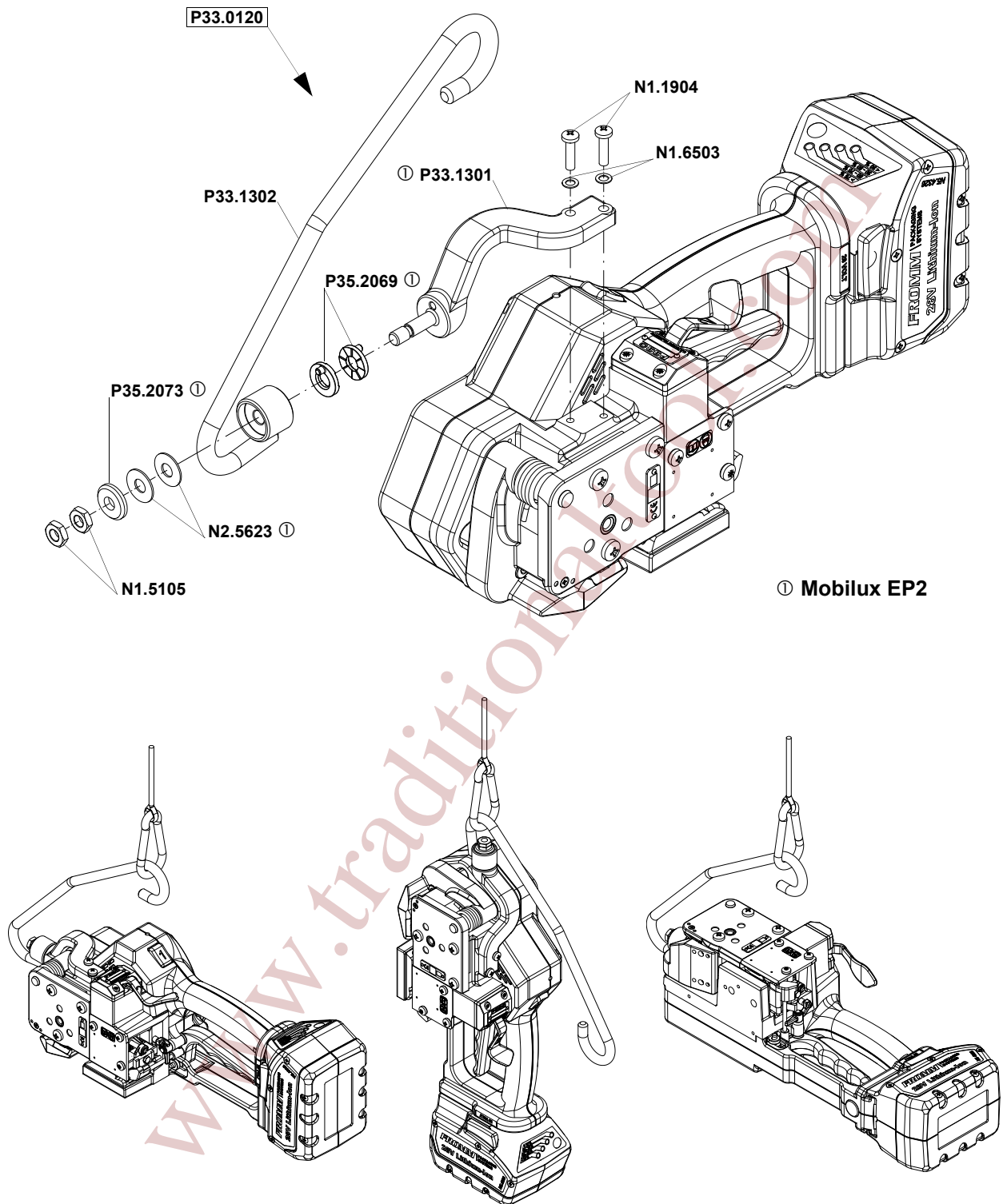

#### 4.5 Turning button kit

For a remaining adjustment of tension force and welding time. After exchanging of the turning buttons the adjustment can only be changed with the allen key (2mm) that comes with the kit. The kit can be ordered under the item number P32.2061.

## 5 OPERATING ELEMENTS

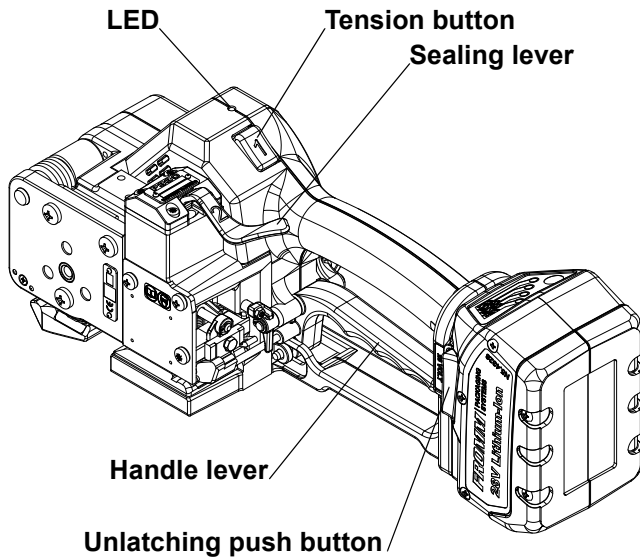

LED - Indication	
Green	During tensioning the LED lights green.
Green	During welding the LED lights green.
Yellow	Cooling time is running, the tool must not be removed from the strap.
Green	Cooling time is finished, the tool can be removed from the strap.
Red blinking	Charge the battery.

## 6 OPERATION

### 6.1 Installation

**Do not expose power tools to rain or wet conditions!**

For safety reasons the battery is delivered uncharged.

Charge the battery before working.

See separate operating instruction of the battery charger.

When charging the battery the very first time, we recommend a charging time of at least 12 hours.

**Never charge a damaged battery. Replace by a new one immediately.**

**Do not open batteries and store them only in dry and frost-proof rooms.**

**The maximum ambient temperature is 50°C.**

**Keep dry at all times.**

### Inserting the battery

Insert the battery from top to bottom into the tool until **both unlatching push buttons are engaged**.

When inserting the battery the LED - indication shortly lights green.

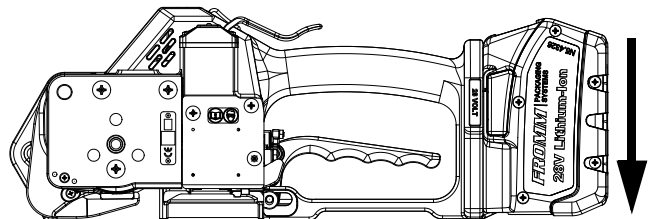

### Removing the empty battery

If the red LED starts blinking while a tensioning or welding procedure, the capacity of the battery is exhausted. All electric functions of the tool are locked.



**The seal efficiency is insufficient.**

**Warning! Straps with insufficient seal strength must be removed from the package!**

The battery must be recharged.

Push the unlatching push buttons at both sides of the battery.

Push the battery out of the tool in the opposite direction of insertion.

## 6.2 Displaying of the status of the battery charge

By pressing a button the status of the battery can be shown in four steps.

If four lamps are lighting the battery is full.

If only one lamp is lighting **shortly** the battery has to be charged.

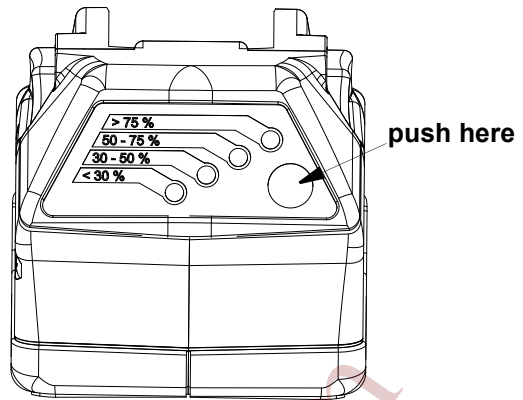

## 6.3 Adjustments

### 6.3.1 Preselecting of strap tension and tensioning speed



**Do not adjust the tensioning force too high.**

**If the tensioning force is higher than the tensioning strength of the strap, the strap will tear while the tensioning.**

Tensioning force and tensioning speed can be preselected with the upper adjusting knob.

Turning clockwise increases;

turning counter clockwise decreases the tensioning force and the tensioning speed at the same time.

The tensioning force on the minimum setting is 1200 N (270 lbs) and it is increased on the maximum setting to 6000 N (1350 lbs).

The tensioning speed on the minimum setting is 70 mm/s (2,76 inch/sec), it is increasing linear up to 87 mm/s (3,43 inch/sec) on the maximum setting.

**Adjusting knob tensioning force / tensioning speed**

**Adjusting knob welding time**

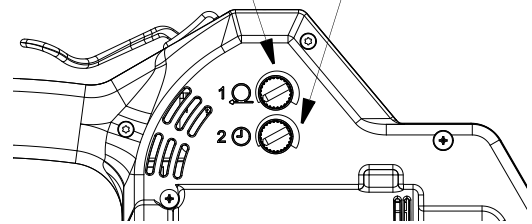

### 6.3.2 Adjusting the welding time

Depending on the size and quality of the strap, different welding times are required.

The welding time can be adjusted at the lower adjusting knob.

Turning clockwise increases,

turning counter clockwise decreases the welding time.

## 6.4 Feeding the strap around the package

The strapping is fed around the package as illustrated.



**Warning!** The plastic strap which will be welded must be free from oil, grease and other dirt.

**Dirty plastic straps can't be welded correct!**

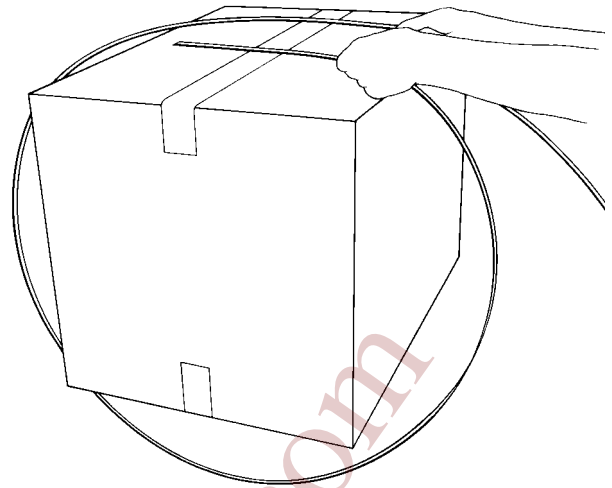

## 6.5 Inserting the strap

Pull up the handle lever firmly with your right hand.

Insert the two straps well aligned on each other into the strap guide using your left hand.

Release the handle lever.

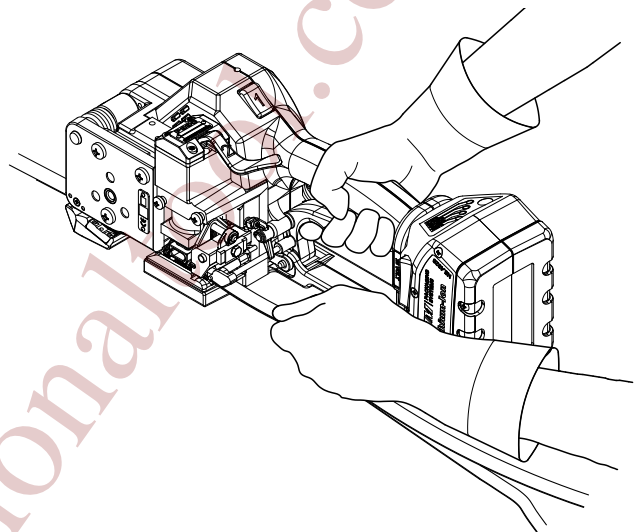

## 6.6 Tensioning the strap

Press down the tension button and then release it again after the desired strap tension has been reached.

The tensioning operation can be interrupted and restarted at any time.

During tensioning the LED lights green.

**Do not press the tension button after reaching the preselected tensioning.**  
**Danger of strap breakage.**

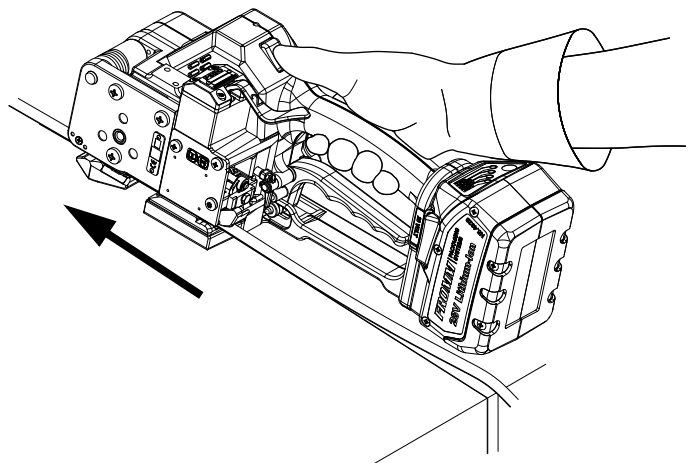

The tool must carry out a balance movement while tensioning.

Therefore:

- Don't hinder the tools movement in the signed direction.

Disregard:

- The feed wheel slips on the strap without tensioning it.

## 6.7 Sealing of the joint

Press sealing lever down until it locks and let it go immediately.  
The plastic strap is welded and cut off from the rest of the strap.  
During the welding the LED lights green.

After elapsing of the adjusted welding time (see 6.2.2) the cooling time begins (LED lights yellow).  
During that time the tool must not be removed from the strap.  
If the LED lights green again, the sealing cycle is finished.

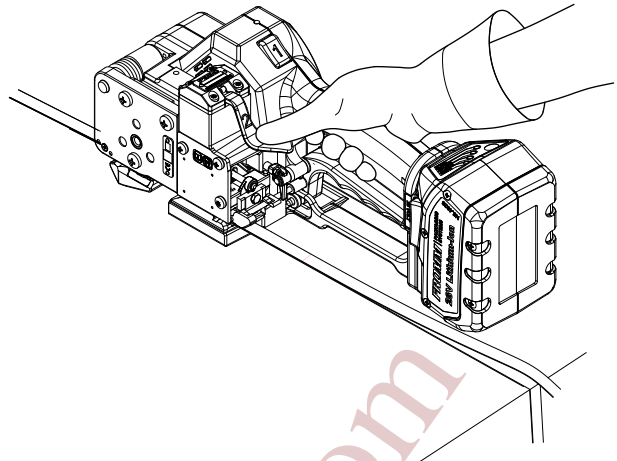

**The tool must not be removed from the strap as long as the cooling time is not finished. Disregard of this regulation is causing insufficient seal efficiencies, which can cause severe injuries.**

## 6.8 Removing the tool

Pull up the handle lever,  
pull the tool right / backwards and off the strapping.

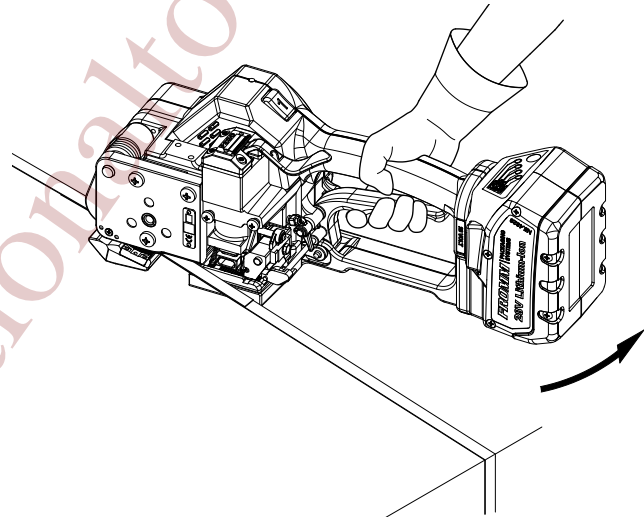

## 6.9 Seal - Control

A regular control of the seal is necessary. The seal can be examined visually.  
Make a seal, peel it apart and examine it as follows:



### Correct seal

The seal must be completely welded over the whole width of the strap on a length of ca. 19 mm. Minor quantities of fused plastic may overflow on sides.



### Welding time too short

The plastic strap is not welded over the whole width of the strap. The seal efficiency is insufficient.  
Warning! Straps with insufficient seal strength must be removed from the package! Adjust the welding time (see 6.2.2).



### Welding time too long

If the welding time is too long the straps are overheated. The fused plastic overflows on both sides of the straps. The seal efficiency is affected.  
Warning! Straps with insufficient seal strength must be removed from the package! Adjust the welding time (see 6.2.2).

## 7 CHART OF TYPES

Item No.	Model	Strap width	Strap thickness
43.0254	P330/19/0.80-1.19	19 mm / 3/4"	0.80-1.19 mm / .031 - .047"
43.0256	P330/19/1.20-1.53	19 mm / 3/4"	1.20-1.53 mm / .047 - .060"
43.0262	P330/25/0.40-0.79	25 mm / 1"	0.40-0.79 mm / .016 - .031"
43.0264	P330/25/0.80-1.19	25 mm / 1"	0.80-1.19 mm / .031 - .047"
43.0266	P330/25/1.20-1.35	25 mm / 1"	1.20-1.35 mm / .047 - .053"

## 8 ELECTRIC SCHEMATIC

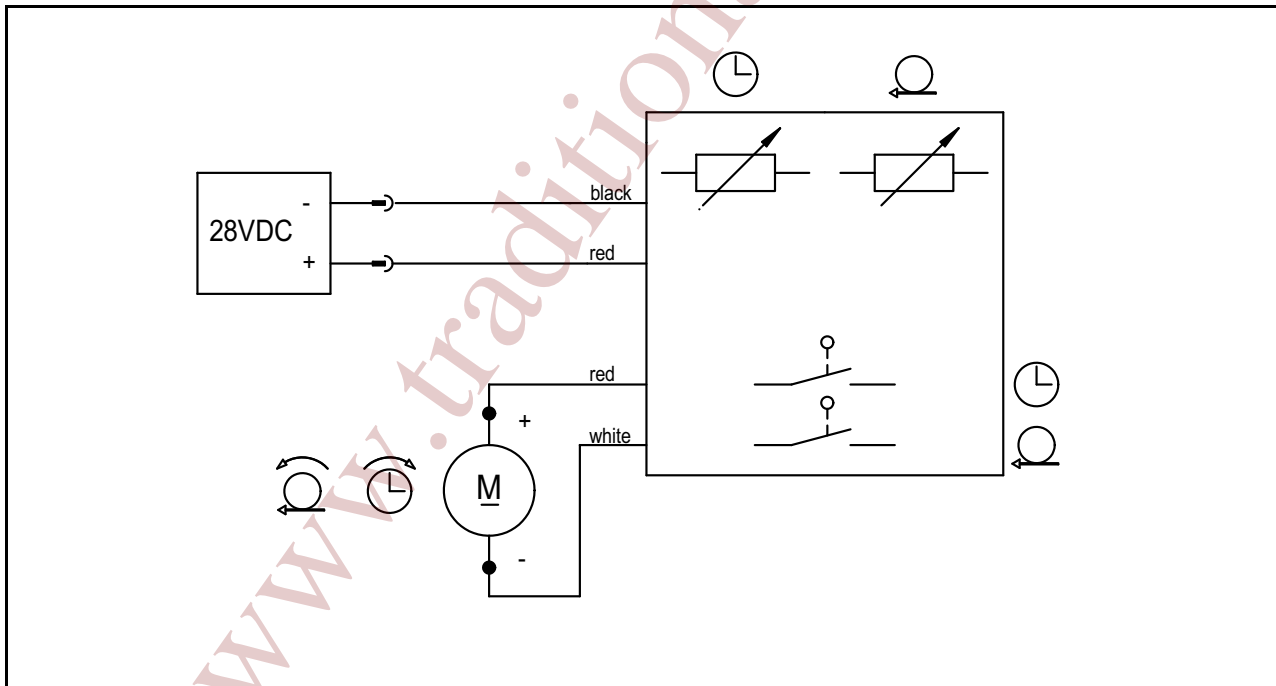

## 9 EXCHANGE OF WEARING PARTS



Remove always the battery from the tool before starting maintenance works.

### 9.1 Exchange of tensioning wheel and grippers

#### Disassembling

- Unscrew end cover P33.0107 and remove it;
- Remove the torsion spring N2.5842;
- Remove the tensioning body P33.0106;
- Remove the tensioning wheel together with the bearing N31.1121 from the tool;
- Unscrew the holders P33.1249 and P33.1250 and remove them from the tensioning body;
- Remove the grippers from the tensioning body.

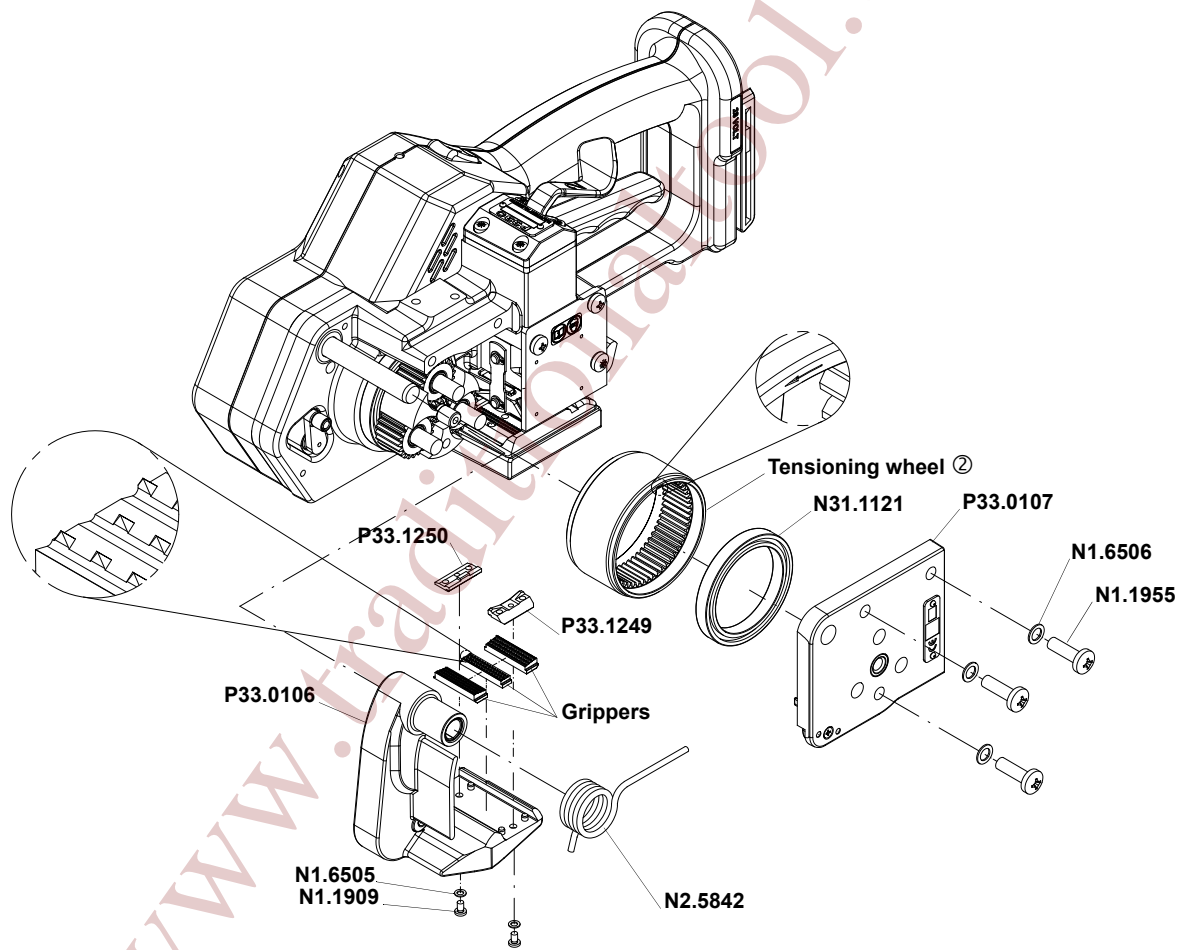

② Molykote BR2 plus

#### Assembling

Assembling in opposite order. Observe the following:

- Lubricate the internal tothing of the tensioning wheel with Molykote BR 2 plus.



**Observe the position of the tensioning wheel. The direction of rotation of the tensioning wheel is marked at the front of the tensioning wheel (see drawing).  
Observe the position of the grippers (see drawing).**

## 9.2 Exchange of cutter, welding stop gripper and welding gripper

### Disassembling

- Unscrew cover P33.1242 and remove it
- Unscrew end cover P33.0107 and remove it;
- Remove the torsion spring N2.5842 and the tensioning body P33.0106;
- Remove the tensioning wheel together with the bearing N31.1121 from the tool;
- Disassemble the security ring N2.1118 and remove the lever P32.1422 from the handle shaft;
- **Don't** loosen screw N1.1553 at the coupler P33.0119.
- Disassemble the security ring N2.1121 from the coupler P33.0119, remove the coupler;
- Pull out the centering sleeve P33.1241 from the guide case to left, disassemble the guide case;
- Pull out the pressure spring N2.5237 with a screw driver from the cutter P33.1230;
- Remove the cutter from the driving pin P33.1221;
- Disassemble the screws N1.1305, lift slightly the welding stop gripper P33.1217 and the steel insert P33.1216 and remove them from the tool;
- Push the steel insert without welding stop gripper under the welding gripper P33.1218 until it touches the parallel pin N2.2110;
- Press down lever P33.1260, if the welding gripper does not sit on the steel insert, put a piece of plastic strap between welding gripper and steel insert.
- Disassemble the safety ring N2.1121 from the bolt P33.1219, remove the bolt from the welding gripper;
- Press in coupler P33.1210 in order to release the lever P33.1260 again;
- Pull out the steel insert with care to right under the welding gripper;
- Disassemble the security rings N2.1121 from the driving pin P33.1221, remove the driver P33.1220 from the driving pin;
- Lift the rocker P33.1214 behind the welding gripper with a screw driver, remove the welding gripper together with the ball cage P32.1027 and the balls N3.1702 from the tool;
- Lower the rocker, remove the thrust piece P32.1029 from the tool.

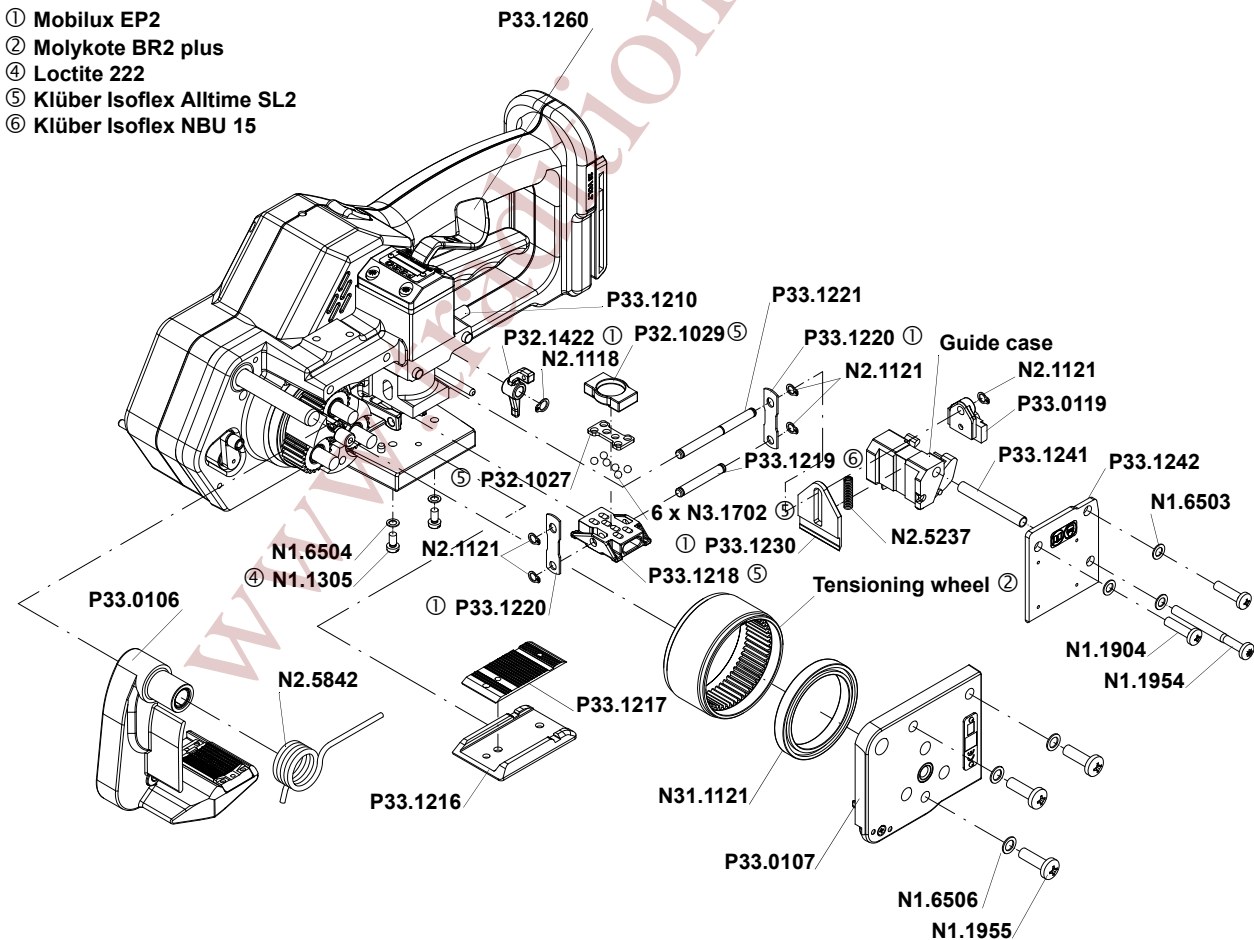



## Assembling

Assembling in opposite order. Observe the following:



**Pay attention to the fitting position of the cutter (see drawing).**

**Safe the screws N1.1305 with Loctite 222.**

**Observe the position of the tensioning wheel. The direction of rotation of the tensioning wheel is marked at the front of the tensioning wheel (see 9.1).**

## Lubrication

- Lubricate the rocker and the bolt P33.1219 in the area of the welding jaw with Klüber Isoflex NBU 15.
- Lubricate the balls, ball cage and the running surface of the balls on the welding gripper with Klüber Isoflex Alltime SL2.
- Lubricate the cutter and the driver with Mobilux EP2.
- Lubricate the internal toothing of the tensioning wheel with Molykote BR 2 plus.

## 9.3 Adjustment of the coupler

The coupler is adjusted in our works.

In case of replacing the seesaw lever, the coupler or the lever body, the coupler has to be readjusted.

Procedure as follows:

The battery is removed from the tool.

The coupler is fitted into the tool.

- Loosen screw N1.1553.
- Displace thrust piece, so that it touches the two seesaw levers without moving them.
- Retighten screw N1.1553.

### Control:

The thrust piece must touch the seesaw levers (X1).

Both guide pins must sit on the welding stop gripper (X2).

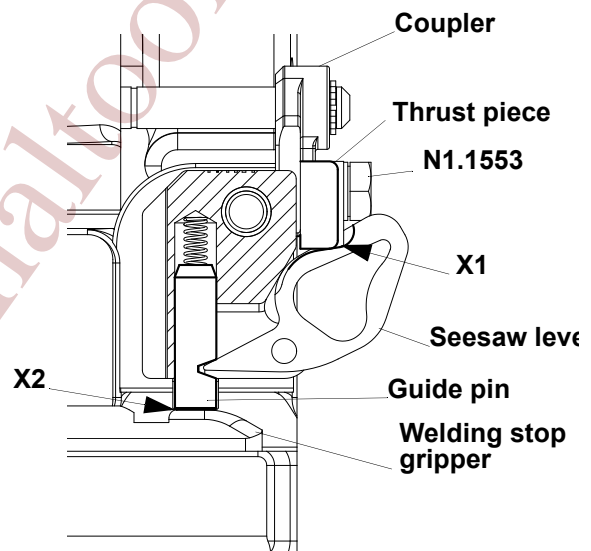

## 10 SERVICE

Servicing and repair work must only be carried out by authorized FROMM service centres.

If the tool breaks down or does no longer operate do not disassemble it. Send it fully assembled to the local FROMM service centre (see name and address on the rear page of this manual). Use original packing.

The battery powered plastic strapping tool P330 is a high performance tool. We strongly recommend you to have it serviced by an authorized FROMM service shop after 12 months at the latest if used one shift per day. If used two or more shifts per day the tool has to be serviced after a shorter period of time.

## 11 CLEANING

Clean tension- and sealing parts from strap abrasion regularly using compressed air (do not use any mechanical tool for cleaning).

When cleaning the surface of the tool do not use water or aggressive solvents!

---

## 12 DISPOSAL

The machine, accessories and packaging should be sorted for environmental-friendly recycling.

### Only for EC countries:

Do not dispose of power tools into household waste!  
According to the European Guideline 2002/96/EC for Waste Electrical and Electronic Equipment and its implementation into national law, power tools that are no longer usable must be collected separately and disposed of in an environmentally correct manner.

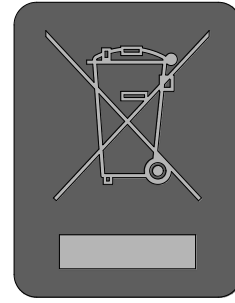

## 13 WARRANTY CONDITIONS AND LIABILITY

FROMM Holding AG warrants all its strapping tools and machine heads during a period of 24 months from the date of installation at the end-user's sight by the distributor, however, not later than 30 months from the date of shipment to the distributor of FROMM Holding AG.

The warranty includes all deficiencies clearly resulting from poor manufacturing or faulty materials. Damage claims as a result of production shutdowns and claims for damage to persons and to property resulting from warranty deficiencies cannot be asserted by the customer.

The warranty excludes:

- wearing parts (tensioning wheels, cutters, punches, dies, notching knives, grippers, batteries and motors),
- deficiencies resulting from improper installing, incorrect handling and maintaining the tool,
- deficiencies resulting from using the tool without or with defective security- and safety devices,
- disregard of directions in the operation manual,
- arbitrary modifications of the tool,
- deficient control of wearing parts,
- deficient repair works of the tool,
- use of consumable products not recommended by FROMM Holding AG.

We reserve the right to modify the product at any time in order to improve its quality.

## 14 APPROPRIATE USE

The tool model P330 has been designed to strap packages with plastic strapping exclusively.

The warranty / liability excludes:

- non appropriate use of the tool,
- disregard of directions in the operation manual,
- disregard of control- and maintenance instructions.

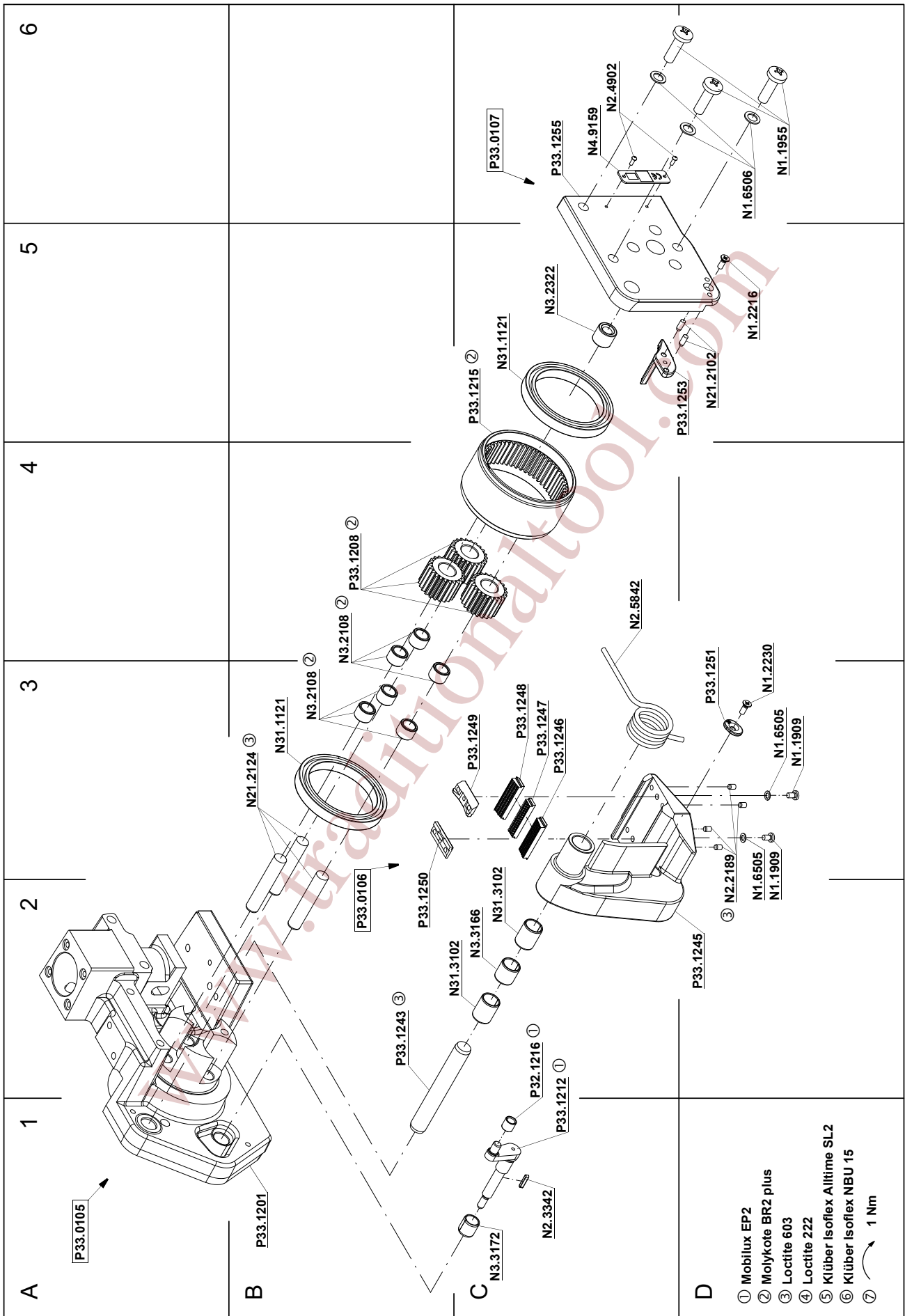

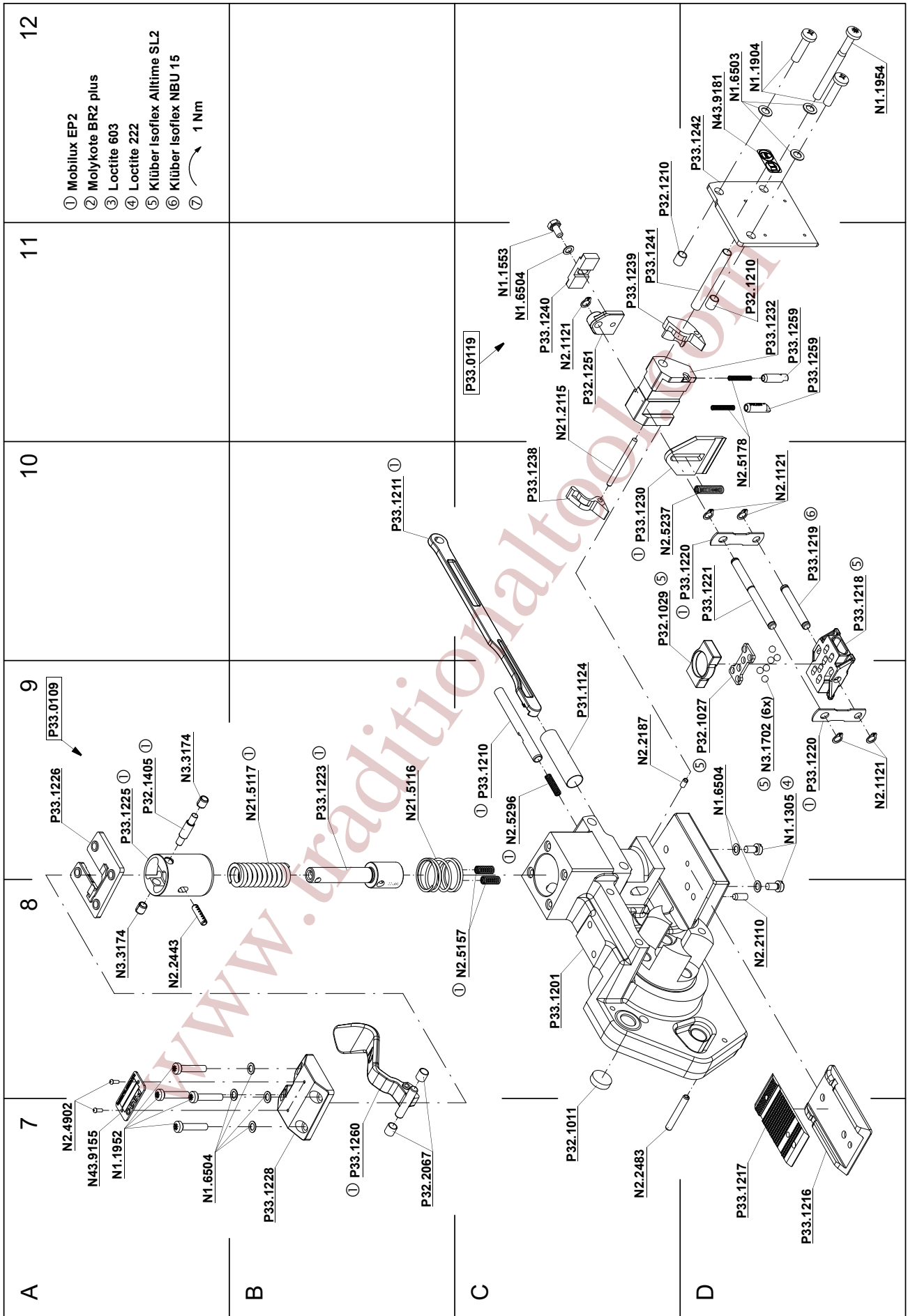

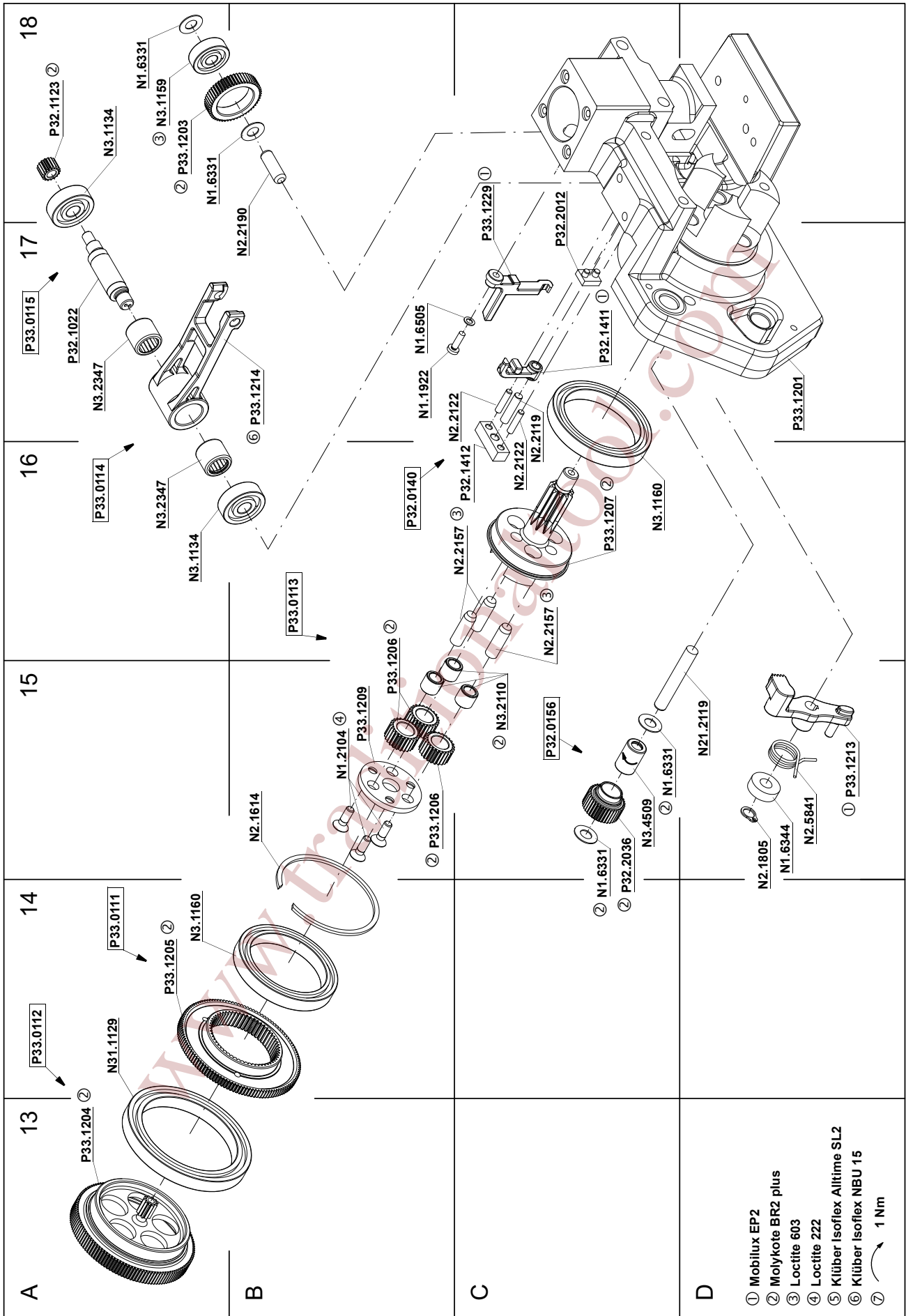

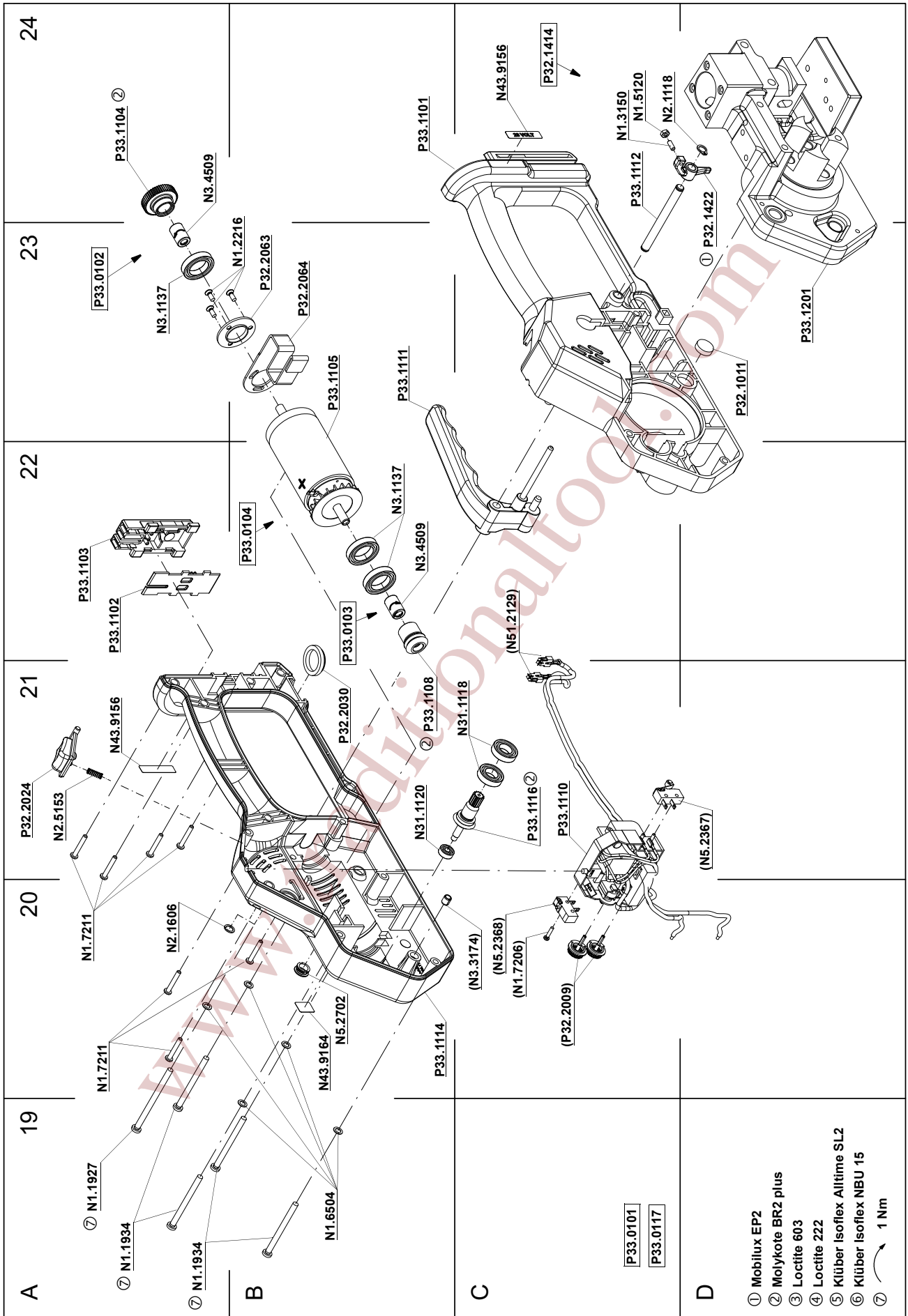

## 15 SPARE PARTS LIST 43.0254.01

43.0254.01	P330/19.0/0.80-1.19/6.0		P330.0001.01			17.02.09
Item-No.		in group	Pcs.	Description	Dimension	Field
N1.1305		P33.0117	2	SCREW	M4 X 7.8	D9
N1.1553		P33.0119	1	HEXAGON SCREW	M4 X 8	C11
N1.1904			2	SCREW	M5 X 20	D12
N1.1909			2	FLAT HEAD SCREW	M3 X 5	D3
N1.1922		P33.0117	1	SCREW	M3 X 10	B17
N1.1927		P33.0117	1	FLAT HEAD SCREW	M4 X 60	A19
N1.1934		P33.0117	4	FLAT HEAD SCREW	M4 X 50	A19
N1.1952		P33.0117	4	FLAT HEAD SCREW	M4 X 20	A7
N1.1954			1	SCREW	M5 X 55	D12
N1.1955			3	SCREW	M6 X 20	D6
N1.2104		P33.0113	3	COUNTERSUNK SCREW	M4 X 12	B15
N1.2216			1	COUNTERSUNK SCREW	M3 X 8	D5
N1.2216		P33.0104	3	COUNTERSUNK SCREW	M3 X 8	B23
N1.2230			1	COUNTERSUNK SCREW	M3 X 10	D3
N1.3150		P32.1414	1	SOCKET SET SCREW	M3 X 8	C24
N1.5120		P32.1414	1	HEXAGON NUT	M3	C24
N1.6331		P33.0117	4	SPACER WASHER	6 X 12 X 0.5	A18+
N1.6344		P33.0117	1	SPACER PIECE	6.3 X 15 X 5	D15
N1.6503			3	SAFETY WASHER	M5	D12
N1.6504		P33.0117	11	SAFETY WASHER	M4	B19+
N1.6504		P33.0119	1	SAFETY WASHER	M4	C11
N1.6505			2	SAFETY WASHER	M3	D3
N1.6505		P33.0117	1	SAFETY WASHER	M3	B17
N1.6506			3	SAFETY WASHER	M6	D6
N1.7206		P33.1110	1	PT-SCREW	2.2 X 10	C20
N1.7211		P33.0101	7	PT-SCREW	3 X 20	A20
N21.2102		P33.0107	2	PARALLEL PIN	3 m6 X 8	D5
N21.2115			1	PARALLEL PIN	3 m6 X 40	C11
N21.2119		P33.0117	1	PARALLEL PIN	6 h6 X 40	D15
N21.2124		P33.0105	3	PARALLEL PIN	8 h6 X 45	B3
N21.5116		P33.0117	1	PRESSURE SPRING	1.5 X 21.0 X 32/5.5	B9
N21.5117		P33.0109	1	PRESSURE SPRING	2.6 X 15 X 56/11.5	B9
N2.1118		P33.0101	1	SECURITY RING	6	C24
N2.1121			1	SECURITY RING	5	C11
N2.1121		P33.0117	4	SECURITY RING	5	D9+
N2.1606		P33.0101	1	SPRING RING	SW6	A20
N2.1614		P33.0117	1	SPRING RING		B15
N2.1805		P33.0117	1	TENSIONING RING	6	D15
N2.2110		P33.0105	1	PARALLEL PIN	4 m6 X 10	D8
N2.2119		P32.0140	1	PARALLEL PIN	4 m6 X 18	C17
N2.2122		P32.0140	2	PARALLEL PIN	3 h6 X 14	C17+
N2.2157		P33.0113	3	PARALLEL PIN	6 h6 X 20	C16
N2.2187		P33.0105	1	PARALLEL PIN	3 m6 X 6	C9
N2.2189		P33.0106	4	PARALLEL PIN	3 m6 X 5	D3
N2.2190		P33.0117	1	PARALLEL PIN	6 h6 X 18	B17
N2.2443		P33.0109	1	DOWEL PIN	4 X 15	A8
N2.2483		P33.0105	1	DOWEL PIN	4 X 30	C7
N2.3342		P33.0117	1	FEATHER KEY	2 X 2 X 10	C1
N2.4902			4	HAMMER HEAD BOLT	1.85 X 4.76	A7+
N2.5153		P33.0101	1	PRESSURE SPRING	0.4 X 4.1 X 16/10.5	A21
N2.5157		P33.0117	2	PRESSURE SPRING	0.6 X 4.8 X 20/15.5	C8

[ ] = Group

\* = Wearing parts

43.0254.01	P330/19.0/0.80-1.19/6.0		P330.0001.01		17.02.09	
Item-No.		in group	Pcs.	Description	Dimension	Field
N2.5178			2	PRESSURE SPRING	0.32 X 2.82 X 20.5/ 20.5	D10
N2.5237			1	PRESSURE SPRING	0.8 X 4.8 X 25/18.5	C10
N2.5296		P33.0117	1	PRESSURE SPRING	0.5 X 4 X 24/16.5	C9
N2.5841		P33.0117	1	TORSION SPRING	1.25 X 12/3.75	D15
N2.5842			1	TORSION SPRING	3 X 19/5	C4
N31.1118		P33.0101	2	BALL BEARING	10 X 19 X 5	C21
N31.1120		P33.0101	1	BALL BEARING	4 X 11 X 4	B21
N31.1121			2	BALL BEARING	45 X 58 X 7	B3+
N31.1129		P33.0112	1	BALL BEARING	50 X 65 X 7	A14
N31.3102		P33.0106	2	SLIDE-BEARING	10 X 12 X 15	C2
N3.1134		P33.0115	1	BALL BEARING	7 X 22 X 7	A18
N3.1134		P33.0117	1	BALL BEARING	7 X 22 X 7	A16
N3.1137		P33.0101	2	BALL BEARING	15 X 24 X 5	B22
N3.1137		P33.0102	1	BALL BEARING	15 X 24 X 5	A23
N3.1159		P33.0117	1	BALL BEARING	6 X 19 X 6	A18
N3.1160		P33.0111	1	BALL BEARING	40 X 52 X 7	A14
N3.1160		P33.0113	1	BALL BEARING	40 X 52 X 7	C16
N3.1702		P33.0117	6	BALL	4 MM	D9
N3.2108			6	NEEDLE CAGE	K 8 X 11 X 8 TN	B3+
N3.2110		P33.0113	3	NEEDLE CAGE	K 6 X 9 X 8 TN	C15
N3.2322		P33.0107	1	NEEDLE CASE	8 X 12 X 10	C5
N3.2347		P33.0114	2	NEEDLE BUSH	10 X 14 X 12	A16+
N3.3166		P33.0106	1	SLIDE-BEARING	10 X 12 X 12	C2
N3.3172		P33.0105	1	SLIDE-BEARING	8 X 10 X 10	C1
N3.3174		P33.0109	2	SLIDE-BEARING	4 X 5.5 X 6	A8+
N3.3174		P33.1114	1	SLIDE-BEARING	4 X 5.5 X 6	C20
N3.4509		P32.0156	1	NEEDLE FREE WHEELING	6 X 10 X 15	C15
N3.4509		P33.0102	1	NEEDLE FREE WHEELING	6 X 10 X 15	A24
N3.4509		P33.0103	1	NEEDLE FREE WHEELING	6 X 10 X 15	B22
N43.9155			1	TYPE PLATE	<<P330>>	A7
N43.9156		P33.0101	2	ADHESIVE LABEL	28 VOLT	C24+
N43.9164			1	ADHESIVE LABEL	WEEE	B20
N43.9181			1	ADHESIVE LABEL	20 X 10 X 0.1	D12
N4.9159			1	LABEL	<<CE>>	C6
N51.2129		P32.2046	1	CONTACT PLUG		C22
N51.2129		P32.2048	1	CONTACT PLUG		C22
N5.2367		P33.1110	1	MICRO SWITCH		D21
N5.2368		P33.1110	1	MICRO SWITCH		C20
N5.2702			1	COVER		B20
P31.1124		P33.0117	1	TUBE		C9
[P32.0140]		P33.0117	1	INSERTATION PART		B16
[P32.0156]		P33.0117	1	GEAR WHEEL		C15
P32.1011		P33.0101	1	FELT		C7
P32.1011		P33.0117	1	FELT		D23
P32.1022		P33.0115	1	WELDING EXCENTRIC		A17
P32.1027		P33.0117	1	BALL CAGE		D9
P32.1029		P33.0117	1	THRUST PIECE		C10
P32.1123		P33.0115	1	PINION		A18
P32.1210			2	CENTERING SLEEVE		C12+
P32.1216			1	PRESSURE ROLLER		C2
P32.1251		P33.0119	1	COUPLER		C11
P32.1405		P33.0109	1	ROLLER		A9

[ ] = Group

\* = Wearing parts



43.0254.01	P330/19.0/0.80-1.19/6.0		P330.0001.01		17.02.09	
Item-No.		in group	Pcs.	Description	Dimension	Field
P32.1411		P33.0117	1	LEVER		C17
P32.1412		P32.0140	1	INSERTATION PART		C16
[P32.1414]		P33.0101	1	LEVER		C24
P32.1422		P32.1414	1	LEVER		D24
P32.2009		P33.1110	2	TURNING BUTTON		C20
P32.2012		P33.0117	1	GUIDE		C18
P32.2024		P33.0101	1	PRESSURE BUTTON		A21
P32.2030		P33.0101	1	DISK		B21
P32.2036		P32.0156	1	GEAR WHEEL		C15
P32.2063		P33.0104	1	DISK		B23
P32.2064		P33.0104	1	COOLING PLATE		B23
P32.2067		P33.0117	2	CENTERING SLEEVE		B7
[P33.0101]		P33.0117	1	DRIVE		C19
[P33.0102]		P33.0101	1	GEAR WHEEL		A23
[P33.0103]		P33.0101	1	CONICAL GEAR WHEEL		B22
[P33.0104]		P33.0101	1	MOTOR		B22
[P33.0105]		P33.0117	1	BODY		A1
[P33.0106]			1	TENSIONING BODY		B2
[P33.0107]			1	END COVER		C6
[P33.0109]		P33.0117	1	SPRING PACKAGE		A9
[P33.0111]		P33.0117	1	WHEEL		A14
[P33.0112]		P33.0117	1	GEAR WHEEL		A14
[P33.0113]		P33.0117	1	IDLER STEP		B16
[P33.0114]		P33.0117	1	ROCKER		A16
[P33.0115]		P33.0117	1	WELDING EXCENTRIC		A17
[P33.0117]			1	BASE MODEL		C19
[P33.0119]			1	COUPLER		C11
P33.1101		P33.0101	1	MOTOR HOUSING		B24
P33.1102		P33.0101	1	COVER		A22
P33.1103		P33.0101	1	INSERTATION PART		A22
P33.1104		P33.0102	1	GEAR WHEEL		A24
[P33.1105]	*	P33.0104	1	ELECTRIC MOTOR		B23
P33.1108		P33.0103	1	CONICAL GEAR WHEEL		B21
[P33.1110]		P33.0101	1	CIRCUIT BOARD		C21
[P33.1111]		P33.0101	1	HANDLE LEVER		B23
P33.1112		P33.0101	1	HANDLE SHAFT		C24
[P33.1114]		P33.0101	1	MOTOR HOUSING		B20
[P33.1116]		P33.0101	1	PINION		C21
P33.1201		P33.0105	1	BODY		D17
P33.1203		P33.0117	1	GEAR WHEEL		A18
P33.1204		P33.0112	1	GEAR WHEEL		A13
P33.1205		P33.0111	1	WHEEL		A14
P33.1206		P33.0113	3	PINION		B15
P33.1207		P33.0113	1	PLANET SHAFT		C16
P33.1208			3	PINION		B4
P33.1209		P33.0113	1	COVER		B15
P33.1210		P33.0117	1	COUPLER		C9
P33.1211		P33.0117	1	COUPLER		B10
P33.1212		P33.0117	1	FRONT TOGGLE LINK		C1
P33.1213		P33.0117	1	LEVER		D15
P33.1214		P33.0114	1	ROCKER		B17
P33.1215	*		1	TENSIONING WHEEL		C5
P33.1216		P33.0117	1	STEEL INSERT		D7

[ ] = Group

\* = Wearing parts

43.0254.01	P330/19.0/0.80-1.19/6.0			P330.0001.01		17.02.09
Item-No.		in group	Pcs.	Description	Dimension	Field
P33.1217	*	P33.0117	1	WELDING STOP GRIPPER		D7
P33.1218	*	P33.0117	1	WELDING GRIPPER		D10
P33.1219		P33.0117	1	BOLT		D10
P33.1220		P33.0117	2	DRIVER		D10+
P33.1221		P33.0117	1	DRIVING PIN		D10
P33.1223		P33.0109	1	SPRING BOLT		B9
P33.1225		P33.0109	1	SPRING SLIDE		A9
P33.1226		P33.0117	1	FIXING PLATE		A9
P33.1228		P33.0117	1	COVER		B7
P33.1229		P33.0117	1	HOOK		C18
P33.1230	*		1	CUTTER		C10
P33.1232			1	GUIDE CASE		D11
P33.1238			1	SEESAW LEVER		C10
P33.1239			1	SEESAW LEVER		C11
P33.1240		P33.0119	1	THRUST PIECE		C11
P33.1241			1	CENTERING SLEEVE		C11
P33.1242			1	COVER		D12
P33.1243		P33.0105	1	SWIVEL SHAFT		B2
P33.1245		P33.0106	1	TENSIONING BODY		D2
P33.1246	*		1	GRIPPER		C3
P33.1247	*		1	GRIPPER		C3
P33.1248	*		1	GRIPPER		C3
P33.1249			1	HOLDER		C3
P33.1250			1	HOLDER		B2
P33.1251			1	STRAP STOP		D3
P33.1253			1	STRAP GUIDE		D5
P33.1255		P33.0107	1	END COVER		C6
P33.1259			2	GUIDE PIN		D11
[P33.1260]		P33.0117	1	LEVER		B7

[ ] = Group

\* = Wearing parts