

FROMM

OPERATION MANUAL / SPARE PARTS LIST

BATTERY - POWERED PLASTIC STRAPPING TOOL MODEL P331 M/HA

43.0276.01

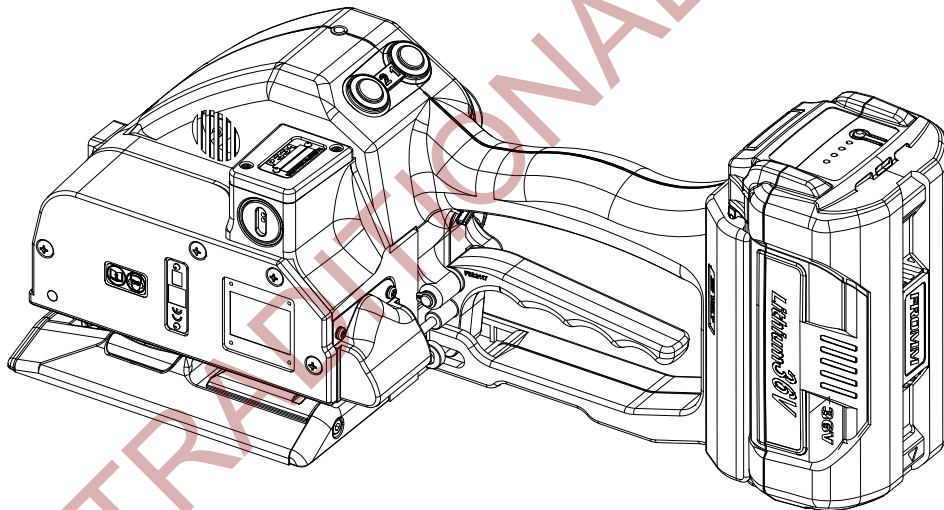

CE Declaration of conformity

We declare that the machine P331 is in conformity with the following standard or standardised documents:

2006/42/EC,
2004/108/EC

Technical file at:

M.Rauch

FROMM System GmbH
Neulandstrasse 10
D-77855 Achern
06.03.2014

R.Fromm
Director

FROMM Holding AG
Hinterbergstrasse 26
CH - 6330 Cham



	INDEX	PAGE
1	GENERAL POWER TOOL SAFETY WARNINGS	3
2	SAFETY RULES FOR STRAPPING TOOLS	5
3	TECHNICAL DATA	6
4	ACCESSORIES	7
4.1	Battery	7
4.2	Battery - chargers	7
4.3	Suspension	8
4.4	Turning button kit	8
4.5	Wearing plate	9
4.6	Protection plate (plastic)	9
5	OPERATING ELEMENTS	9
6	OPERATION	10
6.1	Installation	10
6.2	Adjustments	11
6.3	Feeding the strap around the package	12
6.4	Inserting the strap	12
6.5	Tensioning the strap, Operation mode Manual	12
6.6	Sealing the straps, Operation mode Manual	13
6.7	Tensioning and sealing the strap Operation mode Semi-Automatic	13
6.8	Removing the tool	13
6.9	Seal - Control	14
7	CHART OF TYPES P331 M/HA	14
8	ELECTRIC SCHEMATIC ELS.1084	14
9	EXCHANGE OF WEARING PARTS	15
9.1	Exchange of tensioning wheel and grippers	15
9.2	Exchange of cutter, welding stop gripper and welding gripper	16
9.3	Adjustment of the coupler	17
10	CLEANING	17
11	SERVICE	17
12	TRANSPORT	18
13	DISPOSAL	18
14	WARRANTY CONDITIONS AND LIABILITY	18
15	APPROPRIATE USE	18
16	SPARE PARTS LIST 43.0276.01	23

1 GENERAL POWER TOOL SAFETY WARNINGS

⚠ WARNING! Read all safety warnings and all instructions. Failure to follow the warnings and instructions may result in electric shock, fire and/or serious injury.

Save all warnings and instructions for future reference.

The term “power tool” in the warnings refers to your mainsoperated (corded) power tool or battery-operated (cordless) power tool.

1.1 Work area safety

- a) **Keep work area clean and well lit.** Cluttered or dark areas invite accidents.
- b) **Do not operate power tools in explosive atmospheres, such as in the presence of flammable liquids, gases or dust.** Power tools create sparks which may ignite the dust or fumes.
- c) **Keep children and bystanders away while operating a power tool.** Distractions can cause you to lose control.

1.2 Electrical safety

- a) **Power tool plugs must match the outlet. Never modify the plug in any way. Do not use any adapter plugs with earthed (grounded) power tools.** Unmodified plugs and matching outlets will reduce the risk of electric shock.
- b) **Avoid body contact with earthed or grounded surfaces such as pipes, radiators, ranges and refrigerators.** There is an increased risk of electric shock if your body is earthed or grounded.
- c) **Do not expose power tools to rain or wet conditions.** Water entering a power tool will increase the risk of electric shock.
- d) **Do not abuse the cord. Never use the cord for carrying, pulling or unplugging the power tool. Keep cord away from heat, oil, sharp edges or moving parts.** Damaged or entangled cords increase the risk of electric shock.
- e) **When operating a power tool outdoors, use an extension cord suitable for outdoor use.** Use of a cord suitable for outdoor use reduces the risk of electric shock.
- f) **If operating a power tool in a damp location is unavoidable, use a residual current device (RCD) protected supply.** Use of an RCD reduces the risk of electric shock.

1.3 Personal safety

- a) **Stay alert, watch what you are doing and use common sense when operating a power tool. Do not use a power tool while you are tired or under the influence of drugs, alcohol or medication.** A moment of inattention while operating power tools may result in serious personal injury.
- b) **Use personal protective equipment. Always wear eye protection.** Protective equipment such as dust mask, non-skid safety shoes, hard hat, or hearing protection used for appropriate conditions will reduce personal injuries.
- c) **Prevent unintentional starting. Ensure the switch is in the off-position before connecting to power source and/or battery pack, picking up or carrying the tool.** Carrying power tools with your finger on the switch or energising power tools that have the switch on invites accidents.
- d) **Remove any adjusting key or wrench before turning the power tool on.** A wrench or a key left attached to a rotating part of the power tool may result in personal injury.
- e) **Do not overreach. Keep proper footing and balance at all times.** This enables better control of the power tool in unexpected situations.

- f) **Dress properly. Do not wear loose clothing or jewellery. Keep your hair, clothing and gloves away from moving parts.** Loose clothes, jewellery or long hair can be caught in moving parts.
- g) **If devices are provided for the connection of dust extraction and collection facilities, ensure these are connected and properly used.** Use of dust collection can reduce dust-related hazards.

1.4 Power tool use and care

- a) **Do not force the power tool. Use the correct power tool for your application.** The correct power tool will do the job better and safer at the rate for which it was designed.
- b) **Do not use the power tool if the switch does not turn it on and off.** Any power tool that cannot be controlled with the switch is dangerous and must be repaired.
- c) **Disconnect the plug from the power source and/or the battery pack from the power tool before making any adjustments, changing accessories, or storing power tools.** Such preventive safety measures reduce the risk of starting the power tool accidentally.
- d) **Store idle power tools out of the reach of children and do not allow persons unfamiliar with the power tool or these instructions to operate the power tool.** Power tools are dangerous in the hands of untrained users.
- e) **Maintain power tools. Check for misalignment or binding of moving parts, breakage of parts and any other condition that may affect the power tool's operation. If damaged, have the power tool repaired before use.** Many accidents are caused by poorly maintained power tools.
- f) **Keep cutting tools sharp and clean.** Properly maintained cutting tools with sharp cutting edges are less likely to bind and are easier to control.
- g) **Use the power tool, accessories and tool bits etc. in accordance with these instructions, taking into account the working conditions and the work to be performed.** Use of the power tool for operations different from those intended could result in a hazardous situation.

1.5 Battery tool use and care

- a) **Recharge only with the charger specified by the manufacturer.** A charger that is suitable for one type of battery pack may create a risk of fire when used with another battery pack.
- b) **Use power tools only with specifically designated battery packs.** Use of any other battery packs may create a risk of injury and fire.
- c) **When battery pack is not in use, keep it away from other metal objects, like paper clips, coins, keys, nails, screws or other small metal objects, that can make a connection from one terminal to another.** Shorting the battery terminals together may cause burns or a fire.
- d) **Under abusive conditions, liquid may be ejected from the battery; avoid contact. If contact accidentally occurs, flush with water. If liquid contacts eyes, additionally seek medical help.** Liquid ejected from the battery may cause irritation or burns.

1.6 Service

- a) **Have your power tool serviced by a qualified repair person using only identical replacement parts.** This will ensure that the safety of the power tool is maintained.

2 SAFETY RULES FOR STRAPPING TOOLS

2.1 Joints

You are fully responsible to review the joints made by your tool. Become familiar with the seal control and seal adjustment described in this operation manual.

Misformed joints may not secure the load and could cause serious injury. Never handle or ship any load with improperly formed joints.

2.2 Dispensing strap

Only dispense strap from a dispenser specifically designed for strap.

Tuck strap end back into dispenser when not in use.

2.3 Strap warnings

Never use strap as a means of pulling or lifting loads. Failure to follow these warnings can result in severe personal injury.

2.4 Strap breakage hazard

Improper operation of the tool, excessive tensioning, using strap not recommended for this tool or sharp corners on the load can result in a sudden loss of strap tension or in strap breakage during tensioning, which could result in the following:

A sudden loss of balance causing you to fall.

Both tool and strap flying violently towards your face.

Note as follows:

If the load corners are sharp, use edge protectors.

Place the strap correctly around a properly positioned load.

Positioning yourself in-line with the strap, during tensioning and sealing, can result in severe personal injury from flying strap or tool. When tensioning or sealing, position yourself to one side of the strap and keep all bystanders away.

Use the correct strap quality, strap width, strap gauge and strap tensile strength recommended in this manual for your tool. Using strap not recommended for this tool can result in strap breakage during tensioning.

2.5 Cutting tensioned strap

When cutting strapping, use the proper strapping cutter and keep other personnel and yourself at a safe distance from the strap. Always stand to side of the strap, away from the direction the loosened strap end will fly. Use only cutters designed for strap and never hammers, pliers, hacksaws, axes, etc.

2.6 Environment protection

Do not dispose of used batteries in the household refuse, water or by burning them.

For disposal of the batteries the local laws and prescriptions must be observed.

3 TECHNICAL DATA

Description of the tool

The tool model P331 has been designed to strap packages with plastic strapping. The plastic strapping is fed around the package manually or in combination with a strap feeder. The straps are inserted in the tool, tensioned, sealed by friction welding and separated from the strap coil.

Tool size with battery

Length:	396 mm / 15.6"
Width:	166 mm / 6.5"
Height:	175 mm / 6.9"

Weight

with battery: 6.4 kg / 14.1 lbs

Noise information

The A-weighted equivalent continuous sound level at the work place of the machine operator is typical 82 dB (A). The sound power level is 90 dB (A).

Deviation K: 3 dB

These values were determined according to EN ISO 11204 / EN ISO 3744.



Wear ear protection!

Vibration information

The weighted effective value of the acceleration typically amounts to less than 2.5 m/s².

This value was determined according to DIN EN 60745-1 (12.2003).

Deviation K: 0.6 m/s²

Strap material

Strap qualities: PET (Polyester) plain or embossed.
The plastic strap must be according to DIN EN 13394.

Use only plastic straps recommended by your sales shop (name and address on the rear of the operation manual).

Strap dimensions: 19.0 - 32.0 mm x 0.60 - 1.53 mm (see chart of types).

Use only plastic straps with the correct strap dimensions for your tool.

Operation mode

Manual or Semi-Automatic mode

Strap tension

Tensioning force*: Adjustable from 1200 - max. 7000 N / 270 - max. 1575 lbs.

Tensioning speed*: approx. 39 - 63 mm/s / 1.5 - 2.5 inch/sec.

Seal

Type of seal: Friction weld sealing

Strength of seal*: approx. 75% of the tensile strength of the plastic strap.

* The value depends on the strap quality.

Working temperature

The ambient temperature should be between -10° and 45° C (14° and 113°F).
The best performance is achieved between 15° and 20°C (59° and 68°F).

4 ACCESSORIES



**Use only parts and accessories mentioned in the operating instruction.
Using other parts or accessories can cause injuries to you and other persons.**

4.1 Battery

The battery is not automatically supplied with the tool. The battery has to be ordered separately under the following item numbers.

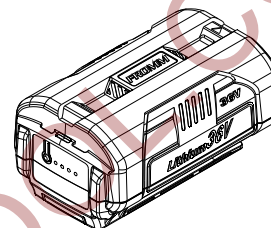

Item-No.	Battery	Voltage	Capacity
N5.4337	Li-Ion	36 VDC	2.5 Ah
N5.4341	Li-Ion	36 VDC	4.0 Ah

4.2 Battery - chargers

The charger must be ordered separately according to below shown table.

Item-No.	Voltage / frequency	Admitted for country
N5.4453	220 - 240V / 50 - 60Hz	A, B, BG, BIH, BOL, BR, BY, CH, CL, CZ, D, DK, DZ, E, EAS, EST, ET, F, FIN, GE, GR, H, HK, HR, I, IL, IND, IR, IRQ, IS, JOR, KSA, KWT, L, LAR, LT, LV, MA, MC, MK, MOC, N, NL, P, PK, PE, PL, PRC, PY, RA, RCH, RI, RL, RO, ROK, ROU, RP, RUS, S, SK, SLO, SYR, THA, TN, TR, UA, UAE, YU, YV, (BRN), (BRU), (CY), (EAK), (EAT), (GB), (IRL), (M), (MAL), (OM), (SGP), (Y), (Z), (ZA), (ZW)
N5.4455	120V / 50 - 60Hz	BR, C, CDN, CO, CR, DOM, EC, GCA, J, JA, KSA, LB, MEX, NIC, PA, Puerto Rico, RC, RP, USA, YV
N5.4457	220 - 240V / 50 - 60Hz	AUS, NZ

Charging times

Item-No.	Battery	Charging time
N5.4337	Li-Ion	approx. 86 min.
N5.4341	Li-Ion	approx. 135 min.

4.3 Suspension

When working stationary the P331 can be suspended at a spring loaded balancer by using a suspension bracket. With the swivel mounted suspension bracket the package can be strapped in various working positions.

The complete suspension bracket can be ordered under item number P33.0216.

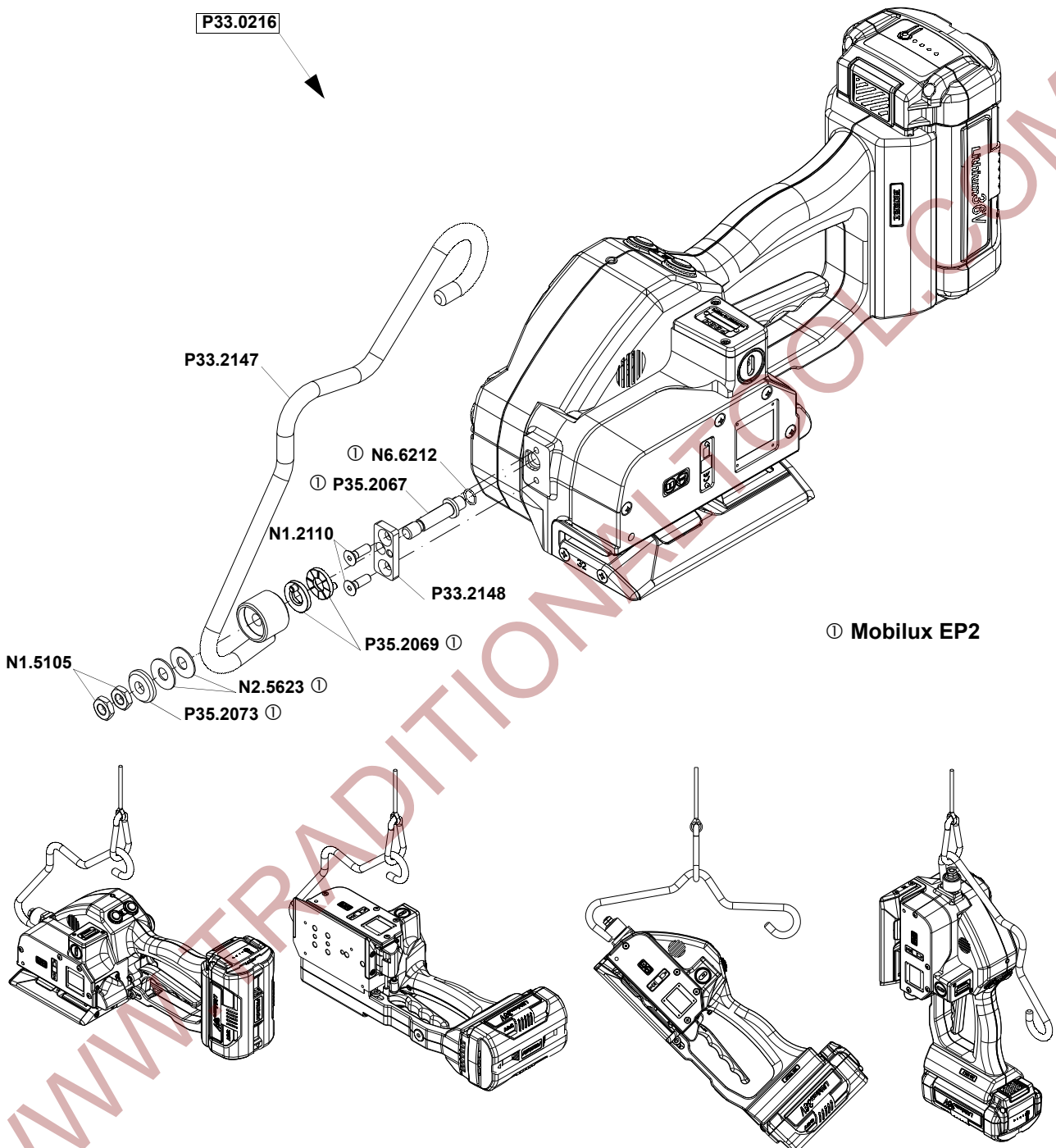

4.4 Turning button kit

For a remaining adjustment of tension force and welding time.

After exchanging of the turning buttons the adjustment can only be changed with the allen key (2mm) that comes with the kit. The kit can be ordered under the item number P32.2061.

4.5 Wearing plate

As an option, the tool can be equipped with a wearing plate to protect the base from excessive wear on abrasive package surfaces.

The complete wearing plate can be ordered together with the fastening screws under item number P33.0214.

4.6 Protection plate (plastic)

For using the P331 on packages with sensitive surface there can a plastic protection plate be mounted for protecting the package.

The complete protection plate can be ordered together with the fastening screws under item number P33.0215.

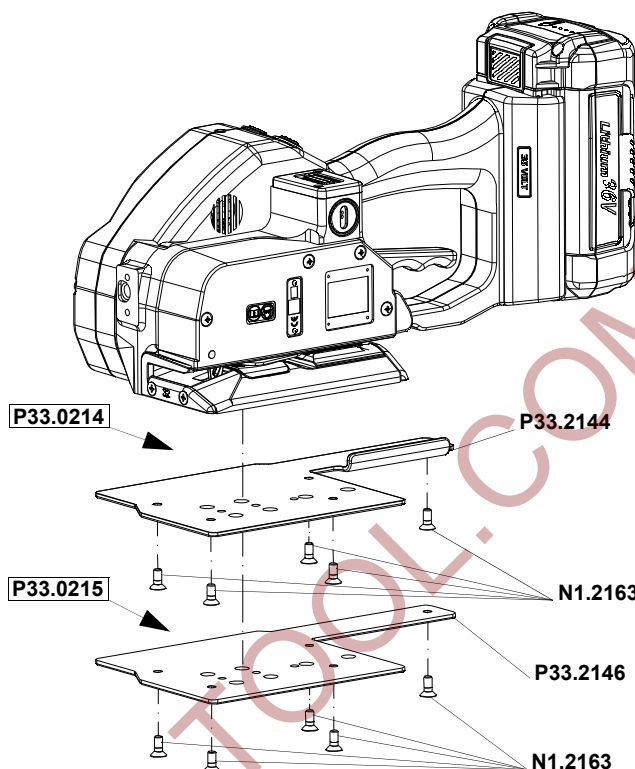

5 OPERATING ELEMENTS

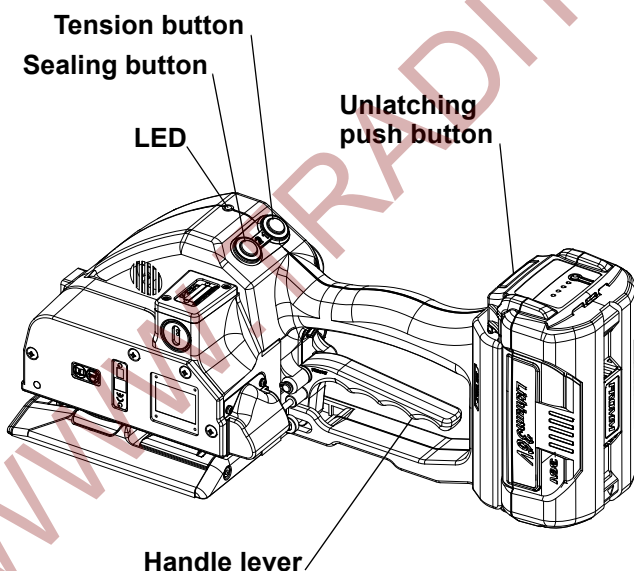

LED - Indication at the tool	
Green	During tensioning the LED lights green.
Blue	Welding is initiated. (only in automatic mode)
Green	During welding the LED lights green.
Yellow	Cooling time is running, the tool must not be removed from the strap.
Blue blinking	Motor overheated, Motor cool down time running. If during this time a switch is operated, an acoustic signal happens.
Green + Acoustic signal	Cooling time is finished; the tool can be removed from the strap.
Red	Charge the battery.
Red blinking	Malfunction: e.g. lowering motor blocked. Remove battery Clear malfunction Insert battery
Without indication	Power saving mode

6 OPERATION

6.1 Installation

Do not expose power tools to rain or wet conditions!

The batteries are supplied partially charged.

Before the first use, the battery must be completely charged.

See separate operating instruction of the battery charger.

Never charge a damaged battery. Replace by a new one immediately.

Do not open batteries and store them only in dry and frost-proof rooms.

Do not store the battery pack together with metal objects (short circuit risk).

The maximum ambient temperature is 50°C.

Keep dry at all times.

Inserting the battery

- Insert the battery from top to bottom into the tool until the unlatching push button is engaged.

When inserting the battery the LED - indication shortly lights green.

Removing the empty battery

If the red LED starts lighting while a tensioning or welding procedure, the capacity of the battery is exhausted. All electric functions of the tool are blocked.

The battery must be recharged.

- Push the unlatching push button at the battery.
- Pull the battery out of the tool.

Displaying of the status of the battery charge

By pressing a button the status of the battery can be shown in four steps.

If four lamps are lighting the battery is full.

If only one lamp is lighting shortly the battery has to be charged.

Unlatching
push button

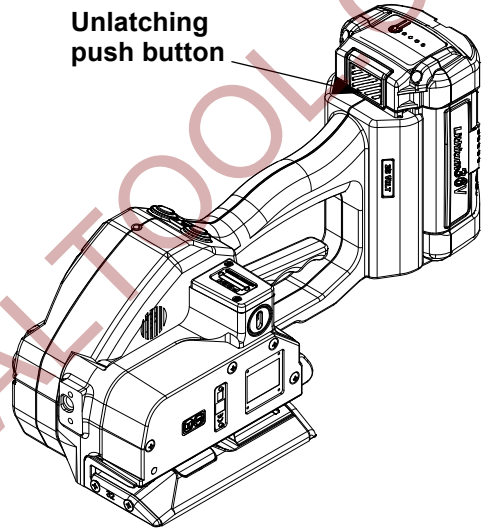

Push here

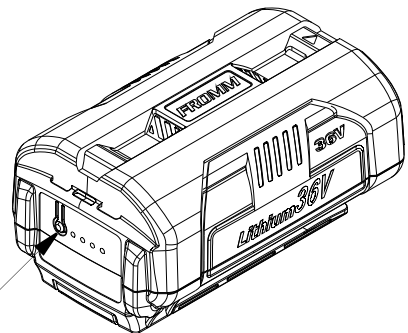

6.2 Adjustments

6.2.1 Preselecting of strap tension and tensioning speed



Do not adjust the tensioning force too high.
If the tensioning force is higher than the tensioning strength of the strap,
the strap will tear while the tensioning.

Tensioning force and tensioning speed can be preselected with the upper adjusting knob.

Turning clockwise increases;
 turning counter clockwise decreases the tensioning force and the tensioning speed resp..

The tensioning force on the minimum setting is 1200 N (270 lbs) and it is increased on the maximum setting to 7000 N (1575 lbs).

The tensioning speed on the minimum setting is 39 mm/s (1.5 inch/sec), it is increasing linear up to 63 mm/s (2.5 inch/sec) on the maximum setting.

Adjusting knob tensioning force / tensioning speed

Adjusting knob welding time

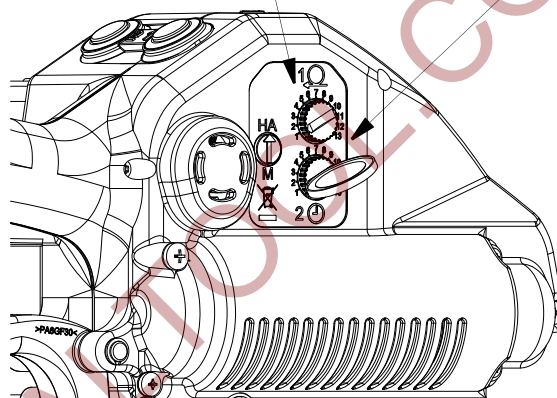

The adjustment knobs can be easily turned with a coin.

6.2.2 Adjusting the welding time

Depending on the size and quality of the strap, different welding times are required.

The welding time can be adjusted at the lower adjusting knob.

Turning clockwise increases,
 turning counter clockwise decreases the welding time.

6.2.3 Choose operation mode

There are 2 operation modes possible.

1. Manual

In this operation mode is the tensioning as well as the welding of the strap started by the operator.

2. Semi-Automatic

In this operation mode the welding of the strap is automatically started as soon as the preselected tension has been reached.

The choice of the operation mode can be made with the adjustment screw for operation mode.

Operation mode Manual	Operation mode Semi-Automatic
<p>Turn adjustment screw with a screw driver in the desired position.</p>	



6.3 Feeding the strap around the package

- The strapping is fed around the package as illustrated.

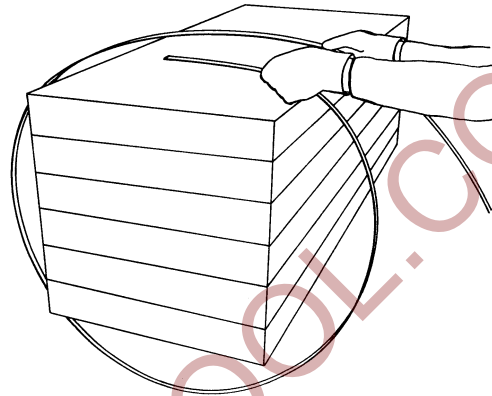

Warning! The plastic strap which will be welded must be free from oil, grease and other dirt. Dirty plastic straps can't be welded correct!

6.4 Inserting the strap

- Pull up the handle lever firmly with your right hand.
- Insert the two straps well aligned on each other into the strap guide using your left hand. The lower strap end must slightly protrude the end of the base plate.
- Release the handle lever.

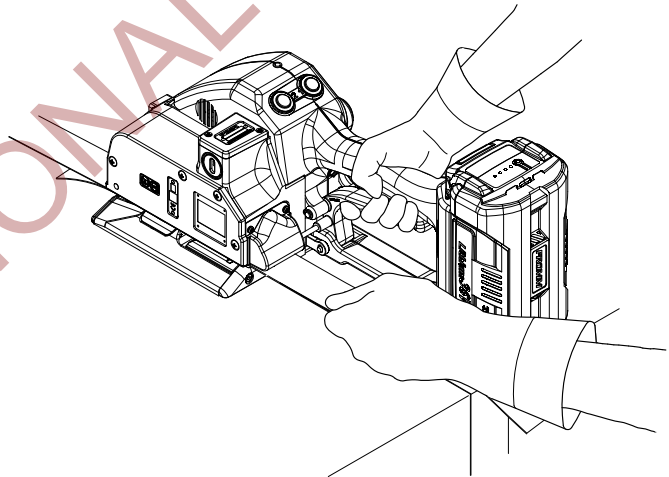

6.5 Tensioning the strap, Operation mode Manual

- Press down the tension button and then release it again after the desired strap tension has been reached.

The tensioning operation can be interrupted and restarted at any time.

During tensioning the LED lights green.

After automatic cut off of the tensioning force it can be tensioned again not before 8 seconds.

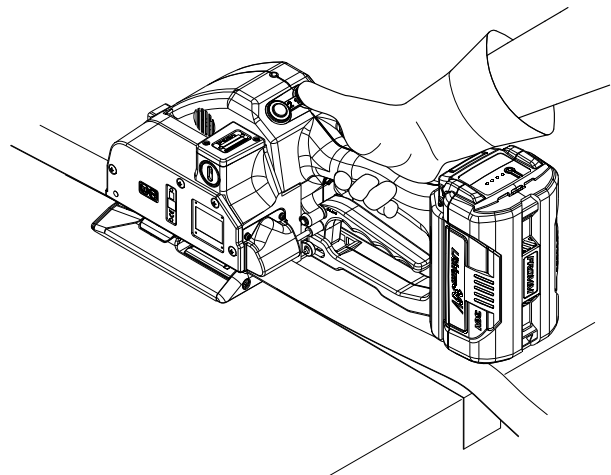

6.6 Sealing the straps, Operation mode Manual

- Press and release immediately the sealing button.

The plastic strap is welded and cut off from the rest of the strap.

During the welding the LED lights green.

After elapsing of the adjusted welding time (see 6.2.2) the cooling time begins (LED lights yellow). During that time the tool must not be removed from the strap.

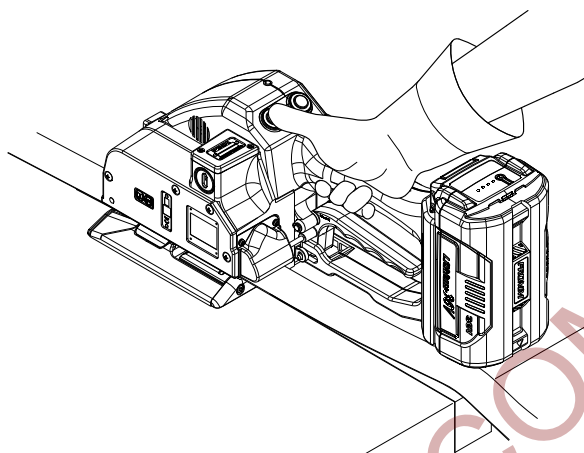

6.7 Tensioning and sealing the strap Operation mode Semi-Automatic

- Push tension button until the adjusted tension force is reached.

During tensioning the LED lights green.

The tensioning operation can be interrupted and restarted at any time.

After reaching the adjusted strap tension the sealing cycle is initiated automatically (LED lights blue). Welding gripper is lowered, the welding starts (LED lights green).

- Release the tension button after the sealing process has been started.

The plastic strap is welded and cut off from the rest of the strap. After elapsing of the adjusted welding time (see 6.2.2) the cooling time begins (LED lights yellow).

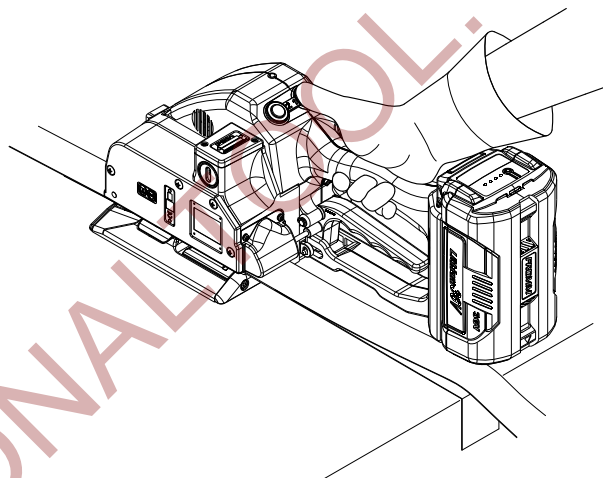

The tool must not be removed from the strap as long as the cooling time is not finished. Disregard of this regulation is causing insufficient seal efficiencies, which can cause severe injuries.

6.8 Removing the tool

After the cooling time is elapsed an acoustic signal happens and the LED lights green again. The sealing process is finished.

- Pull up the handle lever,
- pull the tool right and off the strapping.

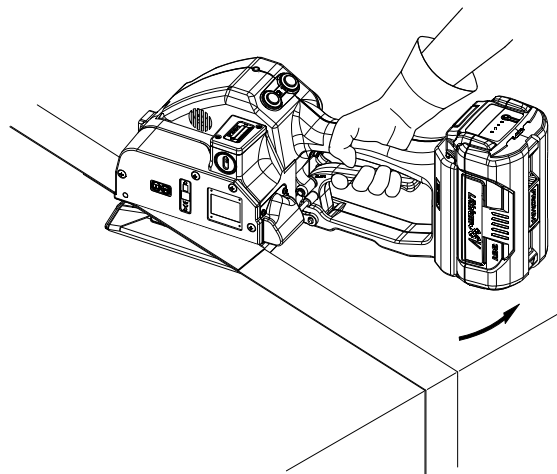

6.9 Seal - Control

A regular control of the seal is necessary. The seal can be examined visually. Make a seal, peel it apart and examine it as follows:



Correct seal

The seal must be completely welded over the whole width of the strap on a length of ca. 25 mm. Minor quantities of fused plastic may overflow on sides.



Welding time too short

The plastic strap is not welded over the whole width of the strap. The seal efficiency is insufficient. Warning! Straps with insufficient seal strength must be removed from the package! Adjust the welding time (see 6.2.2).



Welding time too long

If the welding time is too long the straps are overheated. The fused plastic overflows on both sides of the straps. The seal efficiency is affected. Warning! Straps with insufficient seal strength must be removed from the package! Adjust the welding time (see 6.2.2).

7 CHART OF TYPES P331 M/HA

Item No.	Model	Strap width	Strap thickness
43.0274	P331/19/0.80-1.19/7.0	19.0 mm / 3/4"	0.80 - 1.19 mm / .031" - .046"
43.0276	P331/19/1.20-1.53/7.0	19.0 mm / 3/4"	1.20 - 1.53 mm / .047" - .060"
43.0282	P331/25/0.60-0.79/7.0	25.0 mm / 1"	0.60 - 0.79 mm / .023" - .030"
43.0284	P331/25/0.80-1.19/7.0	25.0 mm / 1"	0.80 - 1.19 mm / .031" - .046"
43.0286	P331/25/1.20-1.35/7.0	25.0 mm / 1"	1.20 - 1.35 mm / .047" - .053"
43.0292	P331/32/0.60-0.79/7.0	32.0 mm / 1 1/4"	0.60 - 0.79 mm / .023" - .030"
43.0294	P331/32/0.80-1.19/7.0	32.0 mm / 1 1/4"	0.80 - 1.19 mm / .031" - .046"
43.0296	P331/32/1.20-1.35/7.0	32.0 mm / 1 1/4"	1.20 - 1.35 mm / .047" - .053"

8 ELECTRIC SCHEMATIC ELS.1084

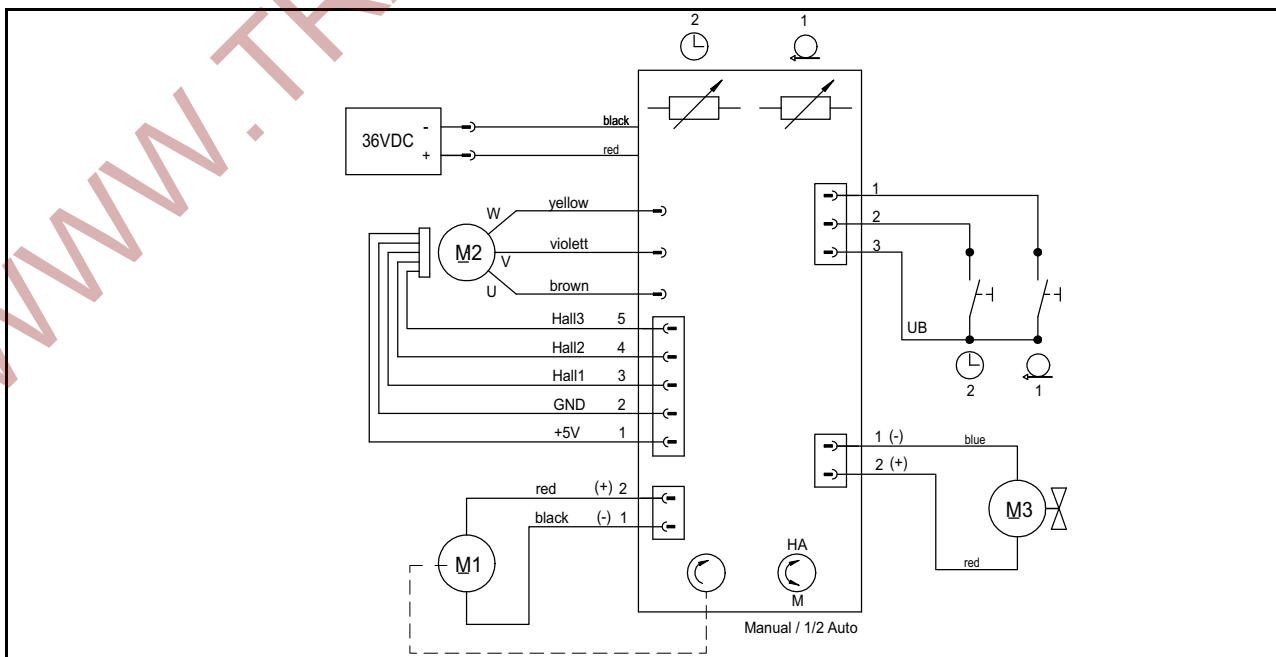

9 EXCHANGE OF WEARING PARTS



Remove always the battery from the tool before starting maintenance works.

9.1 Exchange of tensioning wheel and grippers

Disassembling

- Unscrew cover P33.2143 and remove it;
- Unscrew end cover P35.0226 and remove it;
- Raise tension wheel by lifting the handle lever P33.2117;
- Remove the tensioning wheel together with the bearing N31.1148 from the tool;
- Unscrew the holder P35.4184 and remove it from the body;
- Remove the grippers from the body.

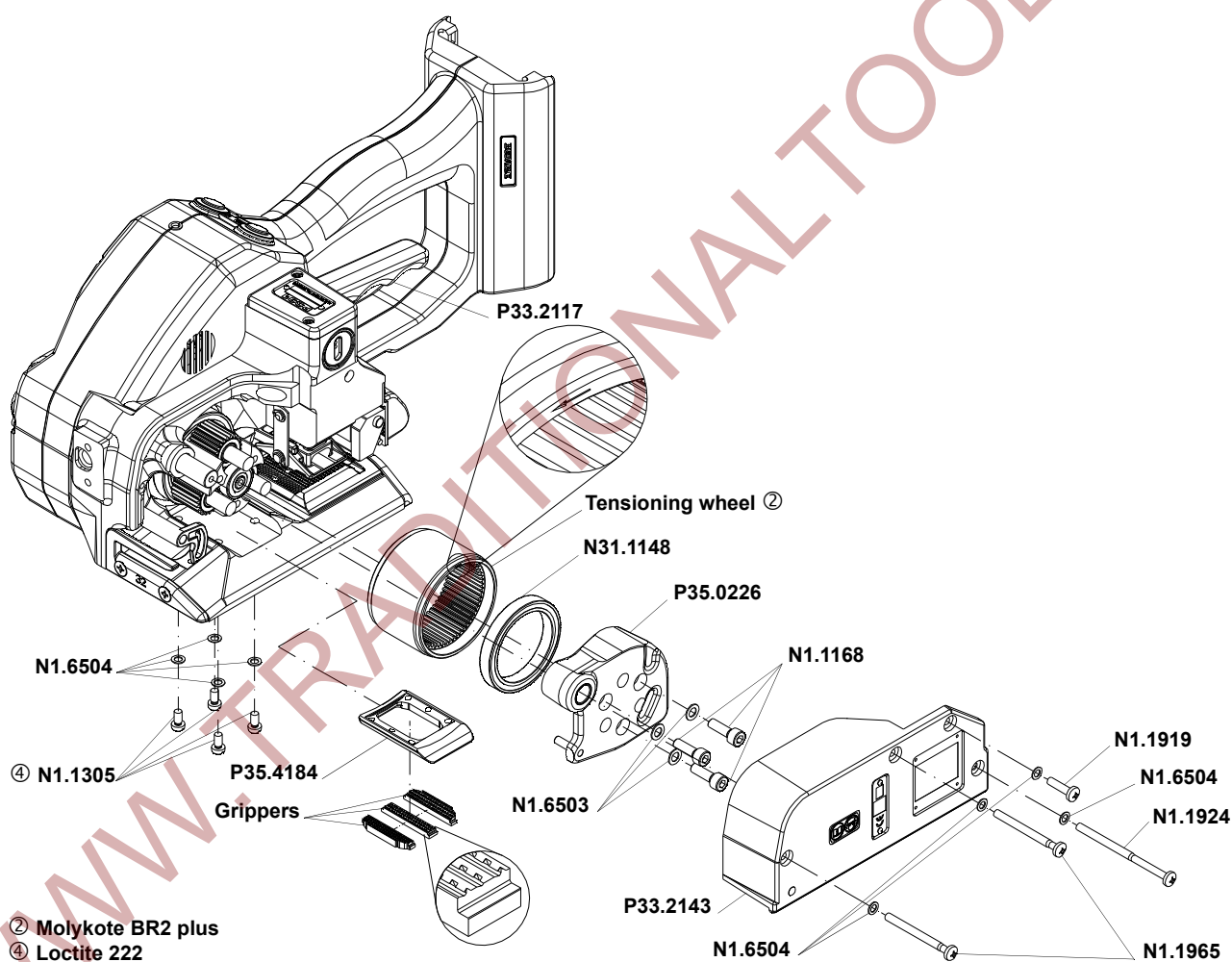

Assembling in opposite order.

Assembly advise

- Lubricate the internal tooting of the tensioning wheel with Molykote BR2 plus.
- Observe the position of the tensioning wheel. The direction of rotation of the tensioning wheel is marked at the front of the tensioning wheel (see drawing).
- Observe the position of the grippers (see drawing).
- Safe the screws N1.1305 with Loctite 222.

9.2 Exchange of cutter, welding stop gripper and welding gripper

Disassembling

- Unscrew motor housing and remove it;
- Unscrew cover P33.2143 and remove it;
- Unscrew end cover P35.0226 and remove it;
- Lift tension gear; pull off tensioning wheel together with bearing N31.1148 from the body.
- Remove cover P35.4213;
- **Don't** loosen screw N1.1553 at the coupler P35.0227.
- Disassemble the security ring N2.1121 from the coupler, remove the coupler;
- Pull out the centering sleeve P33.2142 from the guide case, disassemble the guide case;
- Remove the cutter P35.4198 together with the pressure spring and the guide from the driving pin P35.4110;
- Take pressure spring N21.5211 together with the spring guide P35.4199 from the cutter.
- Disassemble strap guide plate P35.4105;
- Disassemble the screws N1.1305, lift slightly the welding stop gripper P35.4104 and the steel insert and remove them from the tool;
- Push the steel insert without welding stop gripper under the welding gripper P35.4107 until it touches the parallel pin N2.2110;
- Turn welding gripper down, in case the welding gripper does not sit on the steel insert, put a piece of plastic strap underneath the steel insert;
- Disassemble the safety ring N2.1118 from the bolt P35.4210, remove the bolt from the welding gripper;
- Turn welding gripper up;
- Pull out the steel insert with care to right under the welding gripper;
- Lift the rocker P35.4106 behind the welding gripper with a screw driver, remove the welding gripper together with the ball cage P32.1027 and the balls N3.1702 from the tool;
- Lower the rocker, remove the thrust piece P32.1029 from the tool.

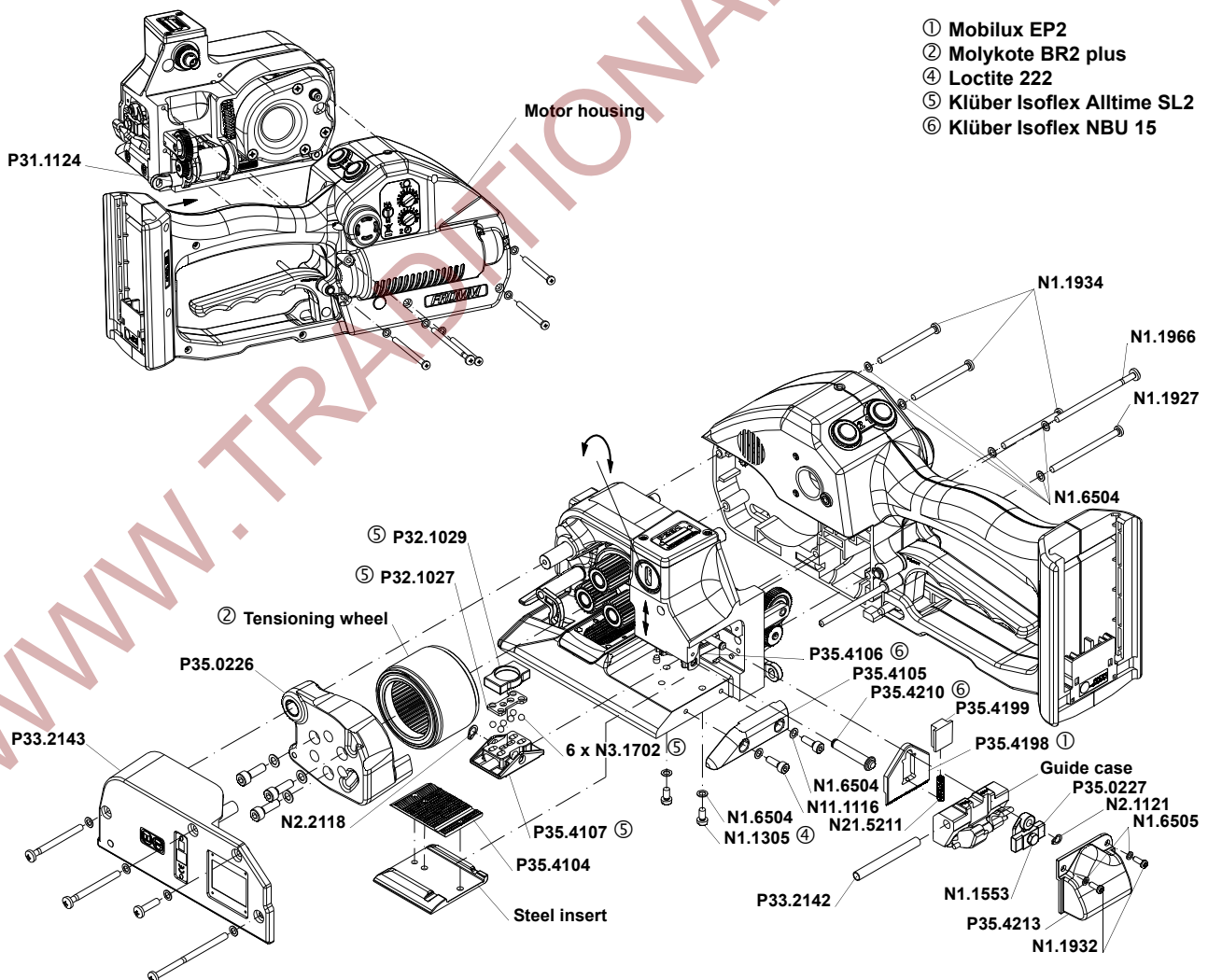

Assembling in opposite order.

Assembly advise

- During assembling move the strap guide plate P35.4105 downwards against the holding gripper.
- Before mounting the motor housing check the proper seat of the tube P31.1124, it must be pushed in completely (see drawing).
- Pay attention to the fitting position of the cutter (see drawing).
- Safe the screws N1.1305 with Loctite 222.
- Lubricate the rocker and the bolt P35.4210 in the area of the welding gripper with Klüber Isoflex NBU 15.
- Lubricate the balls, ball cage and the running surface of the balls on the welding gripper with Klüber Isoflex Alltime SL2.
- Lubricate the cutter and the driver with Mobilux EP2.

9.3 Adjustment of the coupler

The coupler is adjusted in our works.

In case of replacing the seesaw lever, the coupler or the lever body, the coupler has to be readjusted.

Procedure as follows:

The battery is removed from the tool.

The coupler is fitted into the tool.

- Loosen screw N1.1553.
- Displace thrust piece, so that it touches the two seesaw levers without moving them.
- Re-tighten screw N1.1553.

Control:

The thrust piece must touch the seesaw levers (X1).

Both guide pins must sit on the welding stop gripper (X2).

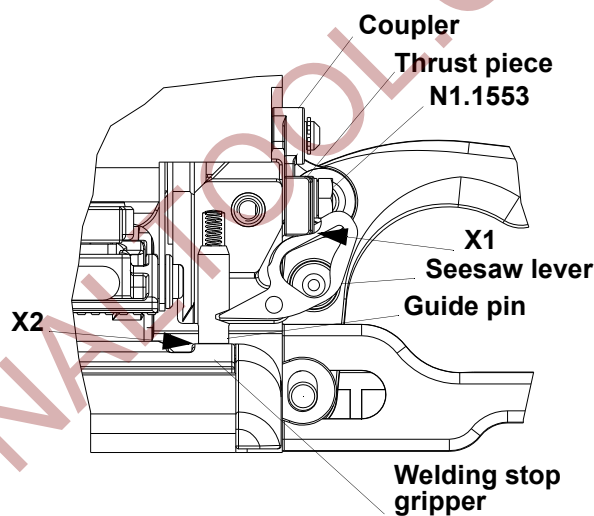

10 CLEANING

Clean strap gripping parts from strap abrasion regularly using compressed air.

Thus also the cover can be removed and with a suitable air gun air been blown on the welding elements.

Do not use any mechanical tool for cleaning.

When cleaning the surface of the tool do not use water or aggressive solvents!

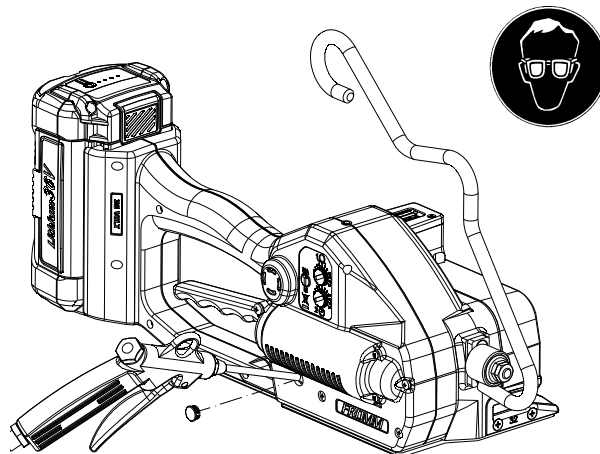

11 SERVICE

Servicing and repair work must only be carried out by authorized service centres.

If the tool breaks down or does no longer operate do not disassemble it. Send it fully assembled to the local service centre (see name and address on the rear page of this manual). Use original packing.

In order to prevent damages to the motor shaft the two needle free wheeling N3.4509 have to be replaced after maximum 80 000 strapping cycles.

The battery powered plastic strapping tool P331 is a high performance tool. We strongly recommend you to have it serviced by an authorized service shop after 12 months at the latest if used one shift per day. If used two or more shifts per day the tool has to be serviced after a shorter period of time.

12 TRANSPORT

Lithium-ion batteries are subject to the Dangerous Goods Legislation requirements. The user can transport the batteries by road without further requirements.

When being transported by third parties (e.g.: air transport or forwarding agency), special requirements on packaging and labelling must be observed.

For preparation of the item being shipped, consulting an expert for hazardous material is required.

Dispatch batteries only when the housing is undamaged.

Tape or mask off open contacts and pack up the battery in such a manner that it cannot move around in the packaging.

Please also observe possibly more detailed national regulations.

13 DISPOSAL

The machine, rechargeable batteries, accessories and packaging should be sorted for environmental- friendly recycling.

Do not dispose of power tools and batteries/rechargeable batteries into household waste!

Only for EC countries:

According to the European Guideline 2002/96/EC, power tools that are no longer usable, and according to the European Guideline 2006/66/EC, defective or used battery packs/batteries, must be collected separately and disposed of in an environmentally correct manner.

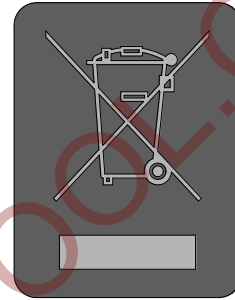

14 WARRANTY CONDITIONS AND LIABILITY

FROMM Holding AG warrants all its strapping tools and machine heads during a period of 12 months from the date sale.

The warranty includes all deficiencies clearly resulting from poor manufacturing or faulty materials. Damage claims as a result of production shutdowns and claims for damage to persons and to property resulting from warranty deficiencies cannot be asserted by the customer.

The warranty excludes:

- wearing parts (tensioning wheels, cutters, punches, dies, notching knives, grippers, batteries and motors),
- deficiencies resulting from improper installing, incorrect handling and maintaining the tool,
- deficiencies resulting from using the tool without or with defective security- and safety devices,
- disregard of directions in the operation manual,
- arbitrary modifications of the tool,
- deficient control of wearing parts,
- deficient repair works of the tool,
- use of consumable products not recommended by FROMM Holding AG.

We reserve the right to modify the product at any time in order to improve its quality.

15 APPROPRIATE USE

The tool model P331 has been designed to strap packages with plastic strapping exclusively.

For the use in hazardous areas the tool is not suitable.

The warranty / liability excludes:

- non appropriate use of the tool,
- disregard of directions in the operation manual,
- disregard of control- and maintenance instructions.

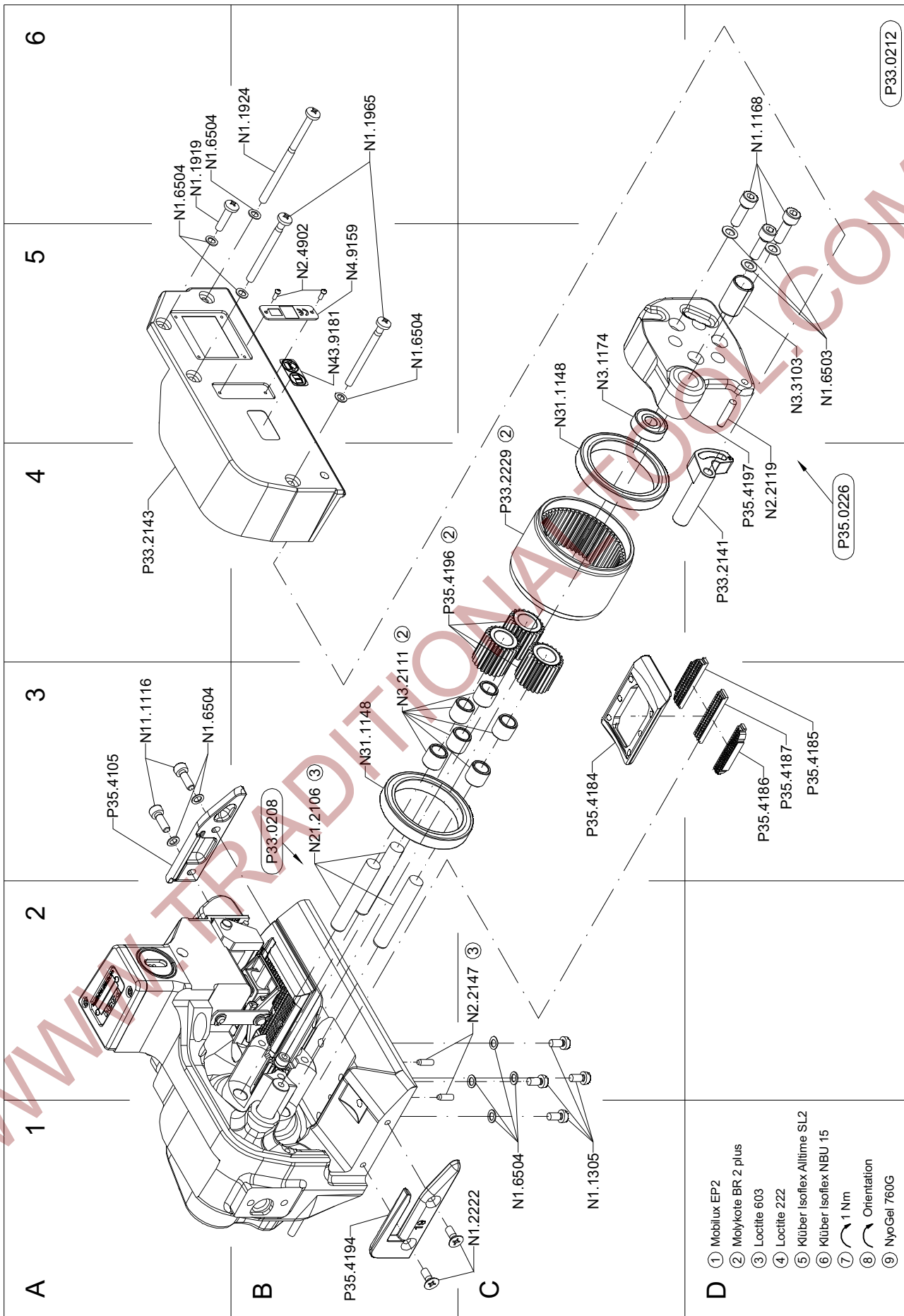

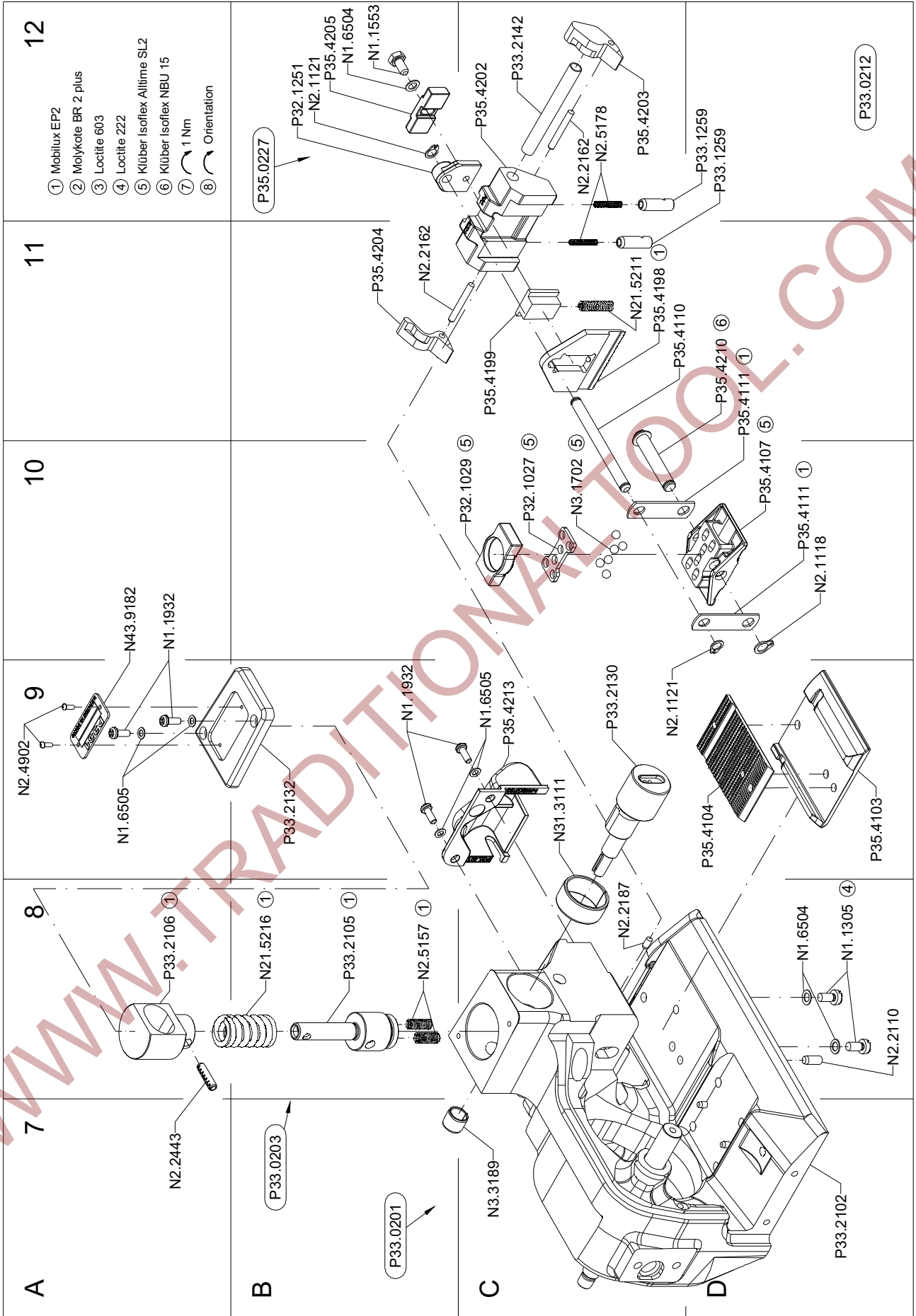

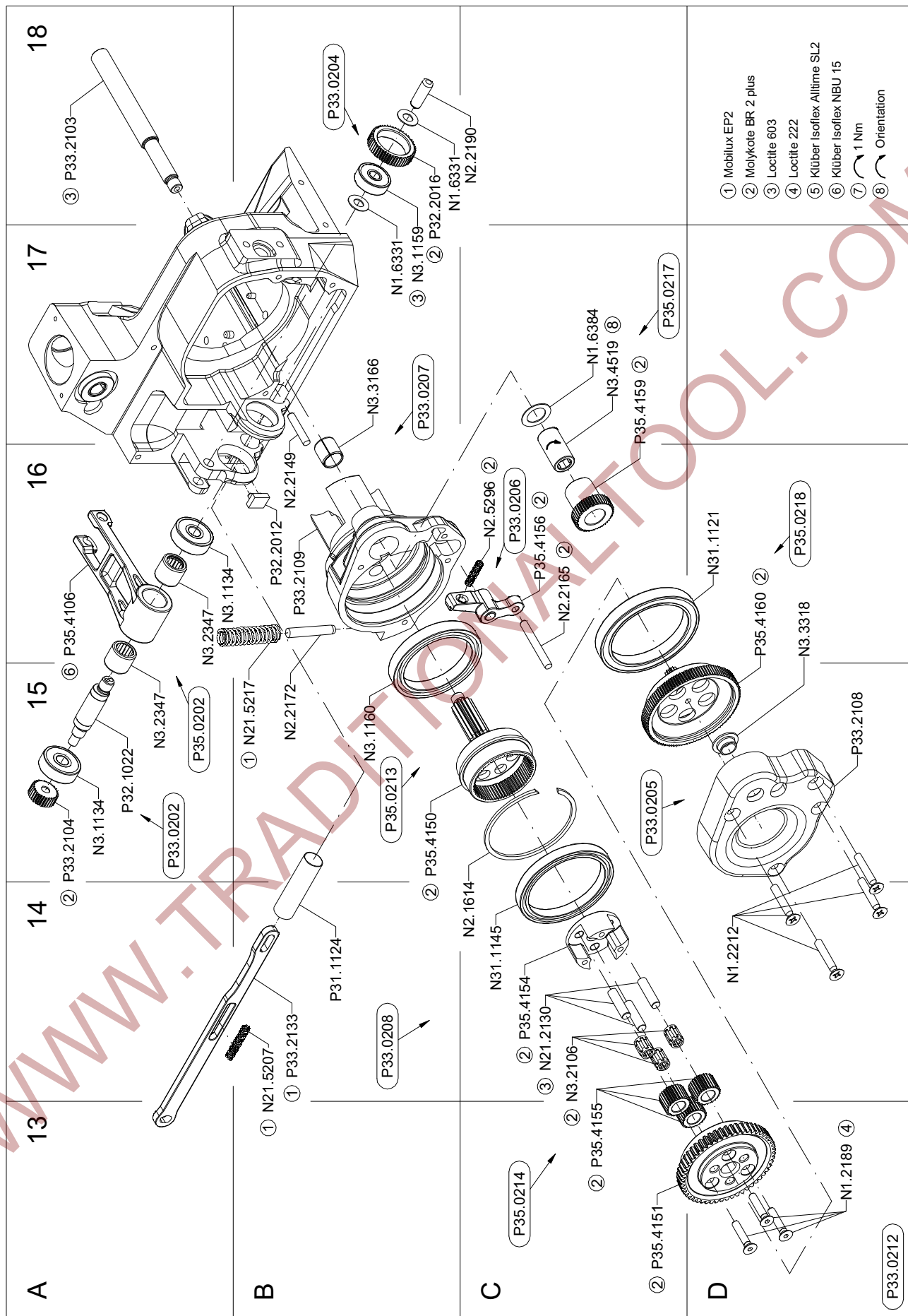

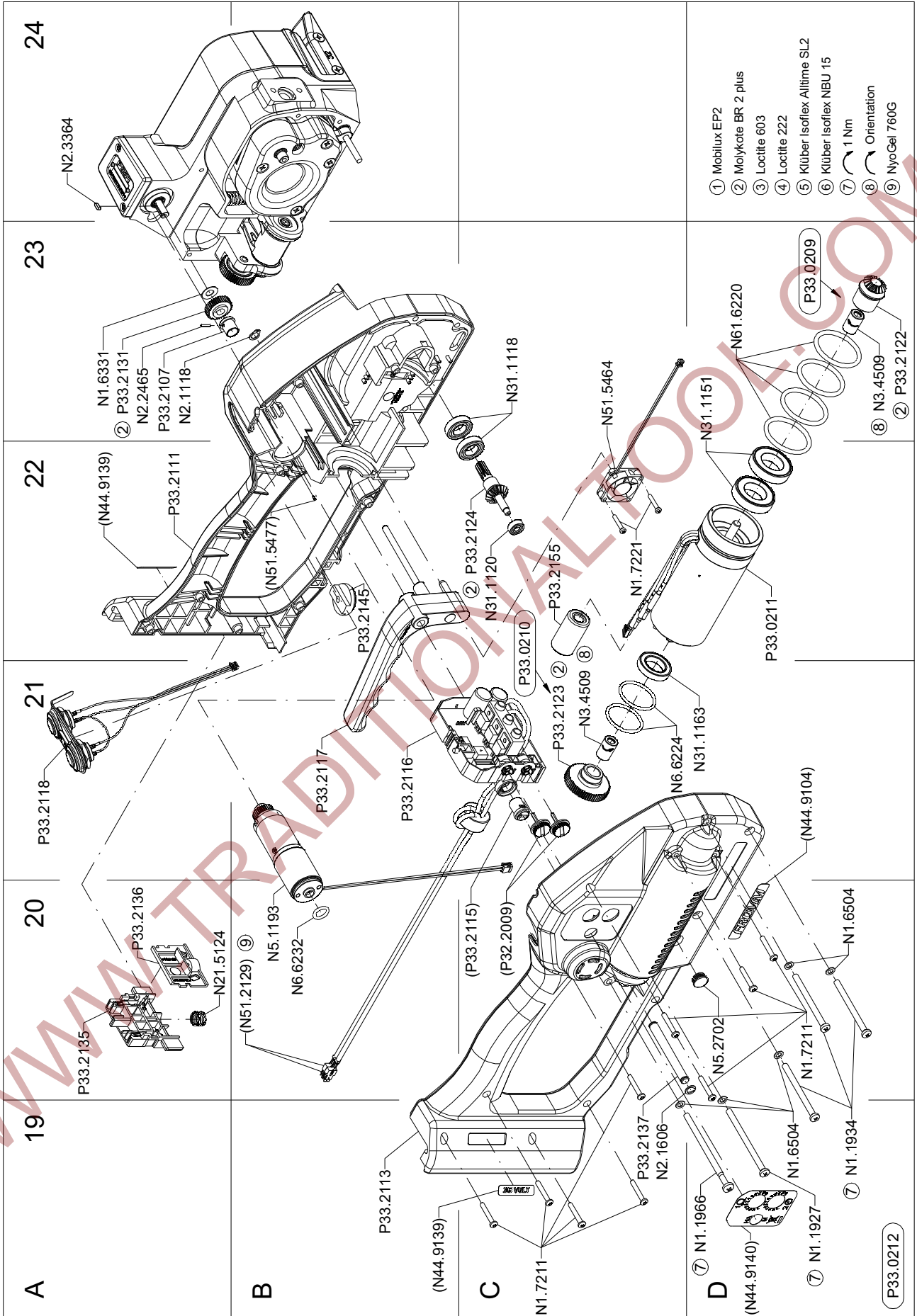

- ① Mobilux EP2
- ② Molykote BR 2 plus
- ③ Loctite 603
- ④ Loctite 222
- ⑤ Klüber Isoflex Alltime SL2
- ⑥ Klüber Isoflex NBU 15
- ⑦ 1 Nm
- ⑧ Orientation
- ⑨ NyoGel 760G

16 SPARE PARTS LIST 43.0276.01

43.0276.01	P331/19/1.20-1.53/7.0		P331.0001.01			17.06.14
Item-No.		in group	Pcs.	Description	Dimension	Field
N1.1168			3	SCREW	M5 X 16	D6
N1.1305			6	SCREW	M4 X 7.8	C1+
N1.1553		P35.0227	1	HEXAGON SCREW	M4 X 8	B12
N1.1919			1	SCREW	M4 X 16	A6
N1.1924			1	SCREW	M4 X 65	B6
N1.1927		P33.0212	1	FLAT HEAD SCREW	M4 X 60	D19
N1.1932			2	FLAT HEAD SCREW	M3 X 8	A10
N1.1932		P33.0212	2	FLAT HEAD SCREW	M3 X 8	B9
N1.1934		P33.0212	3	FLAT HEAD SCREW	M4 X 50	D19
N1.1965			2	SCREW	M4 X 45	B6
N1.1966		P33.0212	1	SCREW	M4 X 70	D19
N1.2189		P35.0214	3	COUNTERSUNK SCREW	M4 X 20	D13
N1.2212		P33.0208	4	COUNTERSUNK SCREW	M4 X 25	D14
N1.2222			2	COUNTERSUNK SCREW	M4 X 10	C1
N1.6331		P33.0212	3	SPACER WASHER	6 X 12 X 0.5	A23+
N1.6384		P33.0208	1	SPACER WASHER	11 X 17 X 0.5	C17
N1.6503			3	SAFETY WASHER	M5	D5
N1.6504			12	SAFETY WASHER	M4	C1+
N1.6504		P33.0212	5	SAFETY WASHER	M4	D19+
N1.6504		P35.0227	1	SAFETY WASHER	M4	B12
N1.6505			2	SAFETY WASHER	M3	A9
N1.6505		P33.0212	2	SAFETY WASHER	M3	C9
N1.7211		P33.0212	9	PT-SCREW	3 X 20	C19+
N1.7221		P33.0212	2	PT-SCREW	2.5 X 14	C22
N11.1116			2	SCREW	M4 X 12	A3
N2.1118		P33.0212	2	SECURITY RING	6	A23+
N2.1121			1	SECURITY RING	5	B12
N2.1121		P33.0212	1	SECURITY RING	5	C9
N2.1606		P33.0212	1	SPRING RING	SW6	C19
N2.1614		P33.0208	1	SPRING RING		C14
N2.2110		P33.0201	1	PARALLEL PIN	4 m6 X 10	D8
N2.2119		P35.0226	1	PARALLEL PIN	4 m6 X 18	D4
N2.2147		P33.0201	2	PARALLEL PIN	3 m6 X 10	C2
N2.2149		P33.0212	1	PARALLEL PIN	4 h6 X 22	B16
N2.2162			2	PARALLEL PIN	3 m6 X 24	B11+
N2.2165		P33.0206	1	PARALLEL PIN	4 m6 X 34	C16
N2.2172		P33.0207	1	PARALLEL PIN	5 m6 X 30	B15
N2.2187		P33.0201	1	PARALLEL PIN	3 m6 X 6	C8
N2.2190		P33.0212	1	PARALLEL PIN	6 h6 X 18	C18
N2.2443		P33.0203	1	DOWEL PIN	4 X 15	A7
N2.2465		P33.0212	1	DOWEL PIN	1.5 X 8	A23
N2.3364		P33.0212	1	FEATHER KEY	2 X 2 X 6	A24
N2.4902			4	HAMMER HEAD BOLT	1.85 X 4.76	B5+
N2.5157		P33.0212	2	PRESSURE SPRING	0.6 X 4.8 X 20/15.5	B8
N2.5178			2	PRESSURE SPRING	0.32X2.82X20.5/20.5	C12
N2.5296		P33.0208	1	PRESSURE SPRING	0.5 X 4 X 24/16.5	C16
N21.2106		P33.0207	3	PARALLEL PIN	8 h6 X 50	B3
N21.2130		P35.0214	3	PARALLEL PIN	5 h6 X 20	C14
N21.5124		P33.0212	1	PRESSURE SPRING	0.9 X 10 X 15/5.5	A20
N21.5207		P33.0212	1	PRESSURE SPRING	0.5 X 4.5 X 31/20.5	B14
N21.5211			1	PRESSURE SPRING	0.75 X 4.5 X 24/15.5	C11

[] = Group

* = Wearing parts

43.0276.01	P331/19/1.20-1.53/7.0		P331.0001.01			17.06.14
Item-No.		in group	Pcs.	Description	Dimension	Field
N21.5216		P33.0203	1	PRESSURE SPRING	2.8 X 15 X 34.5/7.5	B8
N21.5217		P33.0212	1	PRESSURE SPRING	1.25 X 9.5 X 46.5/15.5	B15
N3.1134		P33.0202	1	BALL BEARING	7 X 22 X7	A15
N3.1134		P33.0212	1	BALL BEARING	7 X 22 X7	A16
N3.1159		P33.0204	1	BALL BEARING	6 X 19 X 6	B17
N3.1160		P35.0213	1	BALL BEARING	40 X 52 X 7	B15
N3.1174			1	BALL BEARING	7 X 19 X 6	C5
N3.1702		P33.0212	6	BALL	4 MM	C10
N3.2106		P35.0214	3	NEEDLE CAGE	K 5 X 8 X 10 TN	C14
N3.2111			6	NEEDLE CAGE	K 8 X 11 X 10 TV	B3
N3.2347		P35.0202	2	NEEDLE BUSH	10 X 14 X 12	A15+
N3.3103		P35.0226	1	SLIDE-BEARING	10 X 12 X 20	D5
N3.3166		P33.0207	1	SLIDE-BEARING	10 X 12 X 12	B17
N3.3189		P33.0201	1	SLIDE-BEARING	8 X 10 X 8	C7
N3.3318		P33.0205	1	SLIDE-BEARING	8 X 10 X 4	D16
N3.4509		P33.0209	1	NEEDLE FREE WHEELING	6 X 10 X 15	D23
N3.4509		P33.0210	1	NEEDLE FREE WHEELING	6 X 10 X 15	C21
N3.4519		P35.0217	1	FREE-WHEELING	8 X 12 X 22	C17
N31.1118		P33.0212	2	BALL BEARING	10 X 19 X 5	C23
N31.1120		P33.0212	1	BALL BEARING	4 X 11 X 4	C22
N31.1121		P35.0218	1	BALL BEARING	45 X 58 X 7	D16
N31.1145		P35.0214	1	BALL BEARING	45 X 55 X 6	C14
N31.1148			2	BALL BEARING	40 X 52 X 7	B3+
N31.1151		P33.0212	2	BALL BEARING	17 X 30 X 7	D23
N31.1163		P33.0210	1	BALL BEARING	15 X 24 X 5	D21
N31.3111		P33.0201	1	SLIDE-BEARING	20 X 23 X 10	C9
N4.9159			1	LABEL	<<CE>>	B5
N43.9181			1	ADHESIVE LABEL	20 X 10 X 0.1	B5
N43.9182			1	TYPE PLATE	<<P331>>	A10
N44.9104		P33.2113	1	ADHESIVE LABEL	<<FROMM>>	D21
N44.9139		P33.2111	1	ADHESIVE LABEL	36V	A22
N44.9139		P33.2113	1	ADHESIVE LABEL	36V	B19
N44.9140		P33.2113	1	ADHESIVE LABEL		D19
N5.1193	*	P33.0212	1	GEAR MOTOR		B20
N5.2702		P33.0212	1	COVER		D20
N51.2129		P33.2008	1	CONTACT PLUG		B20
N51.2129		P33.2010	1	CONTACT PLUG		B20
N51.5464		P33.0212	1	FAN		C23
N51.5477		P33.2111	1	SPRING PIN		B22
N6.6224		P33.0212	2	O-RING	24 X 2	C21
N6.6232		P33.0212	1	O-RING	8 X 2	B20
N61.6220		P33.0212	4	O-RING	29.5 X 3	D23
P31.1124		P33.0201	1	TUBE		B14
P32.1022		P33.0202	1	WELDING EXCENTRIC		A15
P32.1027		P33.0212	1	BALL CAGE		C10
P32.1029		P33.0212	1	THRUST PIECE		C10
P32.1251		P35.0227	1	PUSHER		B12
P32.2009		P33.2116	2	TURNING BUTTON		C20
P32.2012		P33.0212	1	GUIDE		B16
P32.2016		P33.0204	1	GEAR WHEEL		B18
[P33.0201]		P33.0212	1	BODY		B7
[P33.0202]		P33.0212	1	WELDING EXCENTRIC		A15
[P33.0203]		P33.0212	1	SPRING BOLT		B7

[] = Group

* = Wearing parts

43.0276.01	P331/19/1.20-1.53/7.0		P331.0001.01		17.06.14	
Item-No.		in group	Pcs.	Description	Dimension	Field
[P33.0204]		P33.0212	1	GEAR WHEEL		B18
[P33.0205]		P33.0208	1	GEARING COVER		C15
[P33.0206]		P33.0208	1	LEVER		C16
[P33.0207]		P33.0208	1	GEAR BODY		B17
[P33.0208]		P33.0212	1	GEAR		B14+
[P33.0209]		P33.0212	1	CONICAL GEAR WHEEL		D23
[P33.0210]		P33.0212	1	GEAR WHEEL		C22
P33.0211	*	P33.0212	1	MOTOR		D22
[P33.0212]			1	BASE MODEL		D6+
P33.1259			2	GUIDE PIN		D12
P33.2102		P33.0201	1	BODY		D7
P33.2103		P33.0201	1	BOLT		A18
P33.2104		P33.0202	1	PINION		A15
P33.2105		P33.0203	1	SPRING BOLT		B8
P33.2106		P33.0203	1	SPRING SLIDE		A8
P33.2107		P33.0212	1	RETAINER		A23
P33.2108		P33.0205	1	GEARING COVER		D15
P33.2109		P33.0207	1	GEAR BODY		B16
[P33.2111]		P33.0212	1	MOTOR HOUSING		A22
[P33.2113]		P33.0212	1	MOTOR HOUSING		B19
P33.2115		P33.2116	1	TURNING BUTTON		C20
[P33.2116]		P33.0212	1	CIRCUIT BOARD	36V	B21
P33.2117		P33.0212	1	HANDLE LEVER		B21
P33.2118		P33.0212	1	TOUCH CONTACT-SWITCH		A21
P33.2122		P33.0209	1	CONICAL GEAR WHEEL		D23
P33.2123		P33.0210	1	GEAR WHEEL		C21
P33.2124		P33.0212	1	CONICAL GEAR WHEEL		C22
P33.2130		P33.0212	1	ECCENTRIC SHAFT		C9
P33.2131		P33.0212	1	GEAR WHEEL		A23
P33.2132		P33.0212	1	COVER		B9
P33.2133		P33.0212	1	PUSHER		B14
P33.2135		P33.0212	1	INSERTATION PART		A20
P33.2136		P33.0212	1	COVER		A20
P33.2137		P33.0212	1	HANDLE SHAFT		C19
P33.2141			1	STRAP GUIDE		D4
P33.2142			1	CENTERING SLEEVE		C12
P33.2143			1	COVER		A4
P33.2145		P33.0212	1	DISK		B22
P33.2155		P33.0212	1	DOWEL		C22
P33.2229	*		1	TENSIONING WHEEL		C4
[P35.0202]		P33.0212	1	ROCKER		A15
[P35.0213]		P33.0208	1	GEAR WHEEL		B15
[P35.0214]		P33.0208	1	WHEEL		C13
[P35.0217]		P33.0208	1	RATCHET WHEEL		C17
[P35.0218]		P33.0208	1	GEAR WHEEL		D16
[P35.0226]			1	END COVER		D4
[P35.0227]			1	PUSHER		B12
P35.4103			1	STEEL INSERT		D9
P35.4104	*		1	WELDING STOP GRIPPER		D9
P35.4105			1	STRAP GUIDE PLATE		A3
P35.4106		P35.0202	1	ROCKER		A16
P35.4107	*	P33.0212	1	WELDING GRIPPER		D10
P35.4110		P33.0212	1	DRIVING PIN		C11

[] = Group

* = Wearing parts

43.0276.01	P331/19/1.20-1.53/7.0		P331.0001.01			17.06.14
Item-No.		in group	Pcs.	Description	Dimension	Field
P35.4111		P33.0212	2	DRIVER		D10+
P35.4150		P35.0213	1	GEAR WHEEL		B15
P35.4151		P35.0214	1	GEAR WHEEL		C13
P35.4154		P35.0214	1	PLANET SHAFT		C14
P35.4155		P35.0214	3	PINION		C13
P35.4156		P33.0206	1	LEVER		C16
P35.4159		P35.0217	1	GEAR WHEEL		C17
P35.4160		P35.0218	1	GEAR WHEEL		D16
P35.4184			1	HOLDER		C3
P35.4185	*		1	GRIPPER		D3
P35.4186	*		1	GRIPPER		D3
P35.4187	*		1	GRIPPER		D3
P35.4194			1	STRAP STOP		B1
P35.4196			3	PINION		B4
P35.4197		P35.0226	1	END COVER		D4
P35.4198	*		1	CUTTER		C11
P35.4199			1	GUIDE		C11
P35.4202			1	GUIDE CASE		C12
P35.4203			1	SEESAW LEVER		C12
P35.4204			1	SEESAW LEVER		B11
P35.4205		P35.0227	1	THRUST PIECE		B12
P35.4210		P33.0212	1	BOLT		D11
P35.4213			1	COVER		C9

[] = Group

* = Wearing parts