

## FROMM

OPERATION MANUAL / SPARE PARTS LIST

### BATTERY - POWERED PLASTIC STRAPPING TOOL MODEL P322

43.2124.01

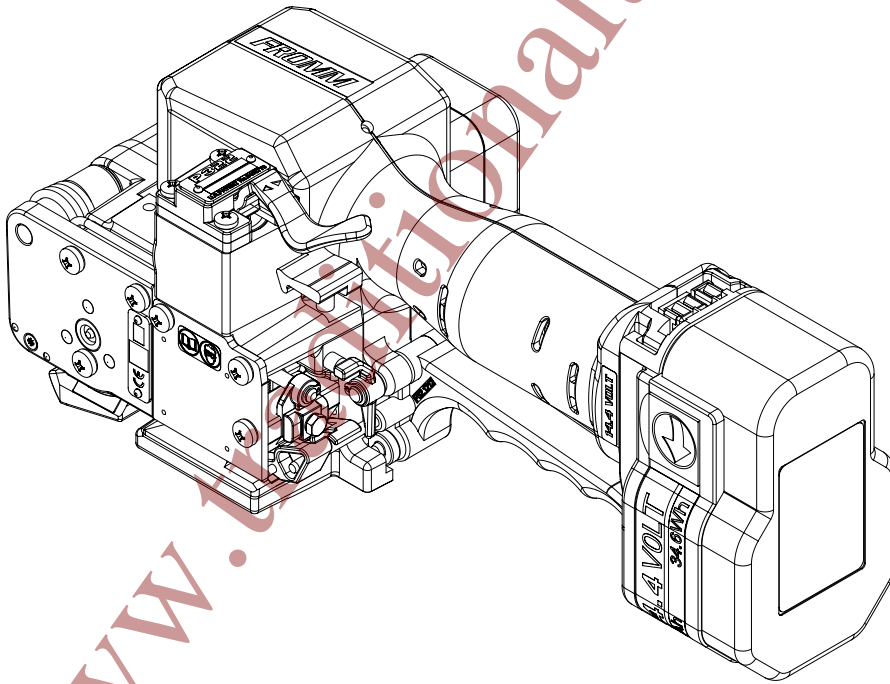

#### CE Declaration of conformity

We declare that the machine P322  
is in conformity with the following standard or  
standardised documents:  
98/37/EEC

FROMM Holding AG  
Hinterbergstrasse 26  
CH - 6330 Cham  
12.08 2005

R.Fromm  
Director



	<b>INDEX</b>	<b>PAGE</b>
<b>1</b>	<b>SAFETY INSTRUCTIONS</b>	<b>3</b>
<b>2</b>	<b>TECHNICAL DATA</b>	<b>4</b>
<b>3</b>	<b>ACCESSORIES</b>	<b>5</b>
3.1	Battery . . . . .	5
3.2	Battery - chargers . . . . .	5
3.3	Wearing plate . . . . .	6
3.4	Suspension . . . . .	6
3.5	Turning button kit. . . . .	7
<b>4</b>	<b>OPERATING ELEMENTS</b>	<b>8</b>
<b>5</b>	<b>OPERATION</b>	<b>8</b>
5.1	Installation . . . . .	8
5.2	Adjustments. . . . .	9
5.2.1	Preselecting of strap tension and tensioning speed . . . . .	9
5.2.2	Adjusting the welding time. . . . .	9
5.3	Feeding the strap around the package . . . . .	9
5.4	Inserting the strap . . . . .	10
5.5	Tensioning the strap . . . . .	10
5.6	Sealing of the joint . . . . .	11
5.7	Removing the tool . . . . .	11
5.8	Seal - Control. . . . .	11
<b>6</b>	<b>CHART OF TYPES</b>	<b>12</b>
<b>7</b>	<b>ELECTRIC SCHEMATIC</b>	<b>12</b>
<b>8</b>	<b>EXCHANGE OF WEARING PARTS</b>	<b>13</b>
8.1	Exchange of tensioning wheel and grippers . . . . .	13
8.2	Exchange of cutter, welding stop gripper and welding gripper . . . . .	14
8.3	Adjustment of the coupler P32.1250 . . . . .	15
<b>9</b>	<b>WARRANTY CONDITIONS AND LIABILITY</b>	<b>16</b>
<b>10</b>	<b>APPROPRIATE USE</b>	<b>16</b>
<b>11</b>	<b>SERVICE</b>	<b>16</b>
<b>12</b>	<b>CLEANING</b>	<b>16</b>
<b>13</b>	<b>SPARE PARTS LIST 43.2124.01</b>	<b>21</b>

# 1 SAFETY INSTRUCTIONS

Read these instructions carefully. Failure to follow these instructions can result in severe personal injury.

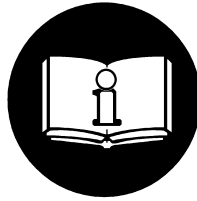

## Operation with battery

Environment protection:

- Do not dispose of used batteries in the household refuse, water or by burning them. FROMM distributors offer an environment friendly battery disposal service.

Danger of shortcircuit:

- Do not store batteries together with metal objects.
- Do not open batteries and store them only in dry and frost-proof rooms. The maximum ambient temperature is 50°C. Keep dry at all times.
- Never charge a damaged battery. Replace by a new one immediately.

## Eye injury hazard

Failure to wear safety glasses with side shields can result in severe eye injury or blindness. Always wear safety glasses with side shields which conform to ANSI Standard Z87.1.



## Operation

Tool must not be used by persons not properly trained in their use. Before tensioning strap, read and understand the tool operating instructions. Failure to follow the operating instructions or improper load positioning could result in strap breakage. Become familiar with your tool and keep fingers away from areas that can pinch or cut.

## Joints

You are fully responsible to review the joints made by your tool. Become familiar with the seal control and seal adjustment described in this operation manual. Misformed joints may not secure the load and could cause serious injury. Never handle or ship any load with improperly formed joints.

## Dispensing strap

Only dispense strap from a dispenser specifically designed for strap. Tuck strap end back into dispenser when not in use.

## Strap warnings

Never use strap as a means of pulling or lifting loads. Failure to follow these warnings can result in severe personal injury.

## Strap breakage hazard

Improper operation of the tool, excessive tensioning, using strap not recommended for this tool or sharp corners on the load can result in a sudden loss of strap tension or in strap breakage during tensioning, which could result in the following:

- A sudden loss of balance causing you to fall.
- Both tool and strap flying violently towards your face.

Note as follows:

- If the load corners are sharp, use edge protectors.
- Place the strap correctly around a properly positioned load.
- Positioning yourself in-line with the strap, during tensioning and sealing, can result in severe personal injury from flying strap or tool. When tensioning or sealing, position yourself to one side of the strap and keep all bystanders away.
- Use the correct strap quality, strap width, strap gauge and strap tensile strength recommended in this manual for your tool. Using strap not recommended for this tool can result in strap breakage during tensioning.

## Cutting tensioned strap

When cutting strapping, use the proper strapping cutter and keep other personnel and yourself at a safe distance from the strap. Always stand to side of the strap, away from the direction the loosened strap end will fly. Use only cutters designed for strap and never hammers, pliers, hacksaws, axes, etc.

## Fall hazard

Keep your working area tidy. Untidiness of your working area may cause a risk of injury. Maintaining improper footing and/or balance when operating the tool can cause you to fall. Before tensioning and especially in elevated areas, always establish good balance. Both feet should be securely placed on a flat, solid surface, especially when working in elevated areas. Do not use the tool when you are in an awkward position. Pay attention to the rules and regulations for preventions of accident which are valid for the work place.

## Tool hazards

A well maintained tool is a safe tool! Check tool regularly for broken or worn parts. Do not operate a tool with broken or worn parts. Never modify any tool. Modification can result in severe bodily injury.

---

## 2 TECHNICAL DATA

### Description of the tool

The tool model P322 has been designed to strap packages with plastic strapping. The plastic strapping is fed around the package manually or in combination with a strap feeder. The straps are inserted in the tool, automatically tensioned, sealed by friction welding and separated.

### Tool size with battery

Length: 335 mm / 13.2"

Width: 159 mm / 6.3"

Height: 126 mm / 5.0"

Weight: 4.4 kg / 9.7 lbs

### Sound information

The A-weighted equivalent continuous sound level at the work place of the machine operator is typical 81 dB (A).

This value was determined according to DIN 45 635 T3 (11.85).

### Vibration information

The weighted effective value of the acceleration typically amounts to less than 2,5m/s<sup>2</sup>.

This value was determined according to DIN EN 28 662 T1 (01.93).

### Strap material

Strap qualities: PET (Polyester) and PP (Polypropylene) plain or embossed.

**Use only plastic straps recommended by your sales shop (name and address on the rear of the operation manual).**

Strap dimensions: 10.0 - 16.0 mm / 3/8 - 5/8" x 0.4 - 1.05 mm / .016 - .041" (see chart of types).

**Use only plastic straps with the correct strap dimensions for your tool.**

### Strap tension

Tensioning force: Adjustable from 400 - max. 2000 N / 90 - max. 450 lbs.  
The maximum value depends on the strap quality.

Tensioning speed: 250 - 340 mm/s / 9.8 - 13.4"/sec.

Joint strength: approx. 75% of the tensile strength of the plastic strap  
(depending on the strap quality).

### Working temperature

The ambient temperature should be between 5° and 45° C (41° and 113°F).

The best performance is achieved between 15° and 20°C (59° and 68°F).

### 3 ACCESSORIES



Use only parts and accessories mentioned in the operating instruction. Using other parts or accessories can cause injuries to you and other persons.

#### 3.1 Battery

Since the tool can be operated with NiCd or NiMH batteries, the battery is not automatically supplied with the tool. The battery has to be ordered separately under the following item numbers.

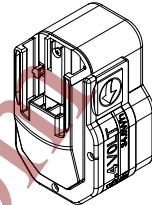

Item-No.	Battery	Voltage	Capacity
N5.4309	NiCd	14,4 VDC	2,4Ah
N5.4316	NiMH	14,4 VDC	2,7Ah

#### 3.2 Battery - chargers

The charge must be ordered separately according to below shown table.

##### Standard charger

Item-No.	Voltage / frequency	Admitted for country
N5.4414	220 - 240V / 50 - 60Hz	A, B, BG, BIH, BOL, BR, BY, CH, CL, CZ, D, DK, DZ, E, EAS, EST, ET, F, FIN, GE, GR, H, HK, HR, I, IL, IND, IR, IRQ, IS, JOR, KSA, KWT, L, LAR, LT, LV, MA, MC, MK, MOC, N, NL, P, PK, PE, PL, PRC, PY, RA, RCH, RI, RL, RO, ROK, ROU, RP, RUS, S, SK, SLO, SYR, THA, TN, TR, UA, UAE, YU, YV, (Z), (ZA), (ZW)
N5.4416	220 - 240V / 50 - 60Hz	BRN, BRU, CY, EAK, EAT, GB, IRL, M, MAL, OM, SGP, Y
N5.4418	220 - 240V / 50 - 60Hz	AUS, NZ
N5.4420	220V / 60Hz	ROK

##### Turbo charger

Item-No.	Voltage / frequency	Admitted for country
N5.4422	220 - 240V / 50 - 60Hz	A, B, BG, BIH, BOL, BR, BY, CH, CL, CZ, D, DK, DZ, E, EAS, EST, ET, F, FIN, GE, GR, H, HK, HR, I, IL, IND, IR, IRQ, IS, JOR, KSA, KWT, L, LAR, LT, LV, MA, MC, MK, MOC, N, NL, P, PK, PE, PL, PRC, PY, RA, RCH, RI, RL, RO, ROK, ROU, RP, RUS, S, SK, SLO, SYR, THA, TN, TR, UA, UAE, YU, YV, (Z), (ZA), (ZW)
N5.4424	120V / 60Hz	BR, C, CDN, CO, CR, DOM, EC, GCA, J, JA, KSA, LB, MEX, NIC, PA, Puerto Rico, RC, RP, USA, YV
N5.4426	110V / 50 - 60Hz	GB
N5.4428	220 - 240V / 50 - 60Hz	BRN, BRU, CY, EAK, EAT, GB, IRL, M, MAL, OM, SGP, Y
N5.4430	220 - 240V / 50 - 60Hz	AUS, NZ

##### Charging times

	Standard charger	Turbo charger
<b>NiCd-Battery 14,4 VDC, 2,4Ah</b>	approx. 80 min.	approx. 20 min.
<b>NiMH-Battery 14,4 VDC, 2,7Ah</b>	approx. 85 min.	approx. 25 min.

### 3.3 Wearing plate

As an option, tool can be equipped with a wearing plate to protect base from excessive wear on abrasive package surfaces (like bricks, concrete blocks etc.).

The complete wearing plate can be ordered together with the fastening screws under item number P32.0111.

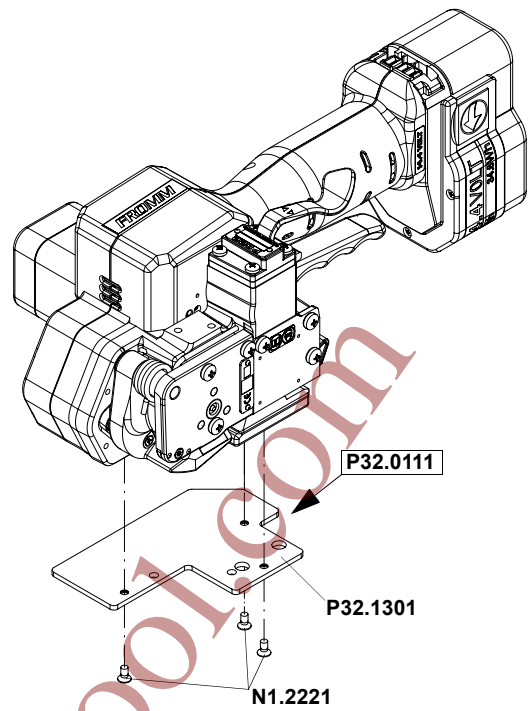

### 3.4 Suspension

When working stationary the P322 can be suspended at a spring loaded balancer by using a suspension bracket.

For working in normal position a stiff suspension bracket with screws and washers can be ordered under item number P32.0112.

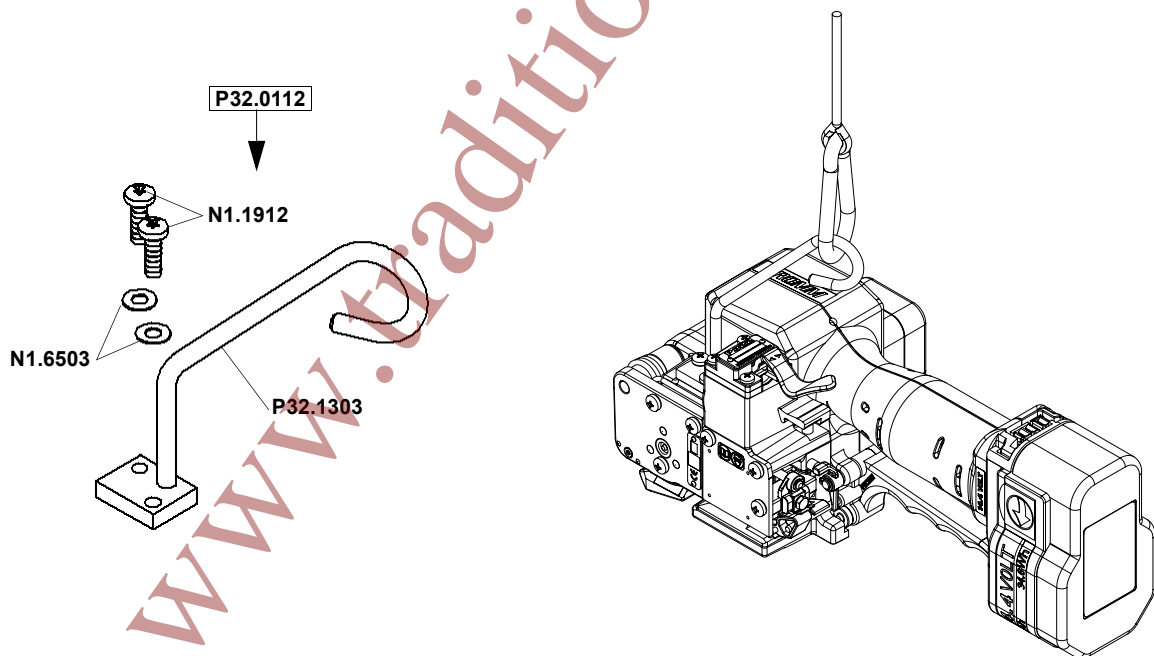

For working in alternating positions a turn able suspension bracket with screws and washers can be ordered under item number P32.0137.

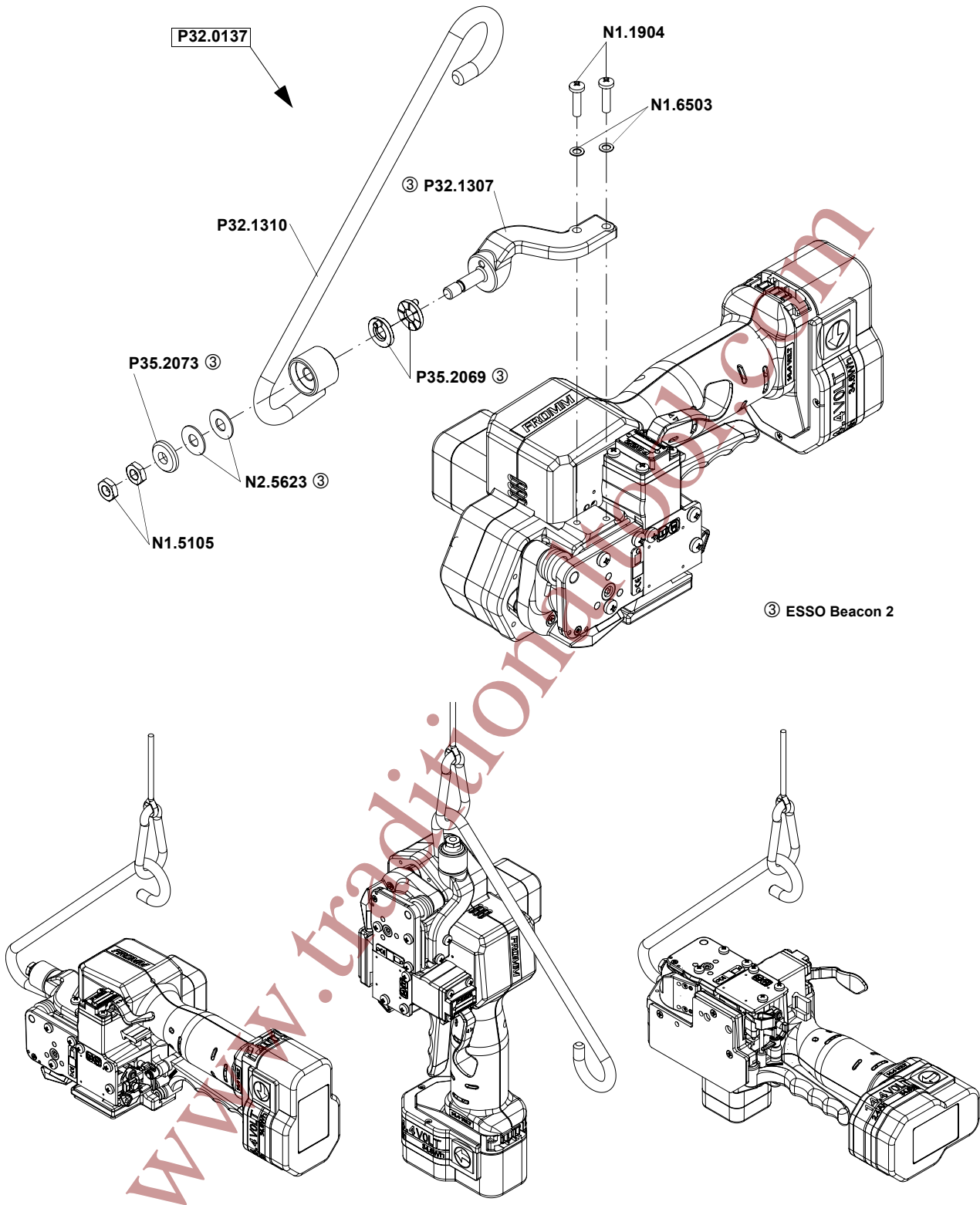

### 3.5 Turning button kit

For a remaining adjustment of tension force and welding time. After exchanging of the turning buttons the adjustment can only be changed with the allen key (2mm) that comes with the kit. The kit can be ordered under the item number P32.1129.



## 4 OPERATING ELEMENTS

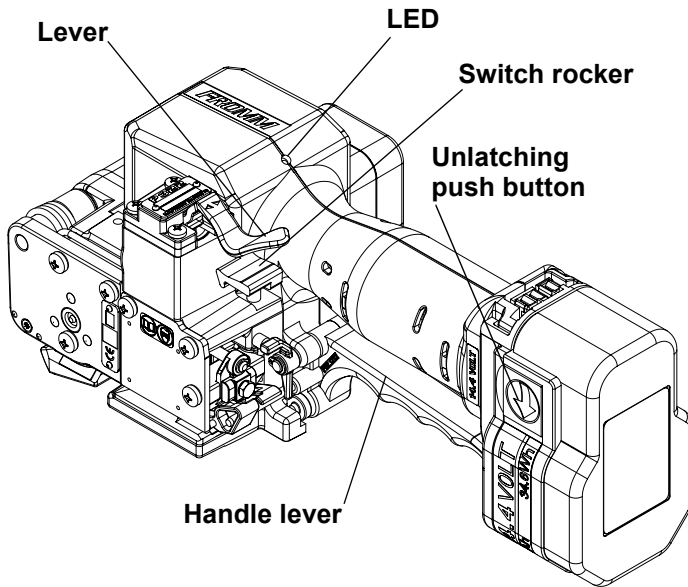

LED - Indication	
Green	During tensioning the LED lights green.
Green	During welding the LED lights green.
Yellow	Cooling time is running, the tool must not be removed from the strap.
Green	Cooling time is finished, the tool can be removed from the strap.
Red	Charge the battery.
Red blinking	The control board is overheated, the tool has to cool down, the switches are locked.

## 5 OPERATION

### 5.1 Installation

**Do not expose the tool to rain!**

For safety reasons the battery is delivered uncharged. Charge the battery before working. See separate operating instruction of the battery charger.

### Inserting the battery

Insert the battery from bottom to top into the tool **both unlatching push buttons latch**. Depending on the application, the battery can also be inserted from top to bottom in order to achieve a better handling.

When inserting the battery the status of the charge is displayed shortly.

### Displaying of the status of the battery charge by LED

Green blinking	full
Green yellow blinking	3/4 full
Yellow blinking	1/2 full
Yellow - red blinking	1/4 full
Red blinking	empty

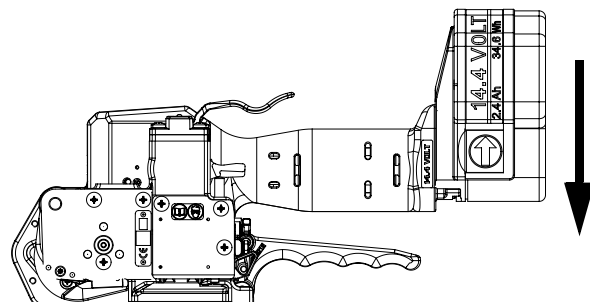
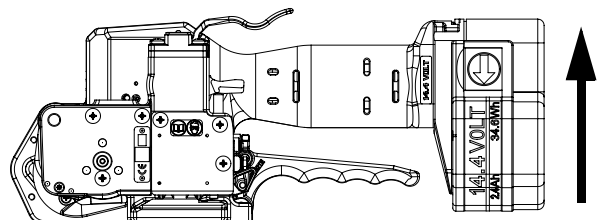



## Removing the empty battery

If the red LED starts lighting while a tensioning or welding procedure, the capacity of the battery is exhausted. All electric functions of the tool are blocked. The seal efficiency is insufficient.

**Warning! Straps with insufficient seal strength must be removed from the package!**

The battery must be recharged.

Push the unlatching push buttons at both sides of the battery.  
Push the battery out of the tool in the opposite direction of insertion.  
When removing the battery the LED lights shortly red.

## 5.2 Adjustments

### 5.2.1 Preselecting of strap tension and tensioning speed



**Do not adjust the tensioning force too high.**

**If the tensioning force is higher than the tensioning strength of the strap, the strap will tear while the tensioning.**

Tensioning force and tensioning speed can be preselected with the right adjusting knob.

Turning clockwise increases;

turning counterclockwise decreases the tensioning force and the tensioning speed resp.

The tensioning force on the minimum setting is 400 N (90 lbs) and it is increased on the maximum setting to 2000 N (450 lbs).

The tensioning speed on the minimum setting is 250 mm/s (9.8 inch/sec), it is increased on the middle setting to 340 mm/s (13.4 inch/sec) and remains on this value till the maximum setting.

### 5.2.2 Adjusting the welding time

Depending on the size and quality of the strap, different welding times are required.

The welding time can be adjusted at the left adjusting knob.

Turning clockwise increases,

turning counterclockwise decreases the welding time.

## 5.3 Feeding the strap around the package

The strapping is fed around the package as illustrated.



**Warning! The plastic strap which will be welded must be free from oil, grease and other dirt.**

**Dirty plastic straps can't be welded correct!**

Adjusting knob tensioning force / tensioning speed

Adjusting knob welding time

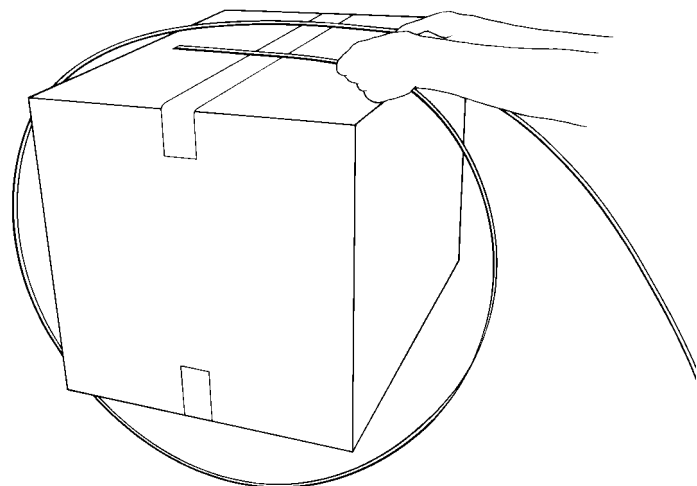
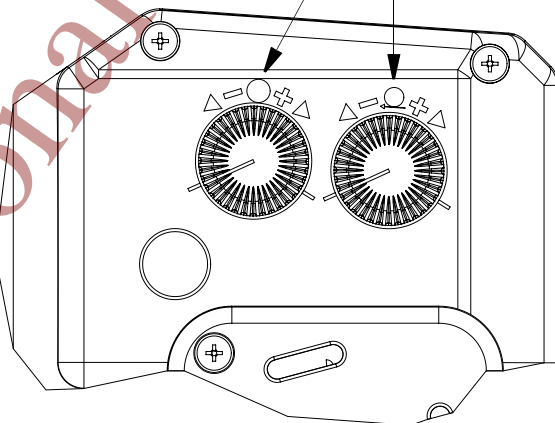

## 5.4 Inserting the strap

Pull up the handle lever firmly with your right hand.  
Insert the two straps well aligned on each other into the strap guide using your left hand.  
Release the handle lever.

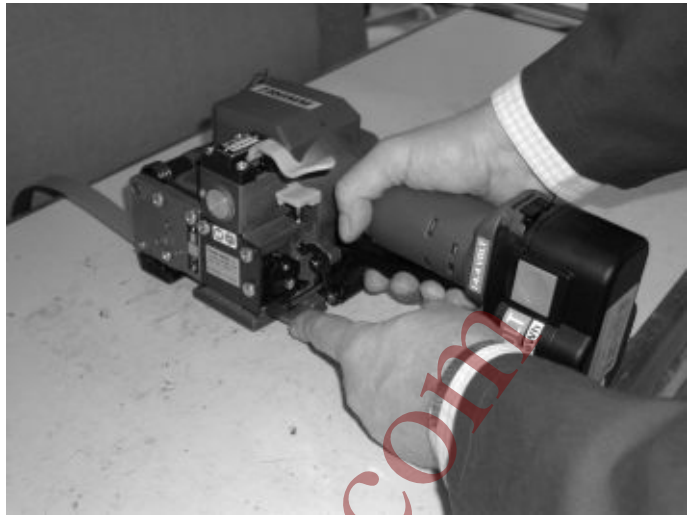

## 5.5 Tensioning the strap

Press down the switch rocker and then release it again after the desired strap tension has been reached.

The tensioning operation can be interrupted and restarted at any time.

During tensioning the LED lights green.

**Do not press the switch rocker after reaching the preselected tensioning.**

**Danger of strap breakage.**

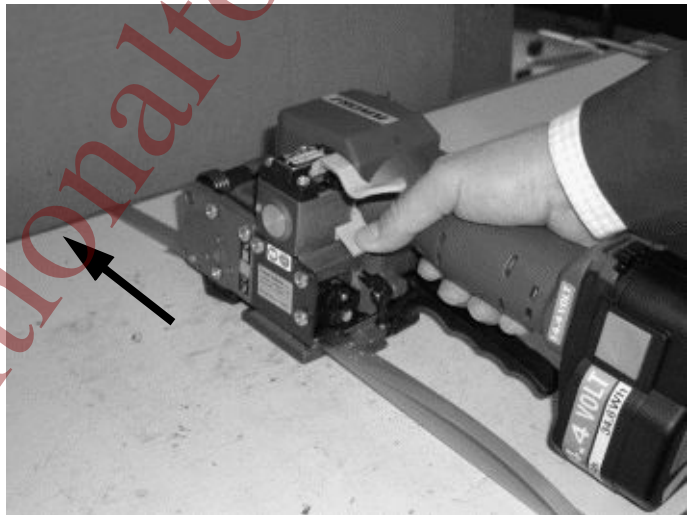

The tool must carry out a balance movement while tensioning.

Therefore:

- Don't hinder the tools movement in the signed direction.

Disregard:

- The feed wheel slips on the strap without tensioning it.

## 5.6 Sealing of the joint

Press sealing lever down and let it go immediately. The plastic strap is welded and cut off from the rest of the strap.

During the welding the LED lights green.

After elapsing of the adjusted welding time (see 5.2.2) the cooling time begins (LED lights yellow). During that time the tool must not be removed from the strap.

If the LED lights green again, the sealing cycle is finished.

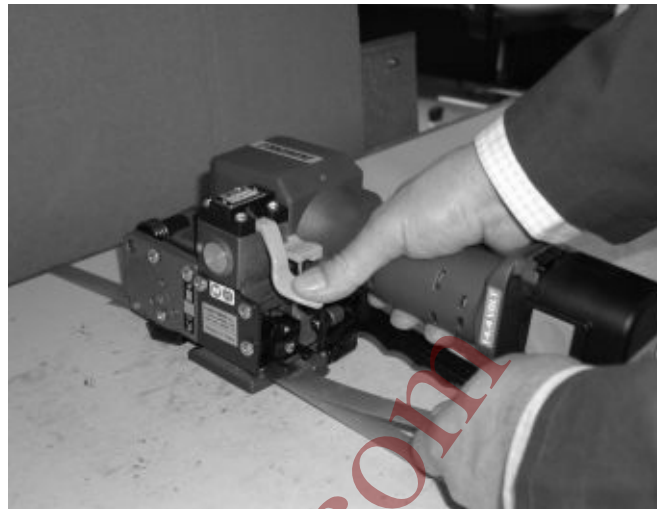

The tool must not be removed from the strap as long as the cooling time is not finished. Disregard of this regulation is causing insufficient seal efficiencies, which can cause severe injuries.

## 5.7 Removing the tool

Pull up the handle lever, pull the tool right / backwards and off the strapping.



## 5.8 Seal - Control

A regular control of the seal is necessary. The seal can be examined visually. Make a seal, peel it apart and examine it as follows:



### Correct seal

The seal must be completely welded over the whole width of the strap on a length of ca. 19 mm. Minor quantities of fused plastic may overflow on sides.



### Welding time too short

The plastic strap is not welded over the whole width of the strap. The seal efficiency is insufficient. Warning! Straps with insufficient seal strength must be removed from the package! Adjust the welding time (see 5.2.2).



### Welding time too long

If the welding time is too long the straps are overheated. The fused plastic overflows on both sides of the straps. The seal efficiency is affected. Warning! Straps with insufficient seal strength must be removed from the package! Adjust the welding time (see 5.2.2).

## 6 CHART OF TYPES

Item No.	Model	Strap width	Strap thickness
43.2101	P322/10/0.40-0.64	10 mm / 3/8"	0.4 - 0.64 mm / .016 - .025"
43.2102	P322/10/0.65-1.05	10 mm / 3/8"	0.65 - 1.05 mm / .026 - .041"
43.2111	P322/11.1/0.40-0.64	11.1 mm / 7/16"	0.4 - 0.64 mm / .016 - .025"
43.2112	P322/11.1/0.65-1.05	11.1 mm / 7/16"	0.65 - 1.05 mm / .026 - .041"
43.2121	P322/12/0.40-0.64	12 mm	0.4 - 0.64 mm / .016 - .025"
43.2122	P322/12/0.65-1.05	12 mm	0.65 - 1.05 mm / .026 - .041"
43.2123	P322/12.7/0.40-0.64	12.7 mm / 1/2"	0.4 - 0.64 mm / .016 - .025"
43.2124	P322/12.7/0.65-1.05	12.7 mm / 1/2"	0.65 - 1.05 mm / .026 - .041"
43.2131	P322/13/0.40-0.64	13 mm	0.4 - 0.64 mm / .016 - .025"
43.2132	P322/13/0.65-1.05	13 mm	0.65 - 1.05 mm / .026 - .041"
43.2151	P322/15/0.40-0.64	15 mm	0.4 - 0.64 mm / .016 - .025"
43.2152	P322/15/0.65-1.05	15 mm	0.65 - 1.05 mm / .026 - .041"
43.2153	P322/15.5/0.40-0.64	15.5 mm	0.4 - 0.64 mm / .016 - .025"
43.2154	P322/15.5/0.65-1.05	15.5 mm	0.65 - 1.05 mm / .026 - .041"
43.2161	P322/16/0.40-0.64	16 mm / 5/8"	0.4 - 0.64 mm / .016 - .025"
43.2162	P322/16/0.65-1.05	16 mm / 5/8"	0.65 - 1.05 mm / .026 - .041"

## 7 ELECTRIC SCHEMATIC

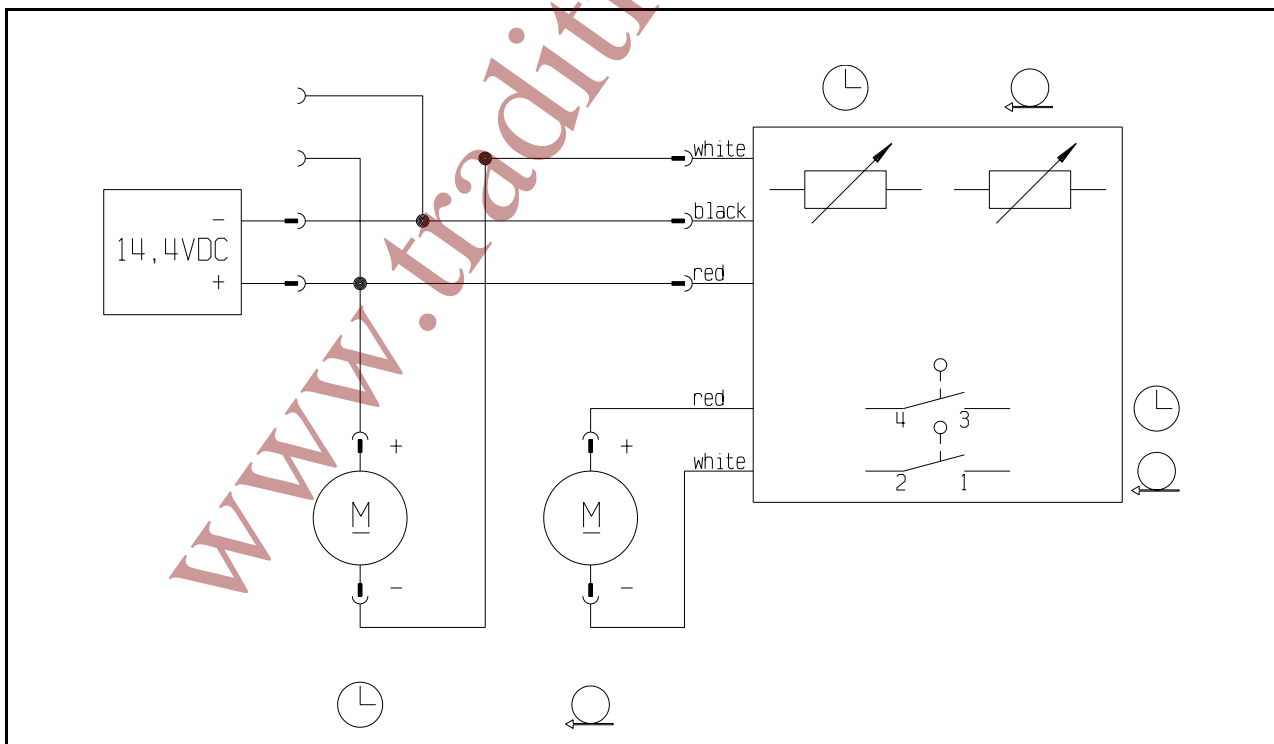

## 8 EXCHANGE OF WEARING PARTS



Remove always the battery from the tool before starting maintenance works.

### 8.1 Exchange of tensioning wheel and grippers

#### Disassembling

- Unscrew end cover P32.1238 and remove it;
- Remove the torsion spring N2.5823;
- Remove the tensioning body P32.1254;
- Remove the tensioning wheel together with the bearing N3.1172 from the tool;
- Unscrew the holders P32.1228 and P32.1229 and remove them from the tensioning body;
- Remove the grippers from the tensioning body.

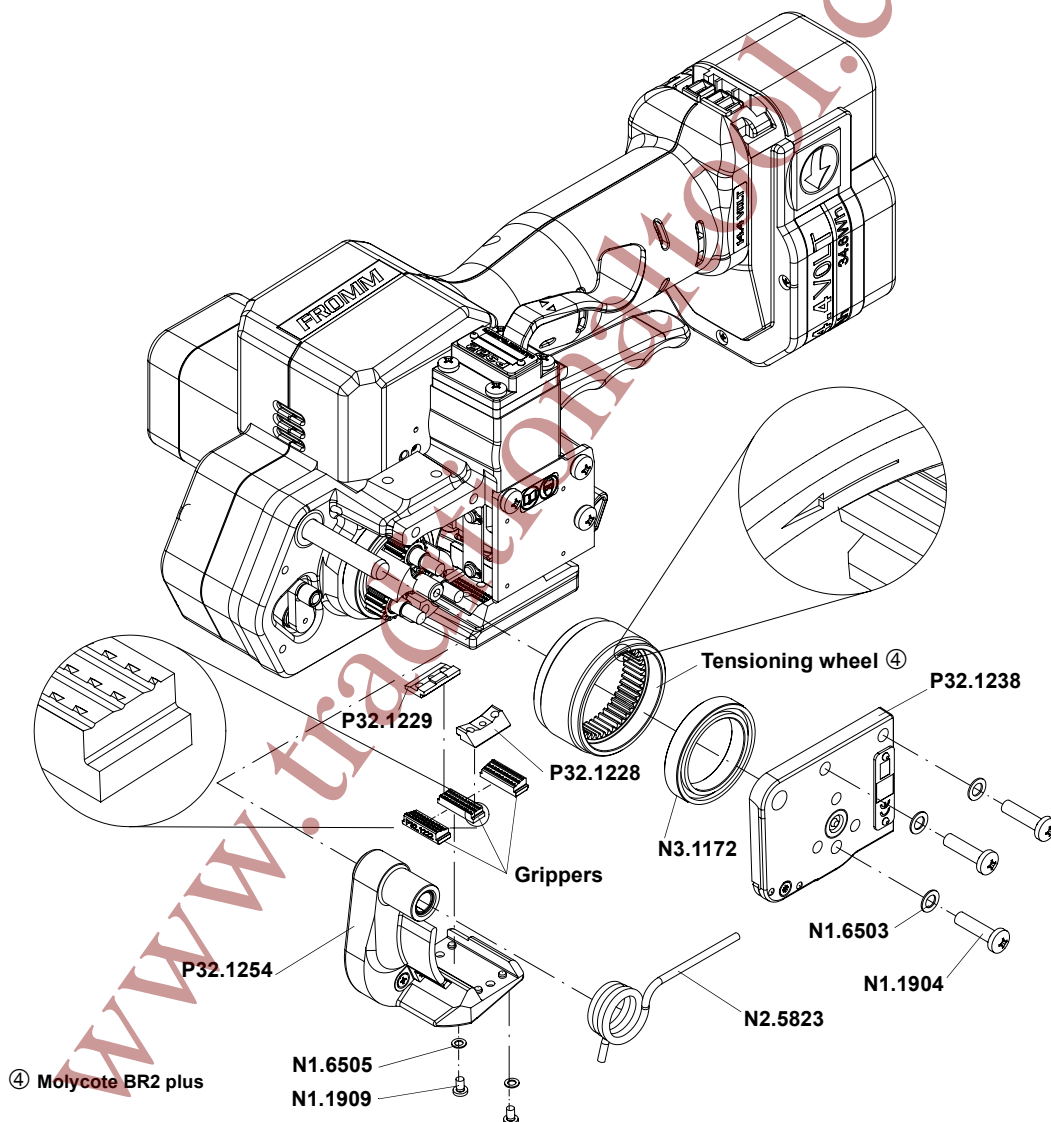

#### Assembling

Assembling in opposite order. Observe the following:

- Lubricate the internal tooting of the tensioning wheel with Molykote BR 2 plus.



**Observe the position of the tensioning wheel. The direction of rotation of the tensioning wheel is marked at the front of the tensioning wheel (see drawing).**  
**Observe the position of the grippers (see drawing).**

## 8.2 Exchange of cutter, welding stop gripper and welding gripper

### Disassembling

- Unscrew cover P32.1211 and remove it;
- Unscrew end cover P32.1238 and remove it;
- Remove security ring N2.1118 and pull handle shaft P32.1415 out of the tool.  
This is loosening the lever P32.1414;
- Tilt down the handle lever P32.1212 and remove it from the tool;
- Don't loosen screw N1.1553 at the coupler P32.1250.
- Disassemble the security ring N2.1121 from the coupler P32.1250, remove the coupler;
- Pull out the centering sleeve P32.1208 from the guide case to left, disassemble the guide case;
- Pull out the pressure spring N2.5237 with a screw driver from the cutter P32.1204;
- Remove the cutter from the driving pin P32.1032;
- Disassemble the screws N1.1305, lift slightly the welding stop gripper P32.1203 and the steel insert and remove them from the tool;
- Push the steel insert without welding stop gripper under the welding gripper P32.1053 until it touches the parallel pin N2.2110;
- Press down lever P32.1406;
- Disassemble the safety ring N2.1121 from the bolt P32.1028, remove the bolt from the welding gripper;
- Press in coupler P32.1410 in order to release the lever P32.1406 again;
- Pull out the steel insert with care to right under the welding gripper;
- Disassemble the security rings N2.1121 from the driving pin P32.1032, remove the driver P32.1035 from the driving pin;
- Lift the rocker P32.1024 behind the welding gripper with a screw driver, remove the welding gripper together with the ball cage P32.1027 and the balls N3.1702 from the tool;
- Lower the rocker, remove the thrust piece P32.1029 from the tool.

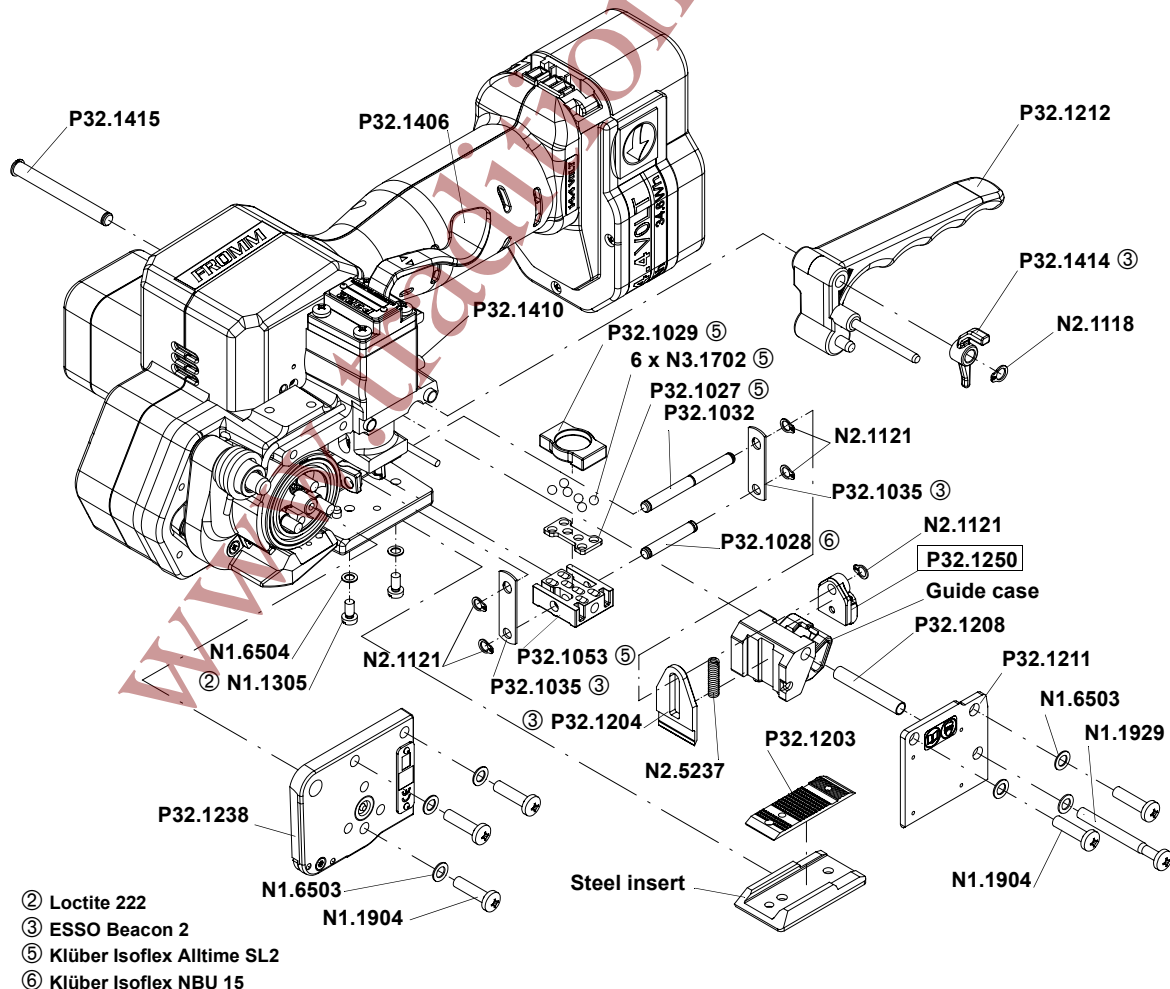



## Assembling

Assembling in opposite order. Observe the following:



**Pay attention to the fitting position of the cutter (see drawing).  
Safe the screws N1.1305 with Loctite 222.**

## Lubrication

- Lubricate the rocker and the bolt P32.1028 in the area of the welding jaw with Klüber Isoflex NBU 15.
- Lubricate the balls, ball cage and the running surface of the balls on the welding gripper with Klüber Isoflex Alltime SL2.
- Lubricate the cutter and the driver with Esso Beacon 2.

## 8.3 Adjustment of the coupler P32.1250

The coupler is adjusted in our works.

In case of replacing the seesaw lever, the coupler or the lever body, the coupler has to be readjusted.

Procedure as follows:

The battery is removed from the tool.  
The coupler is fitted into the tool.

- Loosen screw N1.1553.
- Displace thrust piece P32.1252, so that it touches the two seesaw levers without moving them.
- Retighten screw N1.1553.

### Control:

The thrust piece must touch the seesaw levers (X1).  
Both guide pins must sit on the welding stop gripper (X2).

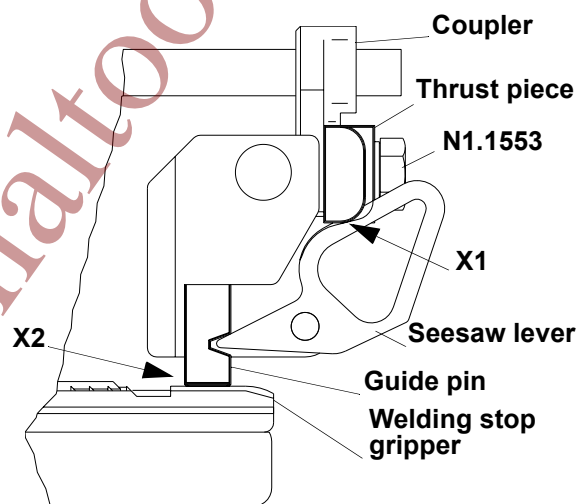



---

## 9 WARRANTY CONDITIONS AND LIABILITY

FROMM Holding AG warrants all its strapping tools and machine heads during a period of 90 days from the date of sale. The warranty includes all deficiencies clearly resulting from poor manufacturing or faulty materials. Damage claims as a result of production shutdowns and claims for damage to persons and to property resulting from warranty deficiencies cannot be asserted by the customer.

The warranty excludes:

wearing parts,  
deficiencies resulting from improper installing, incorrect handling and maintaining the tool,  
deficiencies resulting from using the tool without or with defective security- and safety devices,  
disregard of directions in the operation manual,  
arbitrary modifications of the tool,  
deficient control of wearing parts,  
deficient repair works of the tool.  
Use of consumable products not recommended by FROMM Holding AG

We reserve the right to modify the product at any time in order to improve its quality.

## 10 APPROPRIATE USE

The tool model P322 has been designed to strap packages with plastic strapping exclusively. The warranty / liability excludes:

- non appropriate use of the tool,
- disregard of directions in the operation manual,
- disregard of control- and maintenance instructions.

## 11 SERVICE

Servicing and repair work must only be carried out by authorized service centres. If the tool breaks down or does no longer operate do not disassemble it. Send it fully assembled to the local service centre (see name and address on the rear page of this manual). Use original packing.

The battery powered plastic strapping tool P322 is a high performance tool. We strongly recommend you to have it serviced by an authorized service shop after 12 months at the latest if used one shift per day. If used two or more shifts per day the tool has to be serviced after a shorter period of time.

## 12 CLEANING

Clean strap gripping parts from strap abrasion regularly using compressed air (do not use any mechanical tool for cleaning).

When cleaning the surface of the tool do not use water or aggressive solvents!

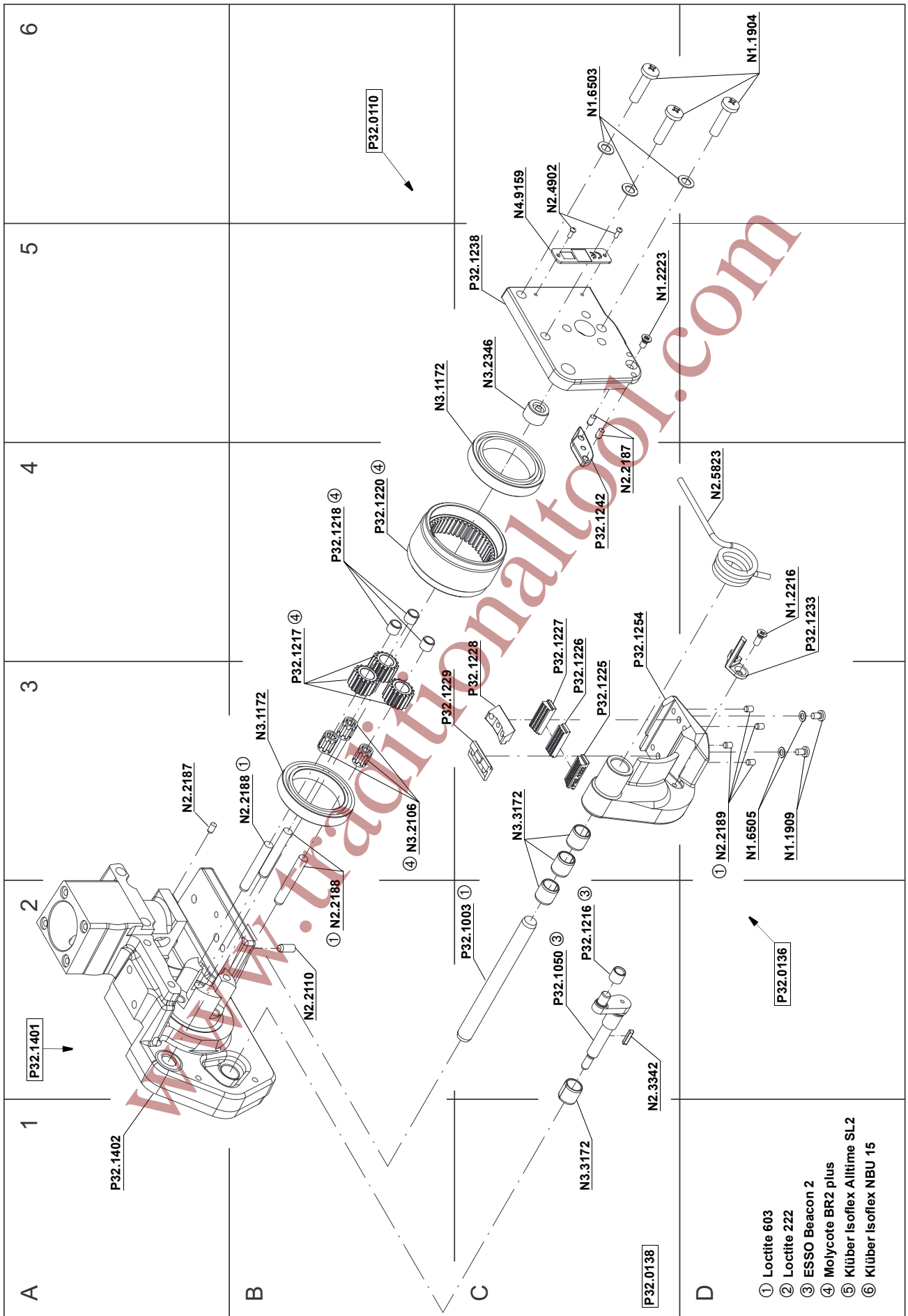

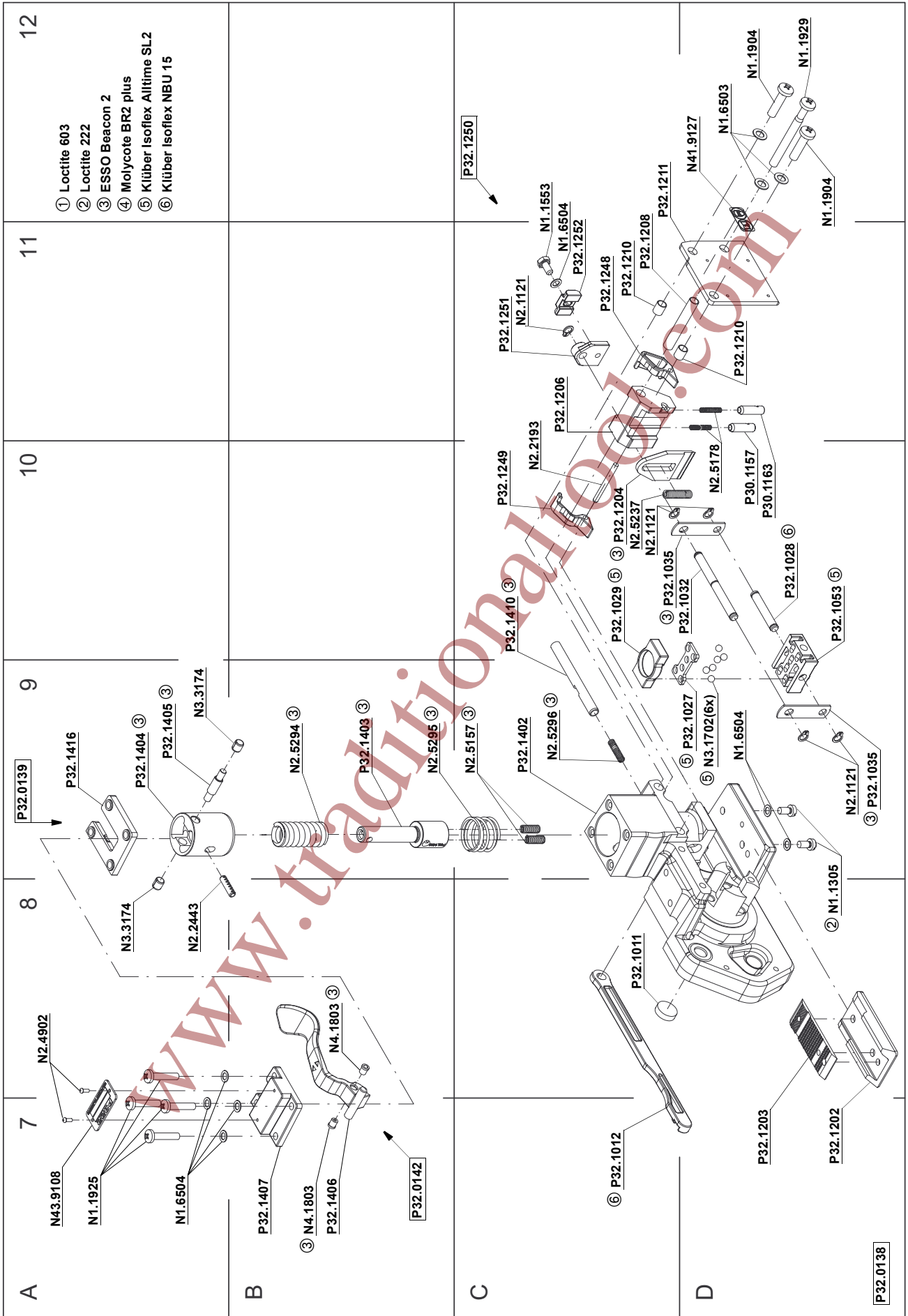

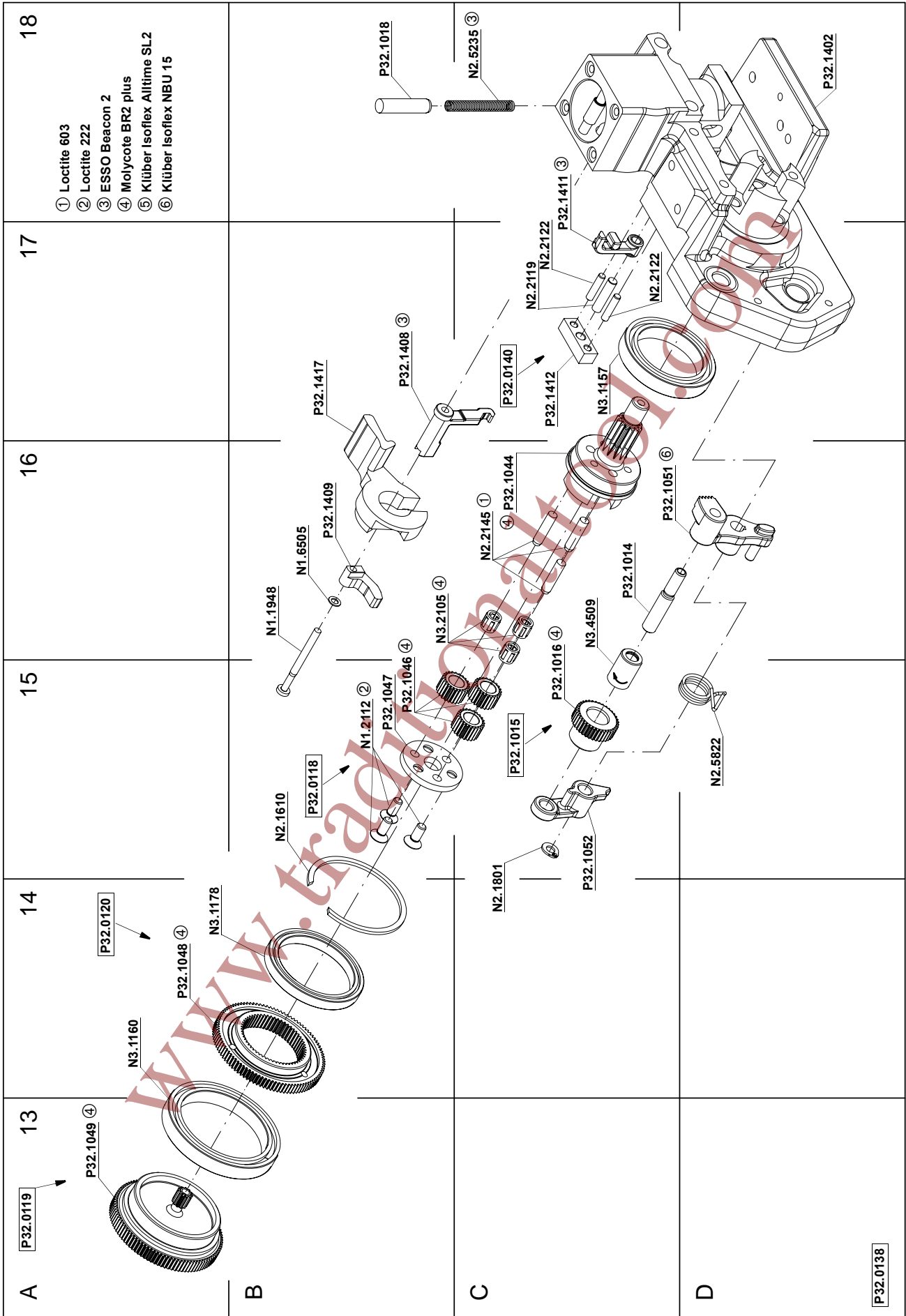

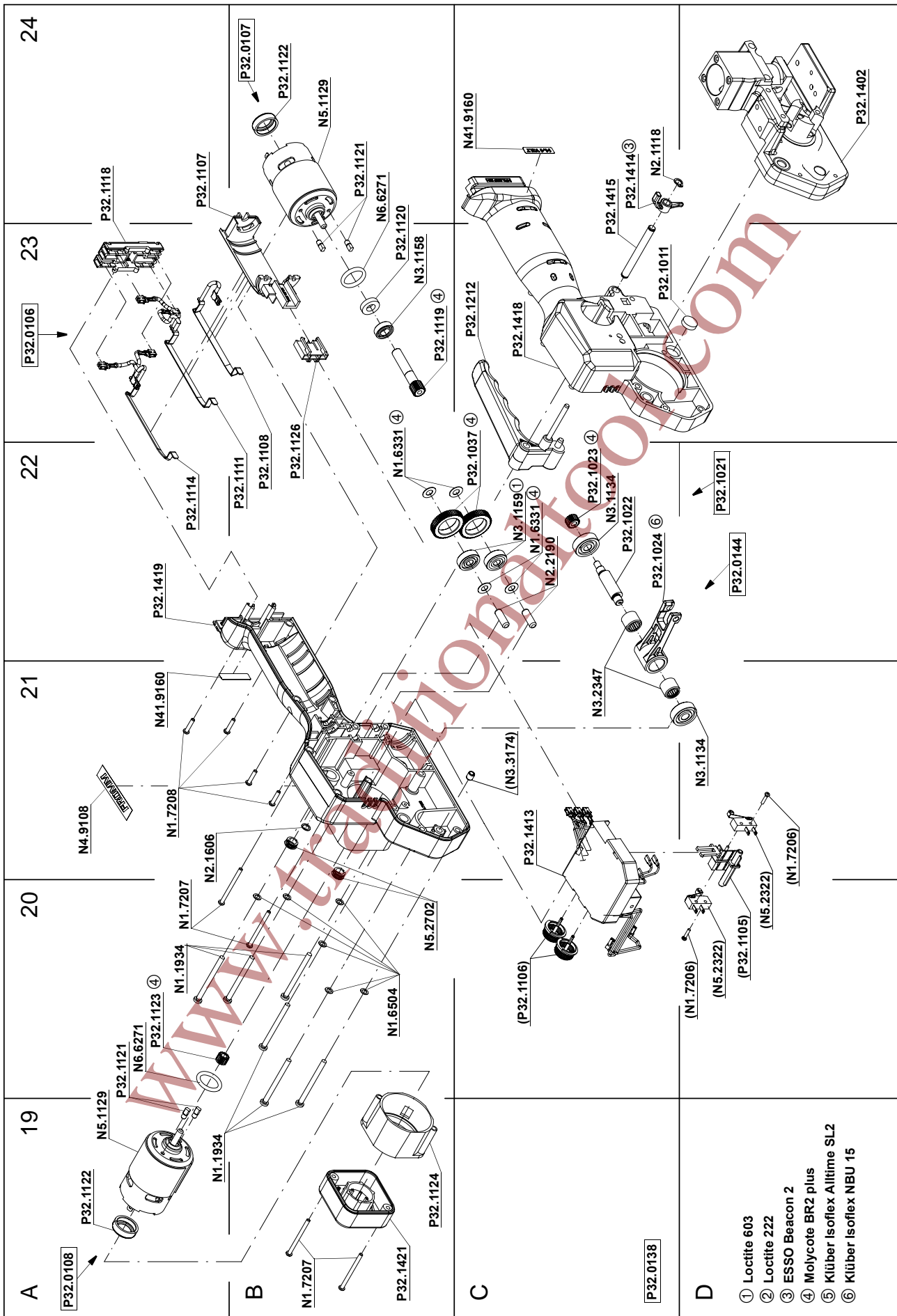

### 13 SPARE PARTS LIST 43.2124.01

43.2124.01	P322/12.7/0.65-1.05		P322.0001.01		09.09.05	
Item-No.		in group	Pcs.	Description	Dimension	Field
N1.1305			2	SCREW	M4 X 7.8	D8
N1.1553		P32.1250	1	HEXAGON SCREW	M4 X 8	C12
N1.1904			5	SCREW	M5 X 20	C6+
N1.1909			2	FLAT HEAD SCREW	M3 X 5	D3
N1.1925		P32.0138	4	SCREW	M4 X 20	A7
N1.1929			1	SCREW	M5 X 50	D12
N1.1934		P32.0138	6	FLAT HEAD SCREW	M4 X 50	A19+
N1.1948		P32.0138	1	SCREW	M3 X 35	B16
N1.2112		P32.0118	3	COUNTERSUNK SCREW	M4 X 10	B15
N1.2216			1	COUNTERSUNK SCREW	M3 X 8	D4
N1.2223			1	COUNTERSUNK SCREW	M3 X 6	C5
N1.6331		P32.0138	4	SPACER WASHER	6 X 12 X 0.5	C22+
N1.6503			6	SAFETY WASHER	M5	C6+
N1.6504			2	SAFETY WASHER	M4	D9
N1.6504		P32.0138	10	SAFETY WASHER	M4	A7+
N1.6504		P32.1250	1	SAFETY WASHER	M4	C11
N1.6505			2	SAFETY WASHER	M3	D3
N1.6505		P32.0138	1	SAFETY WASHER	M3	B16
N1.7206		P32.1413	2	PT-SCREW	2.2 X 10	D20+
N1.7207		P32.0138	4	PT-SCREW	3 X 40	A20+
N1.7208		P32.0138	4	PT-SCREW	3 X 14	A21
N2.1118			1	SECURITY RING	6	C24
N2.1121			1	SECURITY RING	5	C11
N2.1121		P32.0138	4	SECURITY RING	5	D9+
N2.1606			1	SPRING RING	SW6	A21
N2.1610		P32.0138	1	SPRING RING	SB44	B15
N2.1801		P32.0138	1	TENSIONING RING	4	C14
N2.2110		P32.1401	1	PARALLEL PIN	4 m6 X 10	B2
N2.2119		P32.0140	1	PARALLEL PIN	4 m6 X 18	C17
N2.2122		P32.0140	2	PARALLEL PIN	3 h6 X 14	C17
N2.2145		P32.0118	3	PARALLEL PIN	4 h6 X 18	C16
N2.2187		P32.0110	2	PARALLEL PIN	3 m6 X 6	C4
N2.2187		P32.1401	1	PARALLEL PIN	3 m6 X 6	A3
N2.2188		P32.1401	3	PARALLEL PIN	5 h6 X 34	B2+
N2.2189		P32.0136	4	PARALLEL PIN	3 m6 X 5	D3
N2.2190		P32.0138	2	PARALLEL PIN	6 h6 X 18	C22
N2.2193			1	PARALLEL PIN	3 m6 X 32	C10
N2.2443		P32.0139	1	DOWEL PIN	4 X 15	A8
N2.3342		P32.0138	1	FEATHER KEY	2 X 2 X 10	C2
N2.4902			4	HAMMER HEAD BOLT	1.85 X 4.76	C6+
N2.5157		P32.0138	2	PRESSURE SPRING	0.6 X 4.8 X 20/15.5	C9
N2.5178			2	PRESSURE SPRING	0.32 X 2.82 X 20.5/ 20.5	D10
N2.5235		P32.0138	1	PRESSURE SPRING	0.5 X 4.50 X 42.4/28.5	C18
N2.5237			1	PRESSURE SPRING	0.8 X 4.8 X 25/18.5	C10
N2.5294		P32.0139	1	PRESSURE SPRING	2.5 X 15 X 46.5/9.5	B9
N2.5295		P32.0138	1	PRESSURE SPRING	1.5 X 21 X 27/5.5	B9
N2.5296		P32.0138	1	PRESSURE SPRING	0.5 X 4 X 24/16.5	C9
N2.5822		P32.0138	1	TORSION SPRING	1.25 X 12/3.75	D15
N2.5823			1	TORSION SPRING	2.8 X 17/4	D4
N3.1134		P32.0138	1	BALL BEARING	7 X 22 X 7	D21

[ ] = Group

\* = Wearing parts



43.2124.01	P322/12.7/0.65-1.05		P322.0001.01			09.09.05
Item-No.		in group	Pcs.	Description	Dimension	Field
N3.1134		P32.1021	1	BALL BEARING	7 X 22 X 7	C22
N3.1157		P32.0118	1	BALL BEARING	30 X 42 X 7	C17
N3.1158		P32.0107	1	BALL BEARING	8 X 16 X 5	B23
N3.1159		P32.0138	2	BALL BEARING	6 X 19 X 6	C22
N3.1160		P32.0119	1	BALL BEARING	40 X 52 X 7	A14
N3.1172			2	BALL BEARING	30 X 42 X 7	B3+
N3.1178		P32.0120	1	BALL BEARING	35 X 44 X 5	A14
N3.1702		P32.0138	6	BALL	4 MM	D9
N3.2105		P32.0118	3	NEEDLE CAGE	K 4 X 7 X 7 TN	B16
N3.2106			3	NEEDLE CAGE	K 5 X 8 X 10 TN	B3
N3.2346		P32.0110	1	NEEDLE CASE	8 X 12 X 8	C5
N3.2347		P32.0144	2	NEEDLE BUSH	10 X 14 X 12	C21
N3.3172		P32.0136	3	SLIDE-BEARING	8 X 10 X 10	C3
N3.3172		P32.1401	1	SLIDE-BEARING	8 X 10 X 10	C1
N3.3174		P32.0139	2	SLIDE-BEARING	4 X 5.5 X 6	A8+
N3.3174		P32.1419	1	SLIDE-BEARING	4 X 5.5 X 6	C21
N3.4509		P32.1015	1	NEEDLE FREE WHEELING	6 X 10 X 15	C16
N41.9127			1	ADHESIVE LABEL	20 X 10 X 0.1	D12
N41.9160		P32.0138	2	ADHESIVE LABEL	14.4 VOLT	A21+
N43.9108			1	TYPE PLATE	<<P322>>	A7
N4.1803		P32.0142	2	THRUST PIECE		B7+
N4.9108			1	ADHESIVE LABEL	54 X 12 X 0.1	A21
N4.9159			1	LABEL	<<CE>>	C6
N5.1129		P32.0107	1	ELECTRIC MOTOR		B24
N5.1129		P32.0108	1	ELECTRIC MOTOR		A19
N5.2322		P32.1413	2	MICRO SWITCH		D20
N5.2702			1	COVER		B20
N5.2702		P32.0138	1	COVER		B20
N6.6271		P32.0107	1	O-RING	17 X 3.0	B24
N6.6271		P32.0108	1	O-RING	17 X 3.0	A20
P30.1157			1	GUIDE PIN		D10
P30.1163			1	GUIDE PIN		D10
[P32.0106]		P32.0138	1	ENERGY TRANSMISSION		A23
[P32.0107]		P32.0138	1	WELDING MOTOR		B24
[P32.0108]		P32.0138	1	TENSIONING MOTOR		A19
[P32.0110]			1	END COVER		B6
[P32.0118]		P32.0138	1	IDLER STEP		B15
[P32.0119]		P32.0138	1	SPUR WHEEL		A13
[P32.0120]		P32.0138	1	WHEEL		A14
[P32.0136]			1	TENSIONING BODY		D2
[P32.0138]			1	BASE MODEL		C1+
[P32.0139]		P32.0138	1	SPRING PACKAGE		A9
[P32.0140]		P32.0138	1	INSERTATION PART		C17
[P32.0142]		P32.0138	1	LEVER		B7
[P32.0144]		P32.0138	1	ROCKER		D22
P32.1003		P32.1401	1	SWIVEL SHAFT		C2
P32.1011		P32.0138	2	FELT		C8+
P32.1012		P32.0138	1	COUPLER		C7
P32.1014		P32.0138	1	SHAFT		C16
[P32.1015]		P32.0138	1	RATCHET WHEEL		C15
P32.1016		P32.1015	1	SPUR WHEEL		C15
P32.1018		P32.0138	1	CARTRIDGE		B18
[P32.1021]		P32.0138	1	WELDING EXCENTRIC		D22

[ ] = Group

\* = Wearing parts



43.2124.01	P322/12.7/0.65-1.05		P322.0001.01		09.09.05	
Item-No.		in group	Pcs.	Description	Dimension	Field
P32.1022		P32.1021	1	WELDING EXCENTRIC		C22
P32.1023		P32.1021	1	PINION		C22
P32.1024		P32.0144	1	ROCKER		C22
P32.1027		P32.0138	1	BALL CAGE		D9
P32.1028		P32.0138	1	BOLT		D10
P32.1029		P32.0138	1	THRUST PIECE		C10
P32.1032		P32.0138	1	DRIVING PIN		D10
P32.1035		P32.0138	2	DRIVER		D9+
P32.1037		P32.0138	2	SPUR WHEEL		C22
P32.1044		P32.0118	1	PLANET SHAFT		C16
P32.1046		P32.0118	3	IDLER GEAR		B15
P32.1047		P32.0118	1	COVER		B15
P32.1048		P32.0120	1	WHEEL		A14
P32.1049		P32.0119	1	SPUR WHEEL		A13
P32.1050		P32.0138	1	FRONT TOGGLE LINK		C2
P32.1051		P32.0138	1	LEVER		C16
P32.1052		P32.0138	1	STANCHION		C15
P32.1053	*	P32.0138	1	WELDING GRIPPER		D10
P32.1105		P32.1413	1	RETAINER		D20
P32.1106		P32.1413	2	TURNING BUTTON		C20
P32.1107		P32.0106	1	MOTOR SUPPORT		A24
[P32.1108]		P32.0106	1	BUSBAR		B22
[P32.1111]		P32.0106	1	BUSBAR		B22
[P32.1114]		P32.0106	1	BUSBAR		A22
P32.1118		P32.0106	1	CONNECTING PLATE		A24
P32.1119		P32.0107	1	PINION		B23
P32.1120		P32.0107	1	FELT WASHER		B23
P32.1121		P32.0107	2	TORSIONAL STOP		B24
P32.1121		P32.0108	2	TORSIONAL STOP		A20
P32.1122		P32.0107	1	RUBBER BUSHING		B24
P32.1122		P32.0108	1	RUBBER BUSHING		A19
P32.1123		P32.0108	1	PINION		A20
P32.1124		P32.0138	1	INSERT		B19
P32.1126		P32.0106	1	PLUG SOCKET		B22
P32.1202			1	STEEL INSERT		D7
P32.1203	*		1	WELDING STOP GRIPPER		D7
P32.1204	*		1	CUTTER		C10
P32.1206			1	GUIDE CASE		C11
P32.1208			1	CENTERING SLEEVE		C11
P32.1210			2	CENTERING SLEEVE		C11+
P32.1211			1	COVER		C12
[P32.1212]			1	HANDLE LEVER		C23
P32.1216			1	PRESSURE ROLLER		C2
P32.1217			3	IDLER GEAR		B4
P32.1218			3	DOWEL		B4
P32.1220	*		1	TENSIONING WHEEL		B4
P32.1225	*		1	GRIPPER		C3
P32.1226	*		1	GRIPPER		C3
P32.1227	*		1	GRIPPER		C4
P32.1228			1	HOLDER		C3
P32.1229			1	HOLDER		B3
P32.1233			1	STRAP STOP		D4
P32.1238		P32.0110	1	END COVER		C5

[ ] = Group

\* = Wearing parts

43.2124.01	P322/12.7/0.65-1.05		P322.0001.01		09.09.05	
Item-No.		in group	Pcs.	Description	Dimension	Field
P32.1242			1	STRAP GUIDE		C4
P32.1248			1	SEESAW LEVER		C11
P32.1249			1	SEESAW LEVER		C10
[P32.1250]			1	COUPLER		C12
P32.1251		P32.1250	1	COUPLER		C11
P32.1252		P32.1250	1	THRUST PIECE		C11
P32.1254		P32.0136	1	TENSIONING BODY		C4
[P32.1401]		P32.0138	1	BODY		A2
P32.1402		P32.1401	1	BODY		A1+
P32.1403		P32.0139	1	SPRING BOLT		B9
P32.1404		P32.0139	1	SPRING SLIDE		A9
P32.1405		P32.0139	1	ROLLER		A9
P32.1406		P32.0142	1	LEVER		B7
P32.1407		P32.0138	1	COVER		B7
P32.1408		P32.0138	1	HOOK		B17
P32.1409		P32.0138	1	ARM		B16
P32.1410		P32.0138	1	COUPLER		C10
P32.1411		P32.0138	1	LEVER		C18
P32.1412		P32.0140	1	INSERTATION PART		C17
[P32.1413]		P32.0138	1	CIRCUIT BOARD	14.4V	C21
P32.1414			1	LEVER		C24
P32.1415			1	HANDLE SHAFT		C24
P32.1416		P32.0138	1	FIXING PLATE		A9
P32.1417		P32.0138	1	SWITCH ROCKER		B17
P32.1418		P32.0138	1	MOTOR HOUSING		C23
[P32.1419]		P32.0138	1	MOTOR HOUSING		A22
P32.1421		P32.0138	1	MOTOR COVER		B19

[ ] = Group

\* = Wearing parts