

OPERATION, PARTS AND SAFETY MANUAL

SIGNODE®

**MODELS ASL & ASM
COMBINATION STRAPPING TOOLS**

**IMPORTANT!
DO NOT DESTROY**

It is the customer's responsibility to
have all operators and servicemen
read and understand this manual.

Contact your local Signode representative
for additional copies of this manual.

READ ALL INSTRUCTIONS BEFORE OPERATING THIS SIGNODE PRODUCT

! SAFETY INSTRUCTIONS !

Read these instructions carefully.

Failure to follow these instructions can result in severe personal injury.

GENERAL SAFETY CONSIDERATIONS

1. Before using tool read its operation instructions.
2. Several combinations of strap, seals and tools can be used with this tool. Use the correct Signode products for your application. If you need help contact your local Signode representative.
3. Wear eye, face and hand protection.

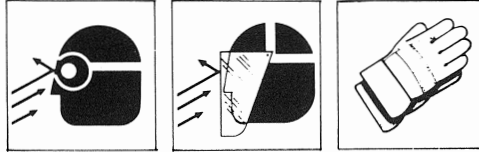

4. Keep work areas uncluttered and well lighted.
5. Take good care of the tool. Inspect and adjust it daily. Replace worn or broken parts. Clean and lubricate it weekly.
6. Seals must be properly crimped or notched. Follow the operating instructions in this manual.
7. While tensioning or sealing, position yourself to one side of the strap.
8. Maintain proper footing and balance when operating tool. Do not use tool when you are in an awkward position.
9. Retract strap end back into dispenser when not in use.

SAFETY PROCEDURES FOR TOOL OPERATION

1. Follow the operating instructions.
2. Place strap properly around the load.
3. Make sure straps are properly inserted into tool.
4. Follow operating instructions for correct strap tensioning procedures.
5. When applying final tension do not apply excess force on the handle as this can cause strap to break.
6. Apply tensions that are proper for the size and type of strap being used, and that is compatible with the loads being strapped, including their corner characteristics. Determine tensioning levels by trial.
7. Crimp or notch seal properly.

SAFETY PROCEDURE FOR CUTTING TENSIONED STRAP

- Wear eye, face and hand protection.
- Hold strap against the load, above cutter. (See Fig. 1).
- Before cutting strap, make sure all personnel are at a safe distance.
- Cut strap between seal and hand holding strap. (See Fig. 1).

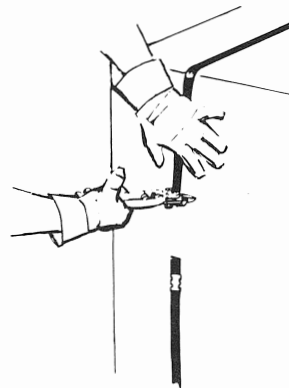
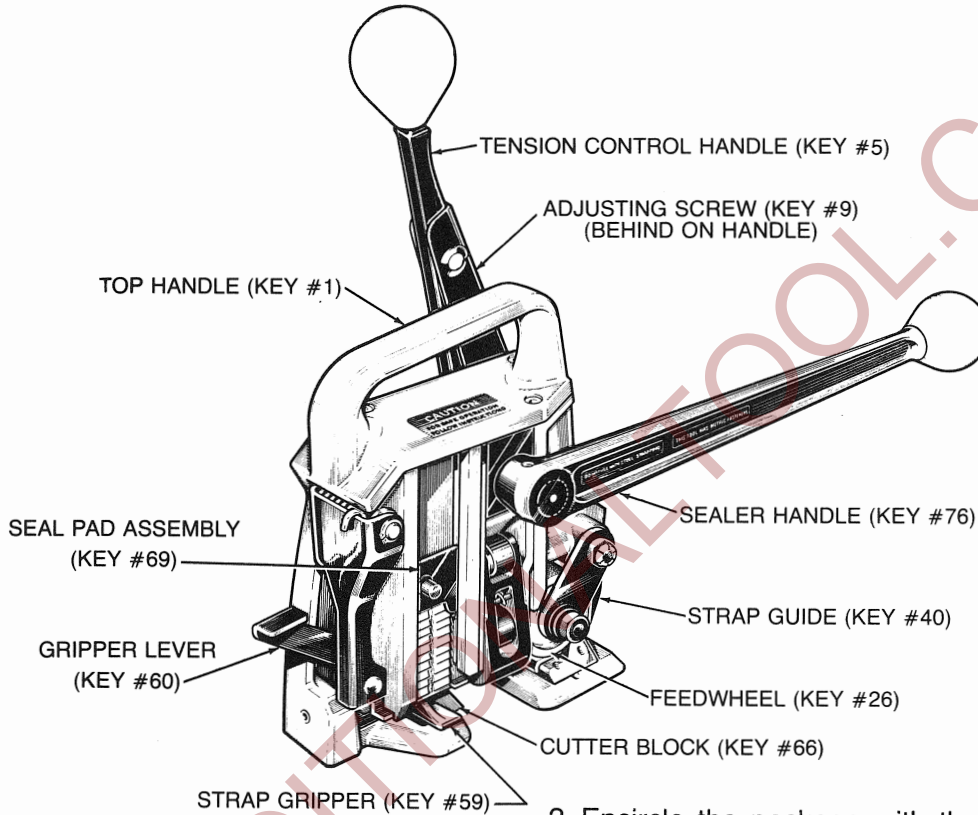

FIGURE 1.

Safety instructions in Spanish are available from your Signode sales representative. / Su vendedor Signode le puede proporcionar los instructivos de seguridad en español.

OPERATING INSTRUCTIONS

TOOL	SEAL	STRAPPING		
		MODEL NO.	DYMAX®	CONTRAX®
ASL	50-ASD	502 & 504	814 & 816	—
ASM	50-ASD	506 & 508	818	
ASM	50-AD	—	—	1816 & 1818 & 1822



CAUTION
Wear safety glasses.

1. Push TENSION CONTROL HANDLE (KEY #5) forward to its detent position. This will raise the FEEDWHEEL (KEY #26) for strap insertion. (SEE FIGURE NO. 1.)

2. Encircle the package with the strap. Depress and hold GRIPPER LEVER (KEY #60). Insert bottom strap lead end under the FEEDWHEEL (KEY #26) beyond the STRAP GUIDE (KEY #40), with the back portion underneath the STRAP GRIPPER (KEY #59). Release GRIPPER LEVER (KEY #60) to hold bottom strap in place. (SEE FIGURE NO. 2.)

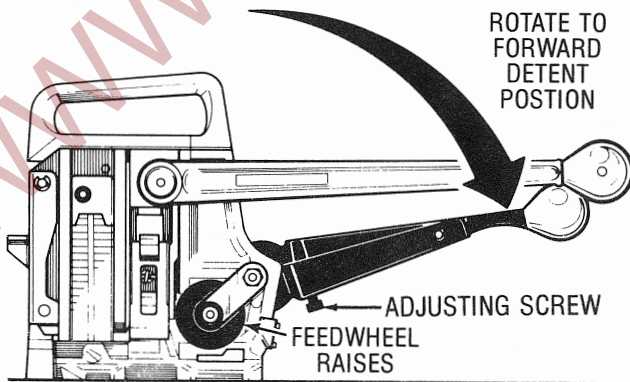

FIGURE NO. 1

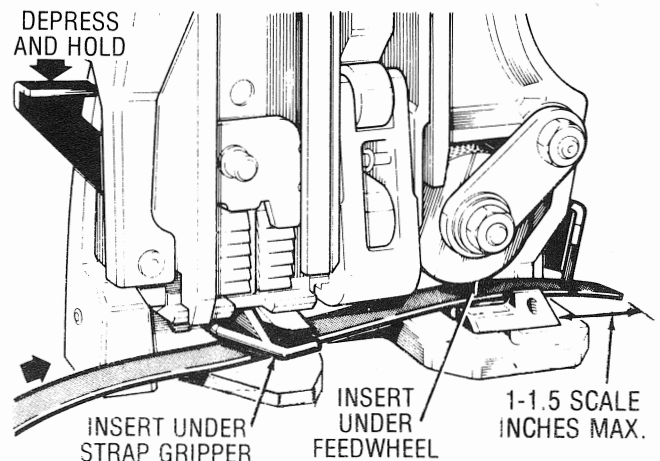

FIGURE NO. 2

OPERATING INSTRUCTIONS (continued)

3. Insert the top strap beneath the FEEDWHEEL (KEY #26) and into the strap slot of the CUTTER BLOCK (KEY #66). Pull excess slack from the strap. (SEE FIGURE NO. 3.)

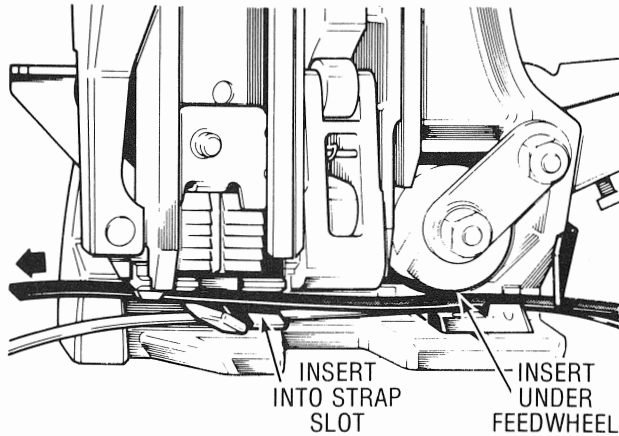

FIGURE NO. 3

4. Hold tool by the TOP HANDLE (KEY #1), move TENSION CONTROL HANDLE (KEY #5) toward operator to lower FEEDWHEEL (KEY #26). Continue pulling TENSION CONTROL HANDLE (KEY #5) to the rear to apply tension onto strap. Return TENSION CONTROL HANDLE (KEY #5) forward and repeat the action until the TENSION CONTROL HANDLE (KEY #5) deflects and is stopped from further movement. This indicates that the factory pre-set tension has been reached. (SEE FIGURE NO. 4.)

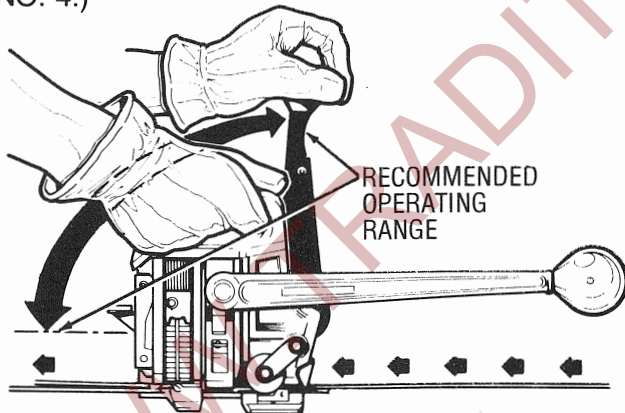

FIGURE NO. 4



CAUTION:

DO NOT ROTATE THE TENSION CONTROL HANDLE TOO FAR FORWARD AS A SUDDEN RELEASE OF TENSION COULD OCCUR. FIGURE NO. 4 SHOWS TENSION CONTROL HANDLE IN ITS RECOMMENDED FURTHEST FORWARD POSITION.

NOTE:

Setting of the ADJUSTING SCREW (KEY #9) de-

termines tension level at which TENSION CONTROL HANDLE (KEY #5) will be stopped. Higher tension can be achieved by turning the ADJUSTING SCREW (KEY #9) clockwise.

5. After the desired tension is reached, complete the sealing and cutoff operation by pulling the SEALER HANDLE (KEY #76) to the rear stop position. (SEE FIGURE NO. 5.)

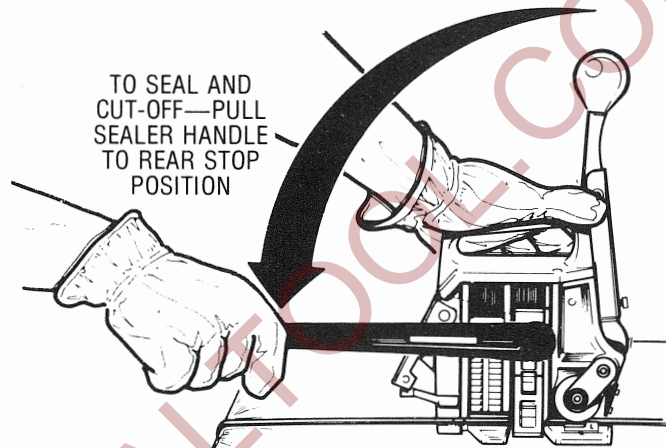

FIGURE NO. 5

The SEALER HANDLE (KEY #76) is then returned to the forward stop position, which will raise the sealing mechanism and feed a new seal into the jaws. (SEE FIGURE NO. 6.)

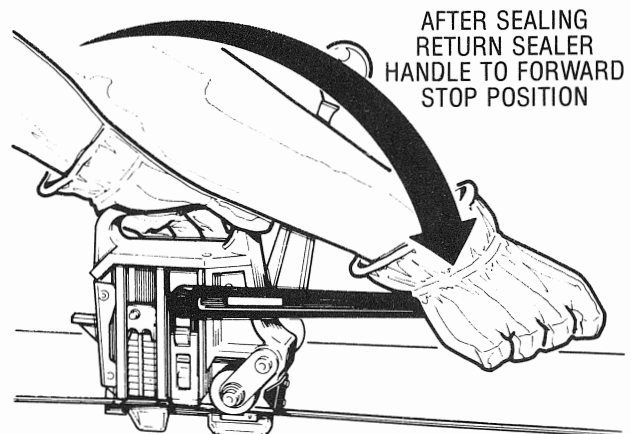
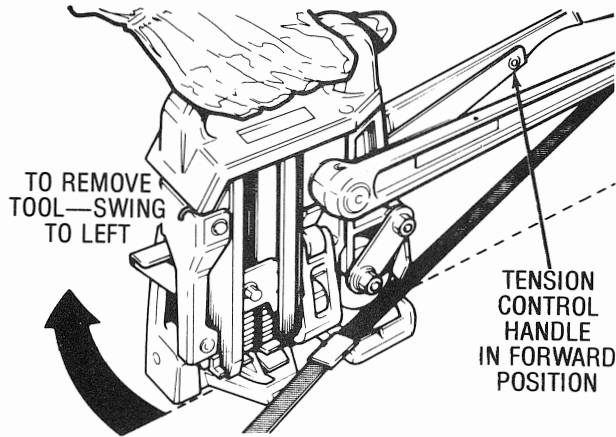

FIGURE NO. 6

NOTE:

To assure that proper joint strength is obtained, this tool features a sure-seal mechanism which prevents removal of the tool until the sealing action is completed. If the SEALER HANDLE (KEY #76) cannot be returned past its vertical position, the sealing stroke was not completed. Rotate the SEALER HANDLE to the rear stop position to complete the sealing cycle.

- To remove the tool from the strap, return the TENSION CONTROL HANDLE (KEY #5) to the forward detent position, hold tool by the TOP HANDLE (KEY #1) and swing the rear of the tool to the operator's left until it is free of the strap.



LOADING SEALS

To load seals, raise SEAL PAD ASSEMBLY (KEY #69) and insert stack of seals through opening in side of Seal Magazine. Make sure seal stack is properly seated on the CUTTER BLOCK (KEY #66).

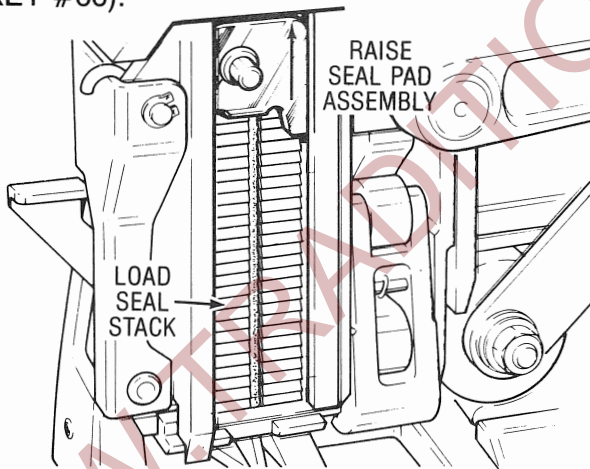

PARTS REPLACEMENT

Key numbers refer to exploded views (Pages 8 to 13).

To replace STRAP GRIPPER (KEY #59), CUTTER BLOCK (KEY #66), MAGAZINE SPRING (KEY #71), CUTTER BLADE (KEY #85), RETAINING CLIP SPRING (KEY #96) or any parts of the sealing mechanism, remove three SOCKET HEAD CAP SCREWS (KEY #2), TOP HANDLE (KEY #1), SOCKET HEAD SHOULDER BOLT (KEY #62) and SOCKET HEAD CAP SCREW (KEY #63).

Tilt top of magazine at back of tool and pull out. Lift out sealing mechanism. When installing the magazine, the sealing mechanism must be in the raised position and ROLLER GUIDE (KEY #86) properly located.

To replace FEEDWHEEL (KEY #26), remove LOCK NUT (KEY #13) on SUPPORT SHAFT (KEY #17), HEX NUT LEFT HAND (KEY #22), WASHER (KEY #23) and OUTERLINK (KEY #25) and pull out the FEEDWHEEL (KEY #26).

To replace GRIPPER PLUG (KEY #44), remove two FLAT HEAD SOCKET SCREWS (KEY #43), SIDE GUIDE (KEY #42) and PIVOT PIN (KEY #45) and push the GRIPPER PLUG (KEY #44) upward.

ADJUSTMENT

Key numbers refer to exploded views (Pages 8 to 13).

If CUTTER on tool does not cut strap properly, loosen SOCKET HEAD CAP SCREWS (KEYS #62 and 63) and place SEALING HANDLE in vertical position. Adjust SET SCREW (KEY #39) to take up clearance between CUTTER BLADE (KEY #85) and CUTTER BLOCK (KEY #66). Sealer mechanism must not bind after adjustment. Retighten SOCKET HEAD CAP SCREWS (KEYS #62 and 63).

Tools should be kept clean and all moving parts should be lubricated with a light machine oil weekly.

Clean teeth of FEEDWHEEL (KEY #26) and GRIPPER PLUG (KEY #44) with the BRUSH (PART NO. 023963) provided with the tool.

PARTS LIST

Model ASL—Part #010100
Model ASM—Part #164621

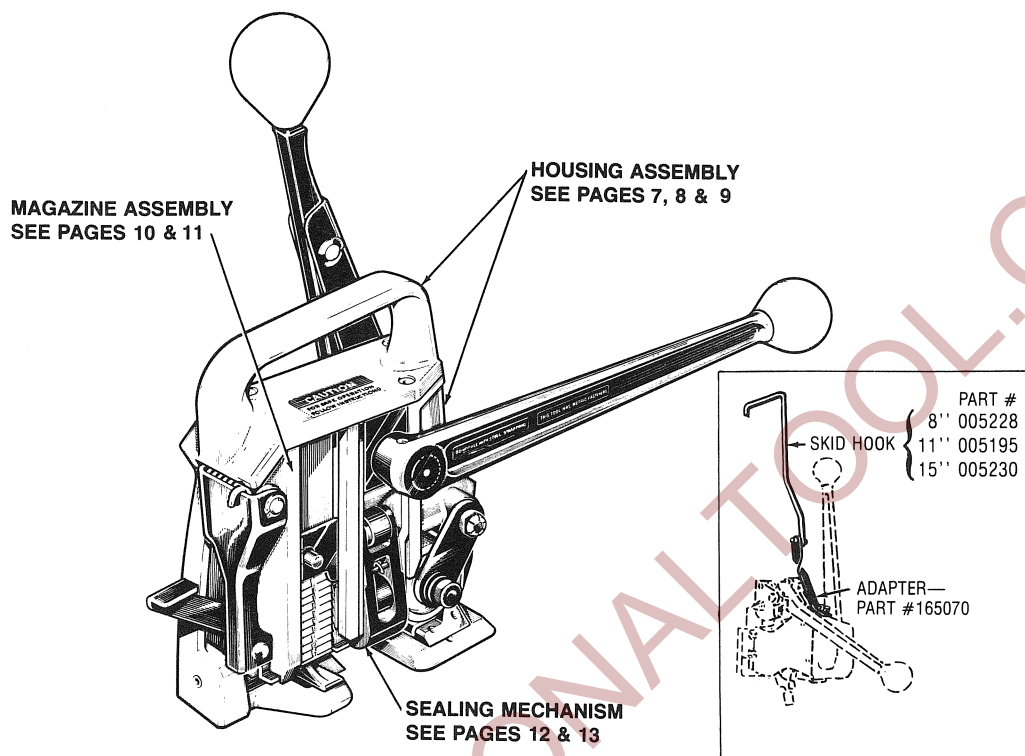

WEARING PARTS ARE USUALLY LIMITED TO THOSE UNDERLINED. WHEN ORDERING PARTS PLEASE SHOW TOOL MODEL, PART NUMBER AND PART NAME. HARDWARE SIZES LISTED MAY BE OBTAINED AT A LOCAL HARDWARE

NOTES:

- A. Apply one drop of "Loctite #242" sealant to cleaned parts. Allow 12 hours to set if possible. Do not apply close to moving parts as liquid spreads easily.
- B. Apply one drop of "Loctite #271" sealant to cleaned parts. Allow 12 hours to set if possible. Do not apply close to moving parts as liquid spreads easily.
- C. Assemble with point towards housing.
- D. Adjust to take up clearance between cutter blade. Sealer mechanism must not bind after adjustment.
- E. Pin must be flush to 0.5mm below seal surface of magazine.
- F. Detent can be riveted apart from housing and pressed in from back side as a sub-assembly.
- G. Install grooved pin flush with outside surface of housing.
- H. Directional clip — assemble as shown.
- J. Press sleeve flush to 0.3mm above inside machined boss surface.

MAGAZINE ASSEMBLY

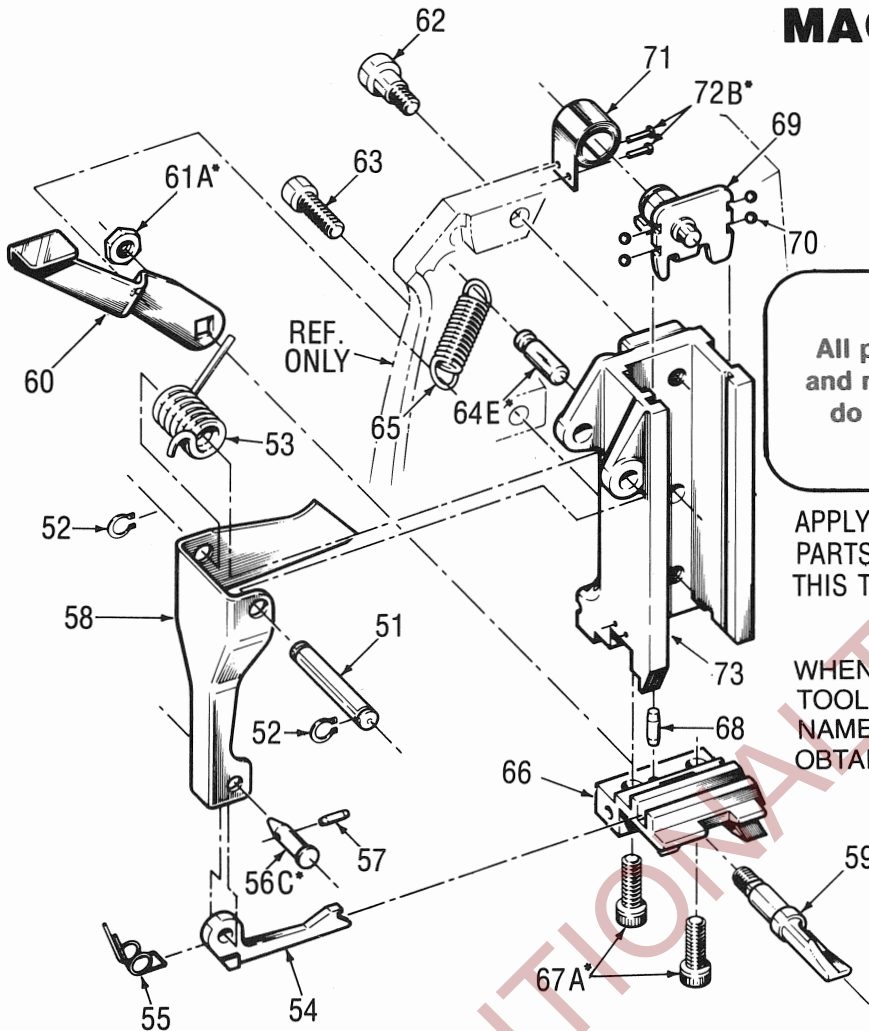

WARNING
 All parts must be periodically inspected and replaced if worn or broken. Failure to do this can affect the tool's operation and present a safety hazard.

APPLYING LIGHT MACHINE OIL TO ALL MOVING PARTS WILL INCREASE THE SERVICE LIFE OF THIS TOOL.

WHEN ORDERING PARTS PLEASE SHOW TOOL MODEL, PART NUMBER AND PART NAME. HARDWARE SIZES LISTED MAY BE OBTAINED AT A LOCAL HARDWARE SUPPLY.

- Metric sizes are in millimeters.
- ∅ Diameter symbol.
- M Denotes SI metric thread.

KEY NO.	PART NAME	QTY.	MODEL ASL	MODEL ASM
51	Ejector Arm Pin	1	020622	-----
52	Retaining Ring (Truarc #5100-31)	2	005054	-----
53	Ejector Arm Spring	1	020664	-----
54	Ejector	1	024415	-----
55	Ejector Spring	1	020629	-----
56	Ejector Pin	1	020621	-----
57	Roll Pin 1/8" Dia. x 3/8" Lg.	1	006045	-----
58	Ejector Lever	1	010106	-----
59	Strap Gripper	1	010112	-----
60	Gripper Lever	1	010108	-----
61	• Low Hex Nut M8	1	171807	-----
62	• Socket Head Shoulder Bolt M6 x 12 Lg.	1	164956	-----
63	• Socket Head Cap Screw M8 x 25 Lg.	1	162403	-----
64	Grooved Pin 5/16" Dia. x 7/8" Lg. Type "G"	1	002395	-----
65	Gripper Spring	1	010109	-----
66	Cutter Block	1	010165	-----
67	• Socket Head Cap Screw M8 x 20 Lg.	2	160331	-----
68	• Dowel Pin ∅4 x 20 Lg.	1	160328	-----
69	Seal Pad Assembly	1	024708-A	-----
70	Steel Balls 1/8" Dia.	4	024723	-----
71	Magazine Spring	1	020640	-----
72	Drive Screw #2 x 3/16" Lg.	2	004939	-----
73	Magazine	1	010121	-----

*SEE ADJACENT PAGE FOR NOTES.

MAGAZINE ASSEMBLY

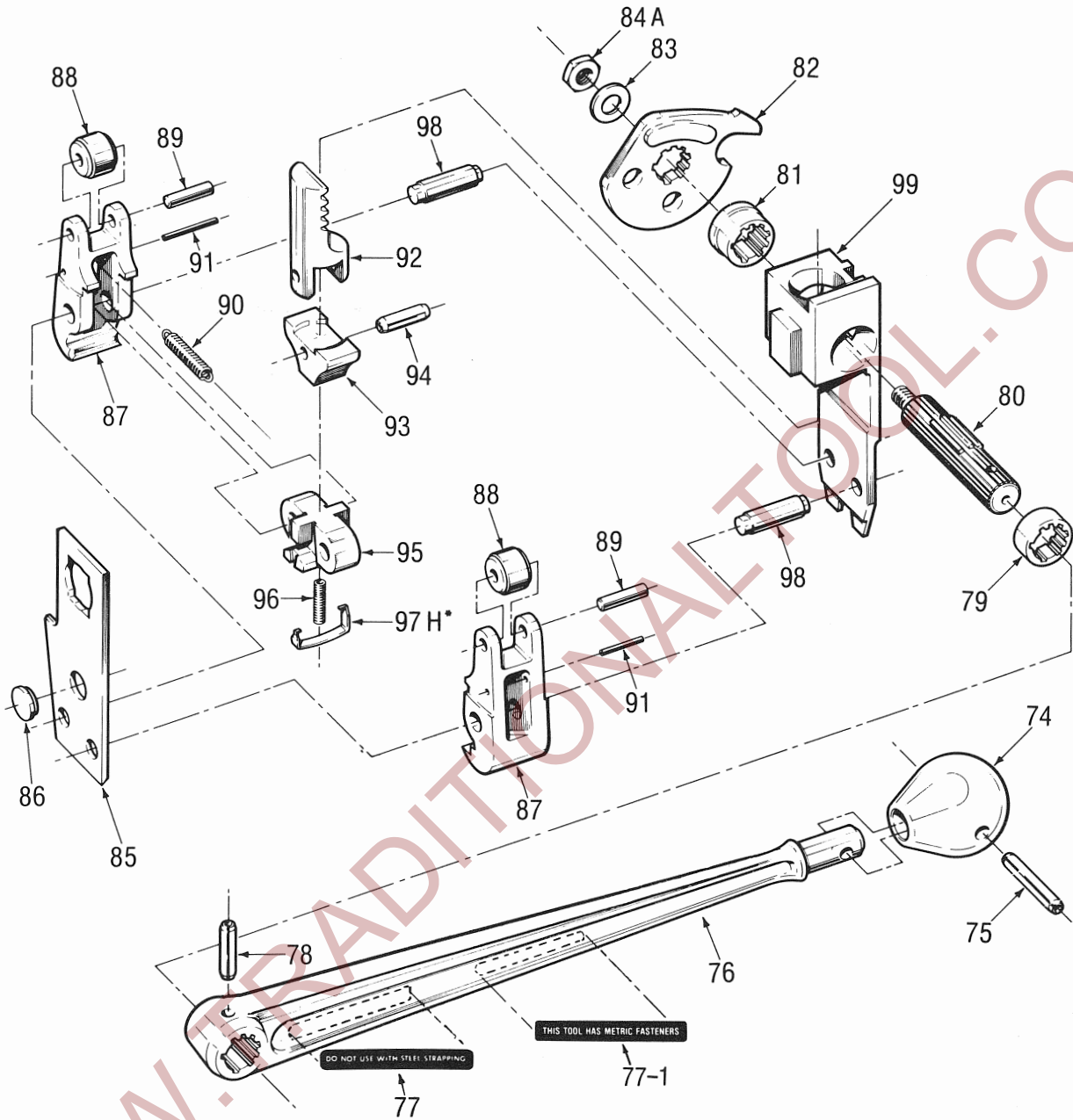

APPLYING LIGHT MACHINE OIL TO ALL MOVING PARTS
WILL INCREASE THE SERVICE LIFE OF THIS TOOL.

*SEE ADJACENT PAGE FOR NOTES.

MAGAZINE ASSEMBLY PARTS LIST

KEY NO.	PART NAME	QTY.	MODEL ASL	MODEL ASM
74	Knob	1	010054	_____
75	Roll Pin 1/4" Dia. x 1 3/4" Lg.	1	010057	_____
76	Sealer Handle	1	171800	_____
77	Warning Plate	1	023962	_____
77-1	Information Sign	1	180900	-----
78	Roll Pin 1/4" Dia. x 1" Lg.	1	010023	_____
79	Short Pinion Bearing	1	010156	_____
80	Sealer Pinion	1	010119	_____
81	Sealer Pinion Bearing	1	010158	_____
82	Sealer Cam	1	010148	_____
83	Flat Washer	1	170875	_____
84	• Low Hex Nut M10 x 1	1	170873	_____
85	Cutter Blade	1	010113	_____
86	Roller Guide	1	164619	_____
87	Jaw	2	010159	_____
88	Cam Roller	2	002394	_____
89	• Dowel Pin \varnothing 6 x 24 Lg.	2	160329	_____
90	Jaw Return Spring	1	010150	_____
91	• Roll Pin \varnothing 3 x 24 Lg.	2	160322	_____
92	Rack	1	010157	_____
93	Cam	1	010149	_____
94	• Roll Pin \varnothing 6 x 24 Lg.	1	005461	_____
95	Chair	1	010151	164622
96	<u>Retaining Clip Spring</u>	1	074391	_____
97	<u>Seal Retaining Clip</u>	1	024408	_____
98	<u>Jaw Pin</u>	2	010152	_____
99	Jaw Support	1	010155	_____
	Brush (Not Illustrated)	1	023963	_____

Wearing parts are usually limited to those underlined.

- Metric sizes are in millimeters.
- \varnothing Diameter symbol.
- M Denotes SI metric thread.



WARNING

All parts must be periodically inspected and replaced if worn or broken. Failure to do this can affect the tool's operation and present a safety hazard.

WHEN ORDERING PARTS PLEASE SHOW TOOL MODEL, PART NUMBER AND PART NAME. HARDWARE SIZES LISTED MAY BE OBTAINED AT A LOCAL HARDWARE SUPPLY.

NOTES:

- A. Apply one drop of "Loctite #242" sealant to cleaned parts. Allow 12 hours to set if possible. Do not apply close to moving parts as liquid spreads easily.
- B. Apply one drop of "Loctite #271" sealant to cleaned parts. Allow 12 hours to set if possible. Do not apply close to moving parts as liquid spreads easily.
- C. Assemble with point towards housing.
- D. Adjust to take up clearance between cutter blade. Sealer mechanism must not bind after adjustment.
- E. Pin must be flush to 0.5mm below seal surface of magazine.
- F. Detent can be riveted apart from housing and pressed in from back side as a sub-assembly.
- G. Install grooved pin flush with outside surface of housing.
- H. Directional clip — assemble as shown.
- J. Press sleeve flush to 0.3mm above inside machined boss surface.

PARTS LIST (continued)

HOUSING ASSEMBLY

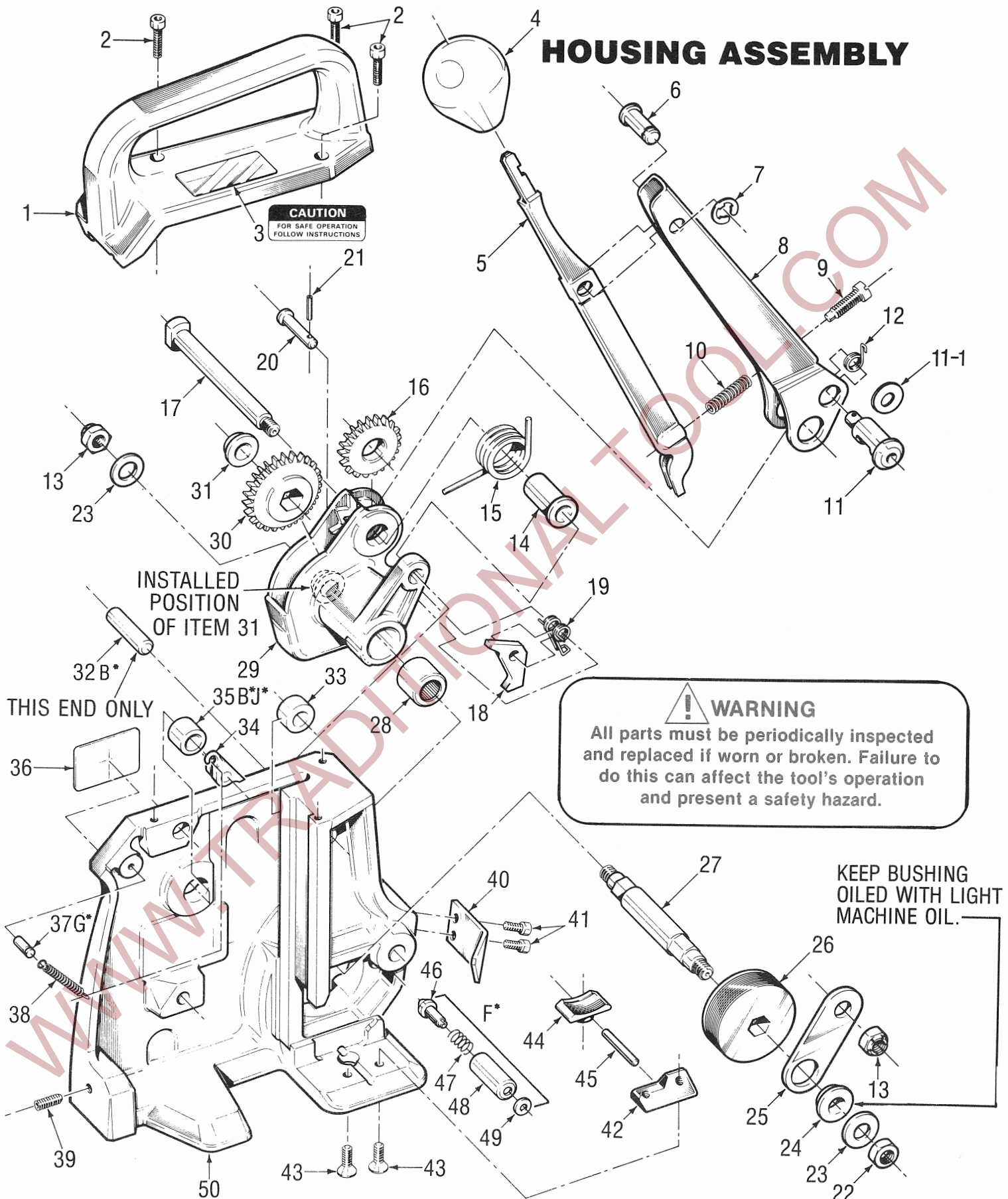

CAUTION
FOR SAFE OPERATION
FOLLOW INSTRUCTIONS

WARNING
All parts must be periodically inspected and replaced if worn or broken. Failure to do this can affect the tool's operation and present a safety hazard.

KEEP BUSHING OILED WITH LIGHT MACHINE OIL.

NOTE: KEY #22 LEFT HAND THREAD

*SEE PRECEDING PAGE FOR NOTES.

HOUSING ASSEMBLY PARTS LIST

KEY NO.	PART NAME	QTY.	MODEL ASL	MODEL ASM
1	Top Handle	1	010105	_____
2	● Socket Head Cap Screw M5 x 16 Lg.	3	011214	_____
3	Caution Plate	1	003132	_____
4	Knob	1	008648	_____
5	Tension Control Handle	1	010146	_____
6	Handle Pivot Pin	1	010147	_____
7	Retaining Ring Truarc #11-420-0100)	1	171809	_____
8	Upper Handle	1	010137	_____
9	Adjusting Screw	1	010136	_____
10	Tension Control Spring	1	010125	_____
11	Driving Pawl	1	010132	_____
11-1	Retaining Washer	1	180661	_____
12	Driving Pawl Spring	1	010133	_____
13	● Lock Nut M8	2	005467	_____
14	Pinion Bearing	1	010138	_____
15	Energizing Spring	1	010118	_____
16	Tensioner Pinion	1	010140	_____
17	Support Shaft	1	010139	_____
18	Holding Pawl	1	164620	_____
19	Holding Pawl Spring	1	010141	_____
20	Pawl Pin	1	010142	_____
21	● Roll Pin \varnothing 3 x 10 Lg.	1	160318	_____
22	● Hex Nut M8 Left Hand	1	170874	_____
23	Washer	2	171808	_____
24	<u>Bushing</u>	1	010160	_____
25	Outerlink	1	010117	_____
26	<u>Feedwheel</u>	1	010116	_____
27	Feedwheel Shaft	1	010122	_____
28	Roller Bearing	1	164624	_____
29	Gear Housing	1	010161	_____
30	Tension Gear	1	010143	_____
31	Gear Housing Bearing	1	010131	_____
32	● Dowel Pin \varnothing 10 x 30 Lg.	1	160330	_____
33	Roller (Sealer Cam)	1	010134	_____
34	Pawl (Sure Seal)	1	002392	_____
35	Sleeve (Sure Seal)	1	002396	_____
36	Name Plate	1	010145	164623
37	Grooved Pin 5/32" Dia. x 1/2" Lg. Type "G"	1	160319	_____
38	Sure Seal Spring	1	164616	_____
39	● Socket Head Set Screw (Flat Point, Longlok)			
	M6 x 16 Lg.	1	177721	_____
40	Strap Guide	1	010135	_____
41	● Socket Head Cap Screw M5 x 8 Lg.	2	164618	_____
42	Side Guide	1	010124	_____
43	● Flat Head Socket Cap Screw M5 x 14 Lg.	2	174651	_____
44	<u>Gripper Plug</u>	1	010114	_____
45	<u>Pivot Pin</u>	1	010115	_____
46	Detent Plunger	1	010129	_____
47	Detent Spring	1	005165	_____
48	Detent Housing	1	010127	_____
49	Stop Washer	1	010126	_____
50	Housing	1	010103	_____

Wearing parts are usually limited to those underlined.

● Metric sizes in millimeters.

\varnothing Diameter symbol.

M Denotes SI metric thread.

WWW.TRADITIONALTOOL.COM