

OPERATION, PARTS AND SAFETY MANUAL

SIGNODE®

SYC and C

HEAVY DUTY MANUAL SEALERS

**IMPORTANT!
DO NOT DESTROY**

**It is the customer's responsibility to
have all operators and servicemen
read and understand this manual.**

**Contact your local Signode representative
for additional copies of this manual.**

READ ALL INSTRUCTIONS BEFORE OPERATING THIS SIGNODE PRODUCT



SAFETY INSTRUCTIONS

READ THESE INSTRUCTIONS CAREFULLY.
FAILURE TO FOLLOW THESE INSTRUCTIONS CAN RESULT IN SEVERE PERSONAL INJURY.

GENERAL SAFETY CONSIDERATIONS

1. EYE INJURY HAZARD.

Failure to wear safety glasses with side shields can result in severe eye injury or blindness. Always wear safety glasses with side shields which conform to ANSI Standard Z87.1.



2. FALL HAZARD.

Maintaining improper footing and/or balance when operating the tool can cause you to fall. Do not use the tool when you are in an awkward position.

3. CUT HAZARD.

Handling strap or sharp parts could result in cut hands or fingers. Wear protective gloves.

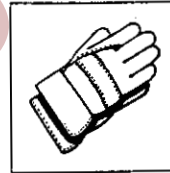

4. TRAINING.

This tool must not be used by persons not properly trained in its use. Be certain that you receive proper training from your employer. If you have any questions contact your Signode Representative.

5. TOOL CARE.

Take good care of the tool. Inspect and clean it daily, lubricate it weekly. Replace any worn or broken parts.

6. WORK AREA.

Keep work areas uncluttered and well lighted.

7. TENSIONING STRAP.

When tensioning strap use proper tensioner for specific strap sizes. Read the tensioner's operation and safety manual.

Several combinations of strap, seals and tools can be used with this tensioner. Use the correct Signode products for your application. If you need help contact your Signode Representative.

SAFETY PROCEDURES FOR TOOL OPERATION

1. Before using this sealer, read all the instructions in this Operation, Parts and Safety Manual.
2. Always lift and carry the tool by the tool handle. Lifting the tool at any other point may expose the hand to a 'pinch point'.
3. Make sure the sealer jaws are placed directly on the seal.
4. While sealing, position yourself to one side of the tensioned strap.
5. This tool is a single notch sealer that requires two sealing operations for each seal. A properly notched seal will appear as shown in the illustration. If the notched seal does not appear as shown, inspect the tool for worn and/or damaged parts. Replace tool parts as needed. Do not ship any loads secured with improperly notched seals. Seals must be properly notched.

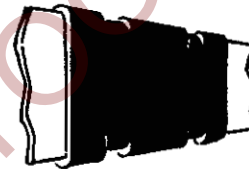

CUTTING TENSIONED STRAP

FLYING STRAP HAZARD.

Using claw hammers, crowbars, chisels, axes or similar tools will cause tensioned strap to fly apart with hazardous force. Use only cutters designed for cutting strap. Read the instructions in the cutters manual for proper procedure in cutting strap. Before using any Signode product read its Operation and Safety Manual.

Safety instructions in Spanish are available from your Signode Sales Representative.

Su vendedor Signode le puede proporcionar los instructivos de seguridad en español.

TABLE OF CONTENTS

General Safety Instructions	2
Specifications	4
Operating Instructions	5
Maintenance	5
Parts List	6



SYC-3435
Part No. 004040

C-1435
Part No. 003970

C-1450
Part No. 003990

SPECIFICATIONS

		STRAP		
MODEL	TYPE	WIDTH	THICKNESS	SEALS
SYC-3435	Magnus	3/4"	.025 TO .031	34HC, HC-OF, HOC, I, SHOC
C-1435		1 1/4"	.031 to .035	114, I, OF, P, SP
C-1450			.044	

OPERATING INSTRUCTIONS

WARNING

Wear safety glasses which conform to ANSI Standard Z87.1. Position yourself to one side of the tensioned strap while sealing. Maintain proper footing and balance.

1. Fully open sealer handles and center the open jaws to one end of the seal.

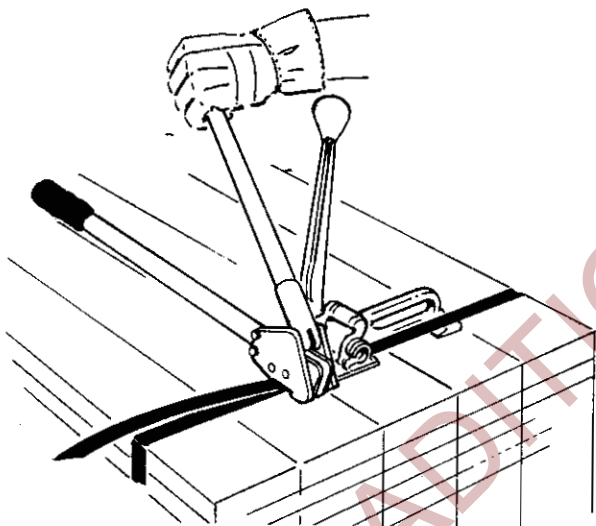

2. Bring the sealer handles completely together to assure a proper notch.

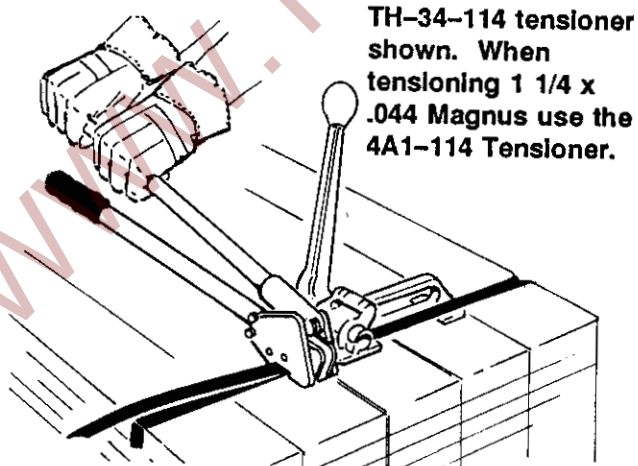

TH-34-114 tensioner shown. When tensioning 1 1/4 x .044 Magnus use the 4A1-114 Tensioner.

3. Remove the sealer. Place the sealer on the opposite end of the seal and bring the handles completely together. Remove the sealer. Inspect the joint to make sure the sealer has properly notched the seal and strap. If possible, cut the strap end by bending the strap back and forth until it breaks off flush with the seal, otherwise, cut the strap with an approved Signode strap cutter.
4. To avoid contact with the sharp end of the strap, retract strap end back into the strap dispenser.

MAINTENANCE

1. Inspect the tool before use for worn or broken parts. Replace parts if necessary.
2. Clean the tool and apply light machine oil to all moving parts on a weekly basis.

PARTS LIST

KEY	QTY.	SYC-3435 PART NO.	C-1435 PART NO.	C-1450 PART NO.	DESCRIPTION
1	3	003911	003911	003911	Flexloc nut, thin, 5/16-24
2	2	004033	003992	003971	Side plate
3	4	<u>004037</u>	<u>003974</u>	<u>003974</u>	<u>Jaw pin</u>
4	4	<u>004039</u>	<u>003977</u>	<u>003977</u>	<u>Jaw</u>
5	2	<u>004038</u>	<u>003976</u>	<u>003976</u>	<u>Notcher pin</u>
6	2	<u>004041</u>	<u>003978</u>	<u>003991</u>	<u>Notcher</u>
7	1	004035	003975	003988	Upper handle assembly
8	4	004036	003973	003973	Link pin
9	1	003907	003907	003907	Rear link
10	1	003906	003906	003906	Front link
11	3	<u>004034</u>	_____	_____	Hex head cap screw, 5/16-24 x 1 7/16
	3	_____	003972	003972	Hex head cap screw, 5/16-24 x 1 5/8
12	2	082630	082630	082630	Grip
13	1	004045	003980	003989	Lower handle arm assembly
14	1	003132	003132	003132	Caution plate
15	1	002480	002480	002480	Nameplate
16	2	002163	002163	002163	Drive screw

When ordering parts, please show tool model, part number and description.
 All recommended spare parts are underlined and should be stocked.
 Standard hardware parts may be obtained at any local hardware supply.

