

### T TENSIONER PARTS LIST

KEY	QTY.	PART #	DESCRIPTION
1	1	003463	Handle
2	1	010054	Knob (Old style)
	1	306927	Knob (New style)
3	1	010057	Roll pin
4	1	003462	Handle pawl
5	1	003467	Handle pawl spring
6	1	003464	Handle pawl pin
7	1	003458	Ratchet gear
8	1	003460	Feedwheel support
9	1	003457	Feedwheel shaft
10	1	003478	Bearing
11	1	004502	SHCS, 10-32 x 5/8
12	1	003452	Feedwheel
13	1	003461	Support pin
14	1	003459	Support spring
15	1	003456	Retaining pawl pin
16	2	003483	Retaining pawl spring
17	1	003454	Long retaining pawl
18	1	003455	Short retaining pawl
19	2	001656	Strap guide pin
20	1	273748	Clutch plug assembly
21	1	001644	Lock wire
22	1	003133	Caution sign
23	1	002598	Nameplate
24	1	003451	Base
25	1	306544	Handle assembly

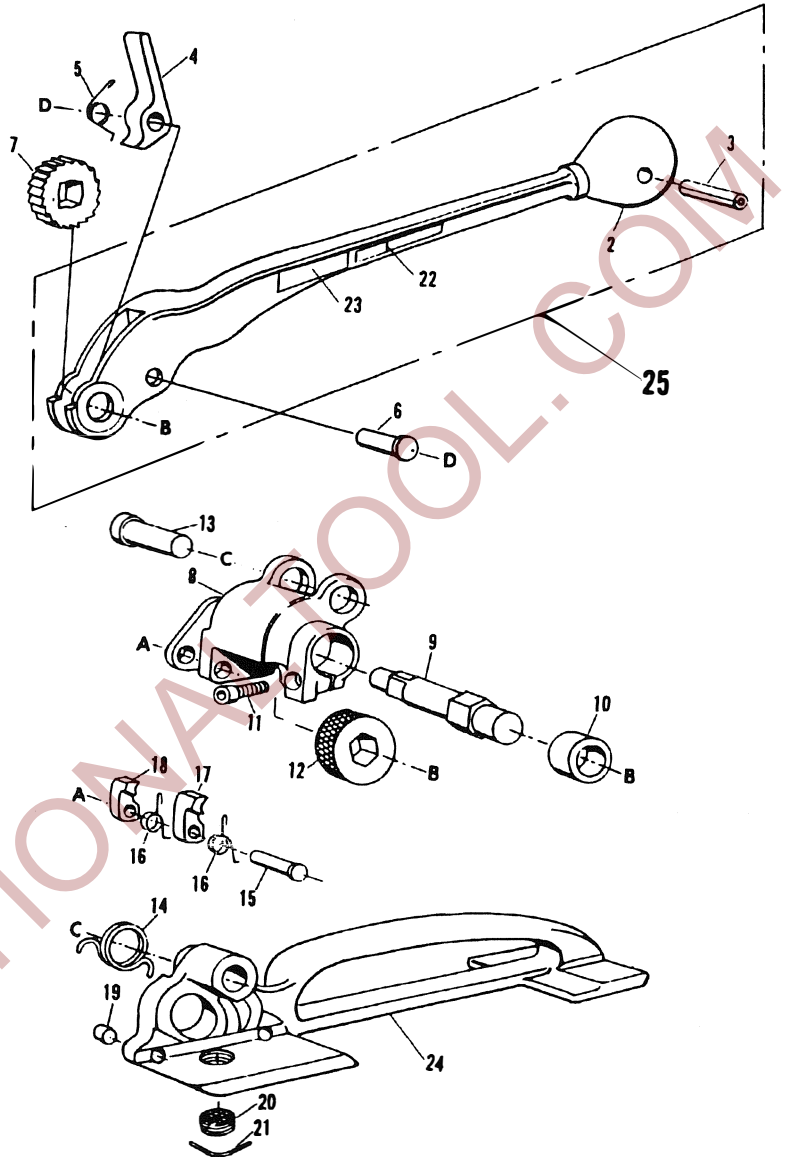

When ordering parts, please show tool model, part number, and description.

All recommended spare parts are underlined and should be stocked.

**WARNING** All parts must be periodically inspected and replaced if worn or broken. Failure to do this can affect a product's operation and can result in personal injury.

### CLUTCH PLUG ADJUSTMENT

1. Remove the lock wire (Key 21) with needle nose pliers.
2. Using a flat head screwdriver, tighten the clutch plug (20) so that it touches the feedwheel. Then back it off one groove to align it with the lock wire holes in the tool base. Be sure the clutch plug and the feedwheel do not touch.
3. Replace the lock wire over the grooves in the clutch plug and hammer flat. To be sure the lock wire is secure, place a screwdriver across the center of the lock wire and tap once more.

NOTE: Inspect your tool for the proper Knob (Key No. 2) used on the handle assembly. The older style Knob will have a round mounting hole and the newer style will have a rectangular mounting hole.

OLD STYLE  
PART NO.  
010054

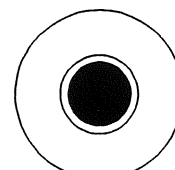

ROUND

NEW STYLE  
PART NO.  
306927

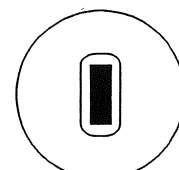

RECTANGULAR

