

OPERATION, PARTS AND SAFETY MANUAL

It is the customer's responsibility to have all operators and servicemen read and understand this manual.

TH-114 STRAP TENSIONER

Part No. 020500



TOOL SPECIFICATIONS

STRAP TYPE	WIDTH	THICKNESS
Apex, Magnus	1-1/4"(32.0mm)	.029"(0.73mm) to .035"(0.89mm)

IMPORTANT - DO NOT DESTROY THIS MANUAL. It is the customer's responsibility to have all operators and service personnel read and understand this manual. Contact your local Signode representative for additional copies of this manual.

SAFETY INSTRUCTIONS

**GENERAL SAFETY INSTRUCTIONS - READ THESE INSTRUCTIONS CAREFULLY.
FAILURE TO FOLLOW THESE INSTRUCTIONS CAN RESULT IN SEVERE PERSONAL INJURY.**

GENERAL CONSIDERATIONS

1. EYE INJURY HAZARD.

Failure to wear safety glasses with side shields can result in severe eye injury or blindness. Always wear safety glasses with side shields which conform to ANSI Standard Z87.1 or EN 166.



2. STRAP BREAKAGE HAZARD.

Improper operation of the tool or sharp corners on the load can result in strap breakage during tensioning, which could result in the following:

! A sudden loss of balance causing you to fall.

! Both tool and strap flying violently towards your face.

Failure to place the strap properly around the load or on an unstable or shifted load could result in a sudden loss of strap tension during tensioning. This could result in a sudden loss of balance causing you to fall.

Read the tools operating instructions. If the load corners are sharp use edge protectors. Place the strap correctly around a properly positioned load.

! Positioning yourself in-line with the strap, during tensioning and sealing, can result in severe personal injury from flying strap or tool. When tensioning or sealing, position yourself to one side of the strap and keep all bystanders away.

! Using strap not recommended for this tensioner can result in strap breakage during tensioning. Use the correct Signode products for your application.

3. FALL HAZARD.

Maintaining improper footing and/or balance when operating the tool can cause you to fall. Do not use the tool when you are in an awkward position.

4. CUT HAZARD

Always wear protective gloves when handling strap or sharp parts.



5. TRAINING.

This tool must not be used by persons not properly trained in its use. Be certain that you receive proper training from your employer. If you have any questions contact your Signode Representative.

6. TOOL CARE.

Take good care of the tool. Inspect and clean it daily, lubricate it weekly. Replace any worn or broken parts.

7. WORK AREA

Keep work areas uncluttered and well lit.

8. CUTTING TENSIONED STRAP

Using claw hammers, crowbars, chisels, axes or similar tools will cause tensioned strap to fly apart with hazardous force. Use only cutters designed for cutting strap. Read the instructions in the cutters manual for proper procedure in cutting strap. Before using any Signode product read its operation and safety manual.

Several combinations of strap and tools can be used with this tensioner. Use the correct Signode products for your application. If you need help contact your Signode Representative.

SAFETY PROCEDURES FOR TOOL OPERATION

1. Before using this tensioner, read all the instructions in this Operation, Parts and Safety Manual.

2. **NEVER HANDLE OR SHIP ANY LOAD WITH IMPROPERLY FORMED SEALS.** Misformed seals may not secure the load and could cause serious injury. Inspect the tool for worn and/or damaged parts. Replace tool parts as needed.

If seals are not being properly formed:

A. Ensure that the tool's operating instructions are being followed before applying another strap.

B. Cut the strap off and apply another.

3. Tuck strap end back into the dispenser when not in use.

MAINTENANCE/CLEANING

Debris accumulated in the teeth of either the feedwheel or the clutch plug must be removed with a small wire brush. A need to clean the teeth will become apparent when either the feedwheel skids on the strap or the lower strap slips on the clutch plug during tensioning.

OPERATING INSTRUCTIONS

⚠ WARNING

Wear safety glasses which conform to ANSI Standard Z87.1 or EN 166.

Always position yourself to one side of the strap while tensioning and sealing. Make sure all bystanders are clear before proceeding. Maintain proper footing and balance.

1. Encircle the package with strap as illustrated. Take up the slack, keeping the strap squarely in line.

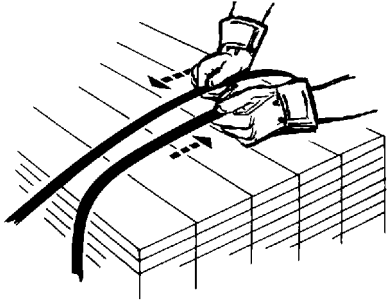

2. Squeeze the tension handle to the base to lift the feedwheel and apply the tool to both layers of strap.

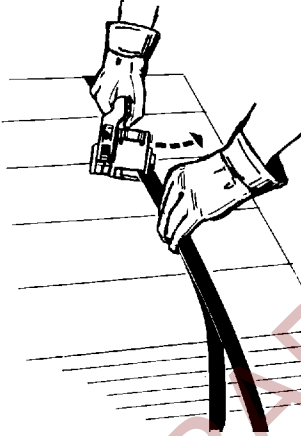

3. While standing to one side of the strap line, tension the strap through continuous up and down motions with the tensioning handle. **NOTE:** Do not allow the handle to press against the base during the downward portion of the tensioning cycle. This will raise the feedwheel and release the tensioned strap.

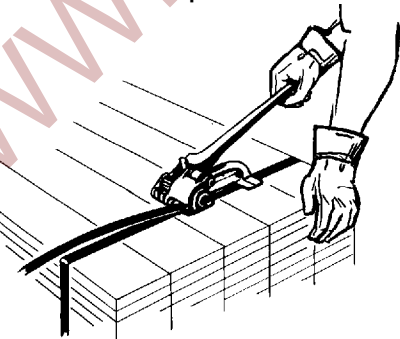

4. Snap a seal on the straps directly in front of the tool, making sure that the seal covers both straps.

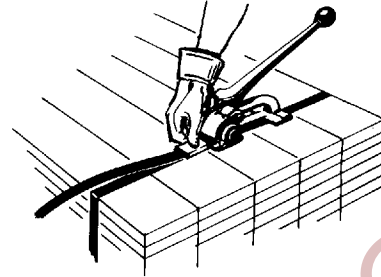

5. Crimp or notch the seal as shown.

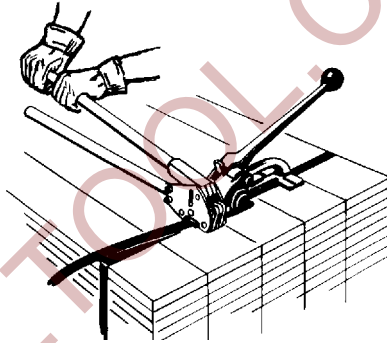

6. Press and hold the handle pawl with thumb. Squeeze the handle to the base and remove the tool from the strap by swinging the rear foot out as illustrated.

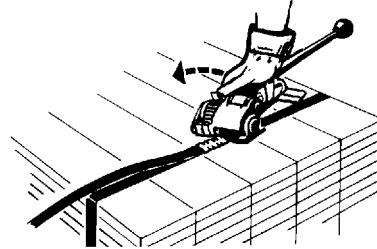

7. Excess strap is bent sharply back on the seal with the thumb or fingers. Several additional bends will result in a clean strap break off. If the width and gauge of the strap being used will not allow it to be bent, cut the excess strap as close to the seal as possible using an approved strap cutter. Inspect the joint to make sure the seal has been properly notched or crimped (Refer to the sealer manual).

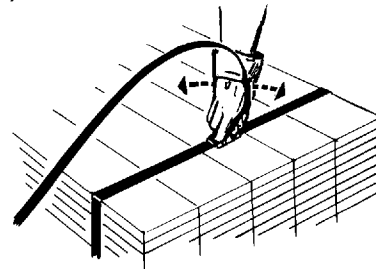

TH-114 TENSIONER PARTS LIST

KEY	QTY.	PART #	DESCRIPTION
1	1	020503	Handle
2	1	010054	Knob
3	1	010057	Roll pin
4	1	020512	Handle pawl
5	1	020511	Handle pawl spring
6	1	007507	Cross head pin
7	1	020510	Ratchet gear
8	1	020502	Support frame
9	1	020504	Feedwheel shaft
10	1	020506	Bushing
11	1	023080	Roll pin, 3/16 x 7/8
12	1	424034	Feedwheel
13	1	020505	Strap spacer
14	1	020509	Support pin
15	1	008671	Retaining ring
16	1	020508	Retaining spring
17	1	020570	Feedwheel spring
18	1	020516	Retaining pawl pin
19	2	003483	Pawl spring
20	1	020514	Long pawl
21	1	020515	Short pawl
22	1	020507	Clutch plug
23	1	003133	Caution sign
24	1	020501	Base
25	1	015747	SHSS, 1/4-28 x 5/8, flat point
26	1	002431	Nameplate
27	2	002163	Drive screw (Black)
28	1	424270	Hex nut, steel
29	1	424250	Bushing
30	1	424251	BHCS, 1/4-28 x 1/4

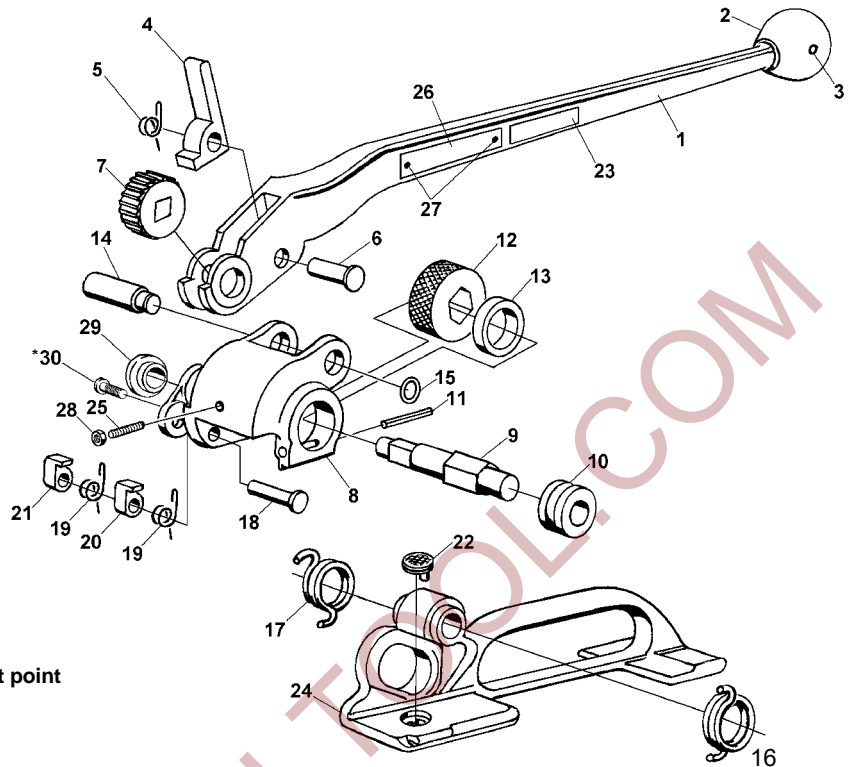

! When ordering parts, please show tool model, part number, and description.
! All recommended spare parts are underlined and should be stocked.

* Apply one drop of Loctite #271 (Red) or equivalent, available as Signode Part No. 422796.

NOTE: Keys numbers 8, 29 and 30 can be ordered together as Gear Housing Kit, Signode part No. 424438

WARNING All parts must be periodically inspected and replaced if worn or broken. Failure to do this can affect a product's operation and can result in personal injury.

FEEDWHEEL CLEARANCE ADJUSTMENT

1. The feedwheel (Key 12) clearance to the clutch plug (Key 22) should be set to .001"-.010" (0.02-0.25mm).
2. Loosen the locking nut (Key 28) which secures the adjustment screw (Key 25).
3. Adjust the clearance by turning the Socket Head Set Screw (Key 25) as required.
4. Tighten the locking nut (Key 28) to maintain the adjustment.

Occasional the clearance should be checked and reset if necessary. Failure to properly inspect and re-adjust the feedwheel clearance could result in damage to the feedwheel and/or the clutch plug.

For additional information and details on replacing the feedwheel and the clutch plug, contact your Signode Sales Representative.