

OPERATION, PARTS AND SAFETY MANUAL

SIGNODE®

WP-2
AIR POWERED TENSIONER

IMPORTANT!
DO NOT DESTROY

**It is the customer's responsibility to
have all operators and servicemen
read and understand this manual.**

Contact your local Signode representative
for additional copies of this manual.

READ ALL INSTRUCTIONS BEFORE OPERATING THIS SIGNODE PRODUCT

SIGNODE • 3620 WEST LAKE AVENUE • GLENVIEW, ILLINOIS 60025 U.S.A.

Distributed By:

Allstrap

1719 Kenny Rd
Columbus, OH, 43212

⚠ WARNING

READ THESE INSTRUCTIONS CAREFULLY.

FAILURE TO FOLLOW THESE INSTRUCTIONS CAN RESULT IN SEVERE PERSONAL INJURY.

GENERAL SAFETY CONSIDERATIONS

1. STRAP BREAKAGE HAZARD.

Improper operation of the tool or sharp corners on the load can result in strap breakage during tensioning, which could result in the following:

- ! A sudden loss of balance causing you to fall.
- ! Both tool and strap flying violently towards your face.

Failure to place the strap properly around the load or an unstable or shifted load could result in a sudden loss of strap tension during tensioning. This could result in a sudden loss of balance causing you to fall.

Read the tool's operating instructions. If the load corners are sharp use edge protectors. Place the strap correctly around a properly positioned load.

- ! Positioning yourself in-line with the strap, during tensioning and sealing, can result in severe personal injury from flying strap or tool. When tensioning or sealing, position yourself to one side of the strap and keep all bystanders away.
- ! Using strap not recommended for this tensioner can result in strap breakage during tensioning. Use the correct Signode products for your application.

2. TRAINING.

This tool must not be used by persons not properly trained in its use. Be certain that you receive proper training from your employer. If you have any questions contact your Signode Representative.

3. EYE INJURY HAZARD.

Failure to wear safety glasses with side shields can result in severe eye injury or blindness. Always wear safety glasses with side shields which conform to ANSI Standard Z87.1 or EN 166.



4. FALL HAZARD.

Maintaining improper footing and/or balance when operating the tool can cause you to fall. Do not use the tool when you are in an awkward position.

5. CUT HAZARD.

Handling strap or sharp parts could result in cut hands or fingers. Wear protective gloves.



Distributed By:

Allstrap

1719 Kenny Rd
Columbus, OH, 43212

⚠ WARNING

6. TOOL CARE, MAINTENANCE & PARTS REPLACEMENT

- ! Take good care of the tool. Inspect and clean it daily, lubricate it weekly and adjust when necessary. Replace any worn or broken parts.
- ! ALWAYS disconnect the pneumatic connection to the tool when performing part removal and/or replacement procedures. NEVER connect a pneumatic source to a disassembled tool unless otherwise specified.

7. WORK AREA.

Keep work areas uncluttered and well lighted.

Several combinations of strap, seals and tools can be used with this tensioner. Use the correct Signode products for your application. If you need help contact your Signode Representative.

SAFETY PROCEDURES FOR TOOL OPERATION

Before using this tool, read its Operation and Safety instructions.

- ! Do not exceed the operating air pressures stated elsewhere in the manual.
- ! Use a Signode approved filter-regulator-lubricator unit.
- ! Never operate a pneumatic tool with a bottled air or gas source.
- ! For tension adjustments, follow instructions in this manual. For all other adjustments, repairs or cleaning of the tool, disconnect air supply.
- ! Properly crimp or notch the seal(s).
- ! Tuck strap end back into the dispenser when not in use.

CUTTING TENSIONED STRAP

Use only cutters designed for cutting strap; never use claw hammers, crowbars, chisels, axes or similar tools. Such tools will cause the strap to fly apart with hazardous force. Before using any Signode product, read its Operation and Safety Manual.

Distributed By:

Allstrap

1719 Kenny Rd
Columbus, OH, 43212

TABLE OF CONTENTS

General Safety Instructions	2
Specifications	4
Pneumatic Information	5
Tool Installation	7
Tool Operation	8
Parts List & Exploded View	10
Repair Instructions	14
Maintenance	15

WARNING

Maximum operating pressure
is 90 psig (6.2 bar).

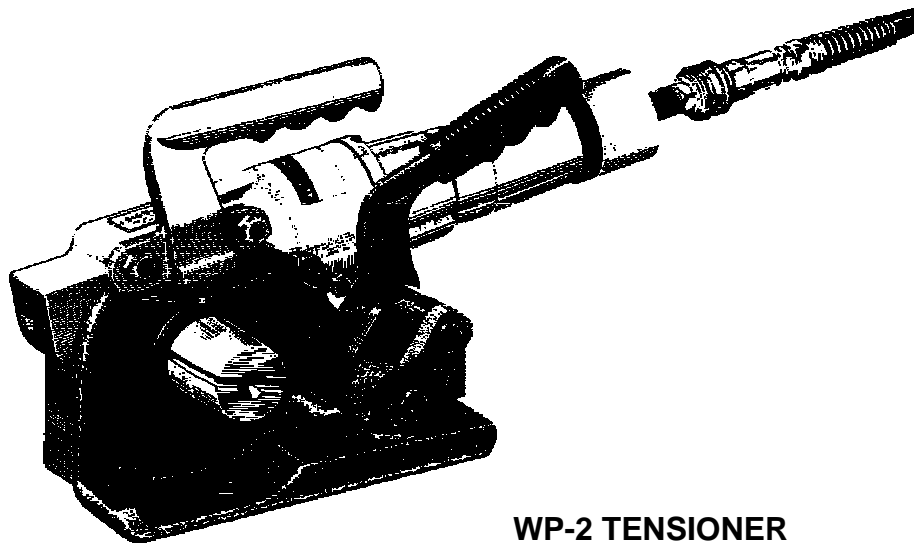

WP-2 TENSIONER
Part Number 023070

SPECIFICATIONS

MODEL	STRAP		
	TYPE	WIDTH	THICKNESS
WP-2	MAGNUS	2"	.044" to .050" (1.11-1.27mm)

Distributed By:

Allstrap

1719 Kenny Rd
Columbus, OH, 43212

PNEUMATIC INFORMATION

AIR SUPPLY INSTALLATION

If compressor has a good dryer unit, use black pickled pipe. When a dryer unit is not installed, use galvanized or copper pipe. To perform reliably, a pneumatic tool requires a continuous source of clean, water-free air at adequate pressure.

! WARNING

Never operate this tool using a bottled air or gas source.
Bottled air/gas sources do not provide consistent operating pressure

A filter-regulator-lubricator (FRL) unit must be installed as close to the air tool as possible, preferably within 10 feet. It should be placed in a convenient location where it can easily be drained, adjusted, and filled with oil. The air hose must have at least a 3/8" I.D. A quick disconnect socket fitting is installed on the stress spring end of the hose for convenient hookup to the air tool.

Filter-Regulator-Lubricator Unit
(Signode Part No. 008559 or 173111)

FRL Mounting Bracket
(Signode Part No. 071982)

Air Hose, 3/8" ID, 1/4" Fittings
(Signode Part No. 008558)

Reducer Bushing, 3/8" to 1/4"
(Signode Part No. 008478)

Quick Disconnect, 1/4" Fitting
(Signode Part No. 020706)

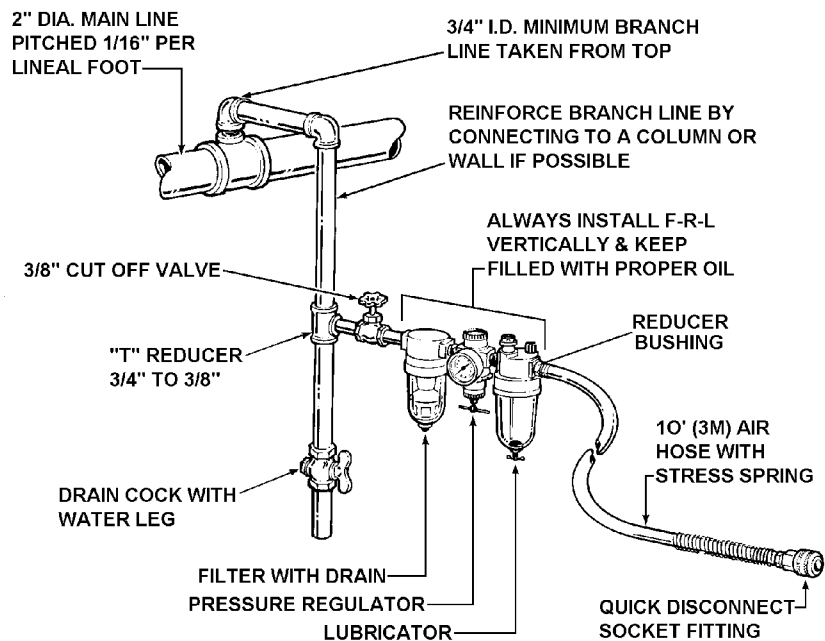

Filter and lubricator bowls are made of polycarbonate material. Do not install where bowls may be exposed to materials incompatible with polycarbonate. Certain oils, solvents, and chemicals or their fumes can weaken these bowls and possibly cause them to burst. Clean only with warm water. A cut-off valve placed ahead of the filter will be useful when cleaning the filter or replenishing the lubricator.

Distributed By:

Allstrap

1719 Kenny Rd
Columbus, OH, 43212

PNEUMATIC INFORMATION, Continued

MOISTURE

Moisture is always present in air lines due to condensation within the lines as the air cools. Steps must be taken to remove this moisture and to keep it from the air tool. This is because water tends to wash away lubricants and cause corrosion, sticking and failure of internal parts.

The main line should be pitched so the far end terminates in a water leg. Branch lines are taken from the top of the main, never off the bottom. Every branch should have a water leg at its lowest point, with a drain cock which is drained daily.

If these precautions are taken and water is still present, an after cooler and a moisture separator are required between the compressor and the air receiver tank. A large air line separator can be installed in the air tool line, but precautions must be taken to insure that it will be drained daily, before the air tool is operated.

Water in air lines is a constant threat to the proper operation of air tools. Even near freezing operating conditions, a good refrigerant type dryer is essential. A good dryer will remove 95% or more of water right at the compressor. The remaining moisture is removed at the water leg in the piping system or in the filter.

NOTE: Additional information is available in the Signode publication, "Air Supply Manual" (Part No. 186038). If you have any questions, contact your local Signode Representative.

LUBRICATION

The air tool must be properly lubricated. This is achieved by keeping the air line lubricator filled with oil and correctly adjusted. Without proper lubrication, the tool will become sticky and will be difficult to release from the strap.

Install the lubricator as close to the air tool as possible. The arrow on the lubricator's top surface must point in the direction of air flow.

For proper operation, oil must drop through the lubricator sight glass at a rate of 4 to 10 drops per minute. This rate is checked while the air tool is running free. Only 20% of this oil is actually delivered to the tool. The remaining oil drops back into the oil reservoir. The unit is factory set and should require no adjustment. If an adjustment is required, the adjusting screw on top of the lubricator may be turned as marked to reduce or increase the flow of oil.

The correct grade of oil must be used in the lubricator; too heavy an oil will not provide sufficient lubrication and will cause sticking and sluggish operation of the air tool.

Recommended oils are any good grade of rust and oxidation inhibiting oil with a viscosity of 80-120 S.U.S. at 100 degrees Fahrenheit. (0.15 to 0.25 cm² /sec. at 38 degrees Celsius), such as:

Non Fluid Oil Co., grade #LS-1236
Signode oil - Part No. 008556

If necessary, use SAE #5 or SAE #10 non-detergent, cut 1 to 1 with kerosene.

Distributed By:

Allstrap

1719 Kenny Rd
Columbus, OH, 43212

NOTE: Some oils contain anti-wear additives which may disable the tool. Be certain to use recommended oil.

Several drops of lubricator oil added to the inlet of the air line each day will help insure good operation. A noticeable reduction of performance can usually be corrected by squirting a few drops of oil into the air line.

COLD WEATHER OPERATION

If a tool does not operate satisfactorily in freezing temperatures, certain steps can correct the problem. The following steps can be taken to improve cold weather operation of the tool:

- a. An air line dryer adjacent to the compressor.
- b. Use lubricant recommended by Signode. Signode has tested the use of anti-freezes, none work well in air tools; the tool will gum up when anti-freezes are introduced and will not function properly. The best lubricant for freezing weather is the 1 to 1 oil and kerosene combination.
- c. If possible, run the air supply line to a indoor located Filter-Regulator-Lubricator or relocate the F-L-R to a warmer operating area.

AIR PRESSURE VS. APPROXIMATE STRAP TENSION

Air Line Pressure (psig)	Strap Tension (lbs.)
50 psig (345 kPa)	4,000 lb. (17800 N)
60 psig (415 kPa)	5,000 lb. (22200 N)
70 psig (485 kPa)	6,000 lb. (26700 N)
80 psig (550 kPa)	7,000 lb. (31100 N)
90 psig (620 kPa)	8,000 lb. (35600 N)

Recommended strap sizes (MAGNUS)	Recommended air pressure (psig)
2" x .044	50 to 90 psig
2" x .050	50 to 90 psig



WARNING

Strap breakage hazard. Strap can break during tensioning if inlet air pressure to the tool exceeds 90 psig. Strap breakage can result in severe personal injury. Maximum operating pressure is 90 psig.

TOOL INSTALLATION

To operate effectively, your tool must be installed properly. This installation includes proper suspension of the tool over the package to be strapped, correct placement of a strapping dispenser to provide a continuous easy supply of strap for the application, and a satisfactory air supply with air line pressures being maintained within the specified range.

TOOL OPERATION

⚠ WARNING

Wear safety glasses which conform to ANSI standard Z87.1 or EN 166. Stand to one side of the strap while tensioning.

Make sure all bystanders are clear before proceeding.

1. Raise the gripper wheel by pressing down on the pawl handle. Insert the bottom strap and release the pawl handle. Allow one foot of strap to extend beyond the front of the tool.

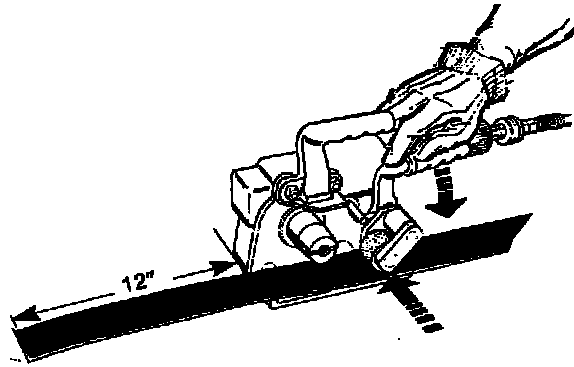

2. Thread seals properly on to upper strap.

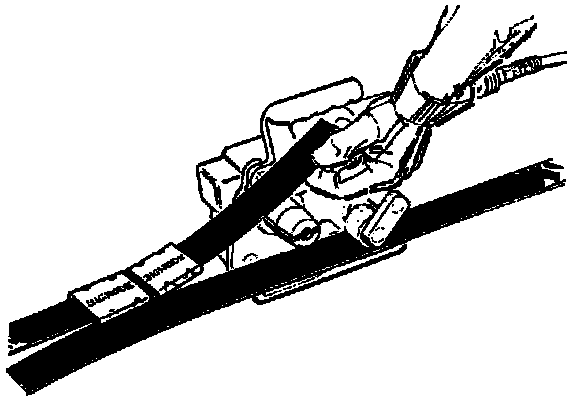

3. Thread strap in to the windlass and under the strap pin. Strap should extend 4" - 8" beyond the windlass.

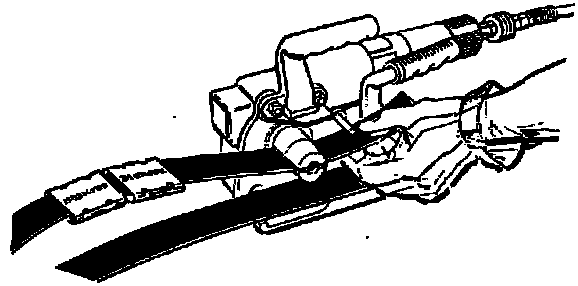

NOTE: Make sure straps are fully seated against the base.

4. Pull out slack, turn valve clockwise to rotate windlass about 1/2 turn to secure strap in the windlass.

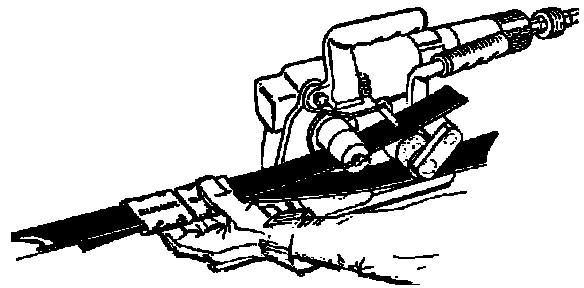

5. Thread seals properly on to bottom strap.

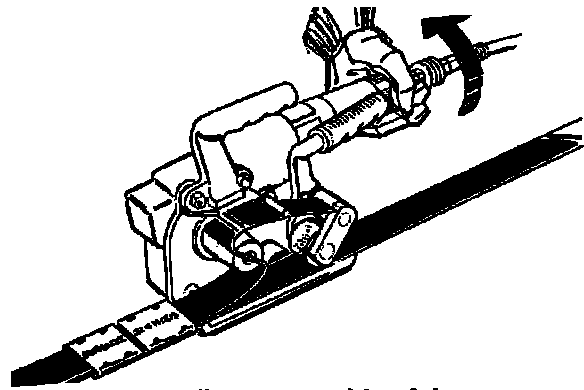

Distributed By:

Allstrap

1719 Kenny Rd
Columbus, OH, 43212

6. While standing to one side of the strap line, rotate the valve collar clockwise to tension strap allowing motor to stall out at desired tension.

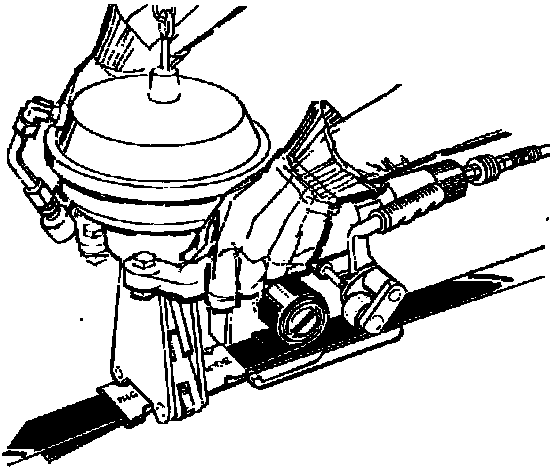

If for some reason the gripper will not energize, do not try to energize using the pawl handle, as this will result in disengagement of the ratchet wheel. Apply light machine oil to the pivot pin (5), until the lever moves freely.

7. At the end of the tensioning cycle, use sealing tool to notch or crimp seals.

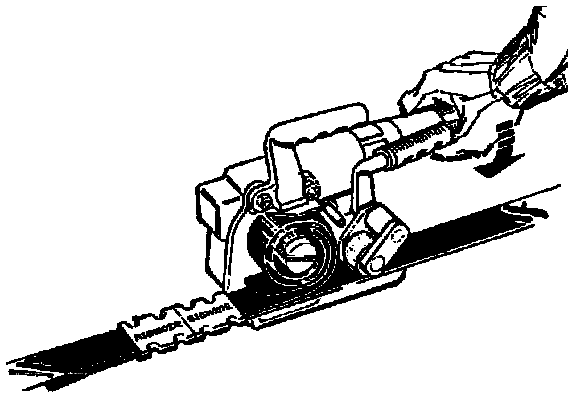

8. After sealing the strap, rotate the valve collar counterclockwise to unwind the windlass. Note tab end of strap in windlass. When this becomes loose, the tool will be easily removed. The valve collar is spring loaded to the reverse direction so that when released, the valve will return to neutral.

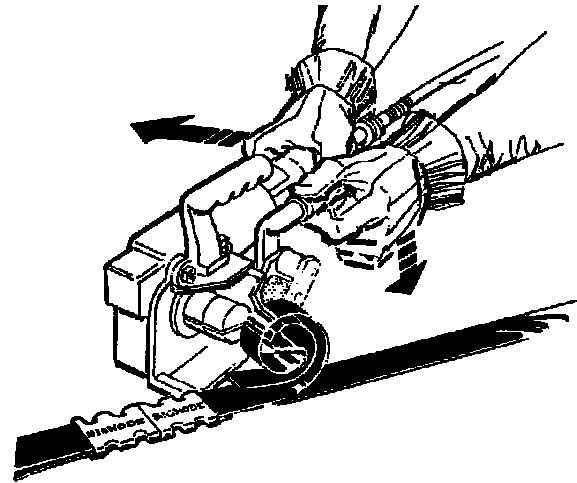

Lift the pawl handle thereby disengaging the ratchet wheel. Then press down on the pawl handle and rotate the tool off the strap in a counterclockwise direction.

PARTS LIST, TOOL

KEY	QTY	PART #	DESCRIPTION	KEY	QTY	PART #	DESCRIPTION
1	1	160479	Bearing shim	13	1	008827	Idler plate
2	1	002481	Name plate	14	1	008829	Ring gear
3	3	005211	Flexlock nut 3/16-18	15	1	008148	Roll pin, 1/8 x 7/16
4	2	005214	Roll pin 1/4 dia. x 3/4	16	1	008854	Ball bearing 7304W
5	2	004939	Drive screw	17	1	023053	Base
6	1	008154	FHSCS, 3/16-18 x 1	18	1	023054	Gear housing
7	3	008531	Stud	19	1	023055A	Motor
8	6	008731	SHCS, 10-24 x 3/4	20	1	023056	Spiriod gear
9	1	008774	Key, Woodruff #3	21	1	023057	Spiriod worm
10	3	008815A	Idler gear assembly	22	1	023058	Pawl handel
11	1	008825	Spacer	23	1	023059	Windlass
12	1	008826	Key	24	1	023063	Gripper

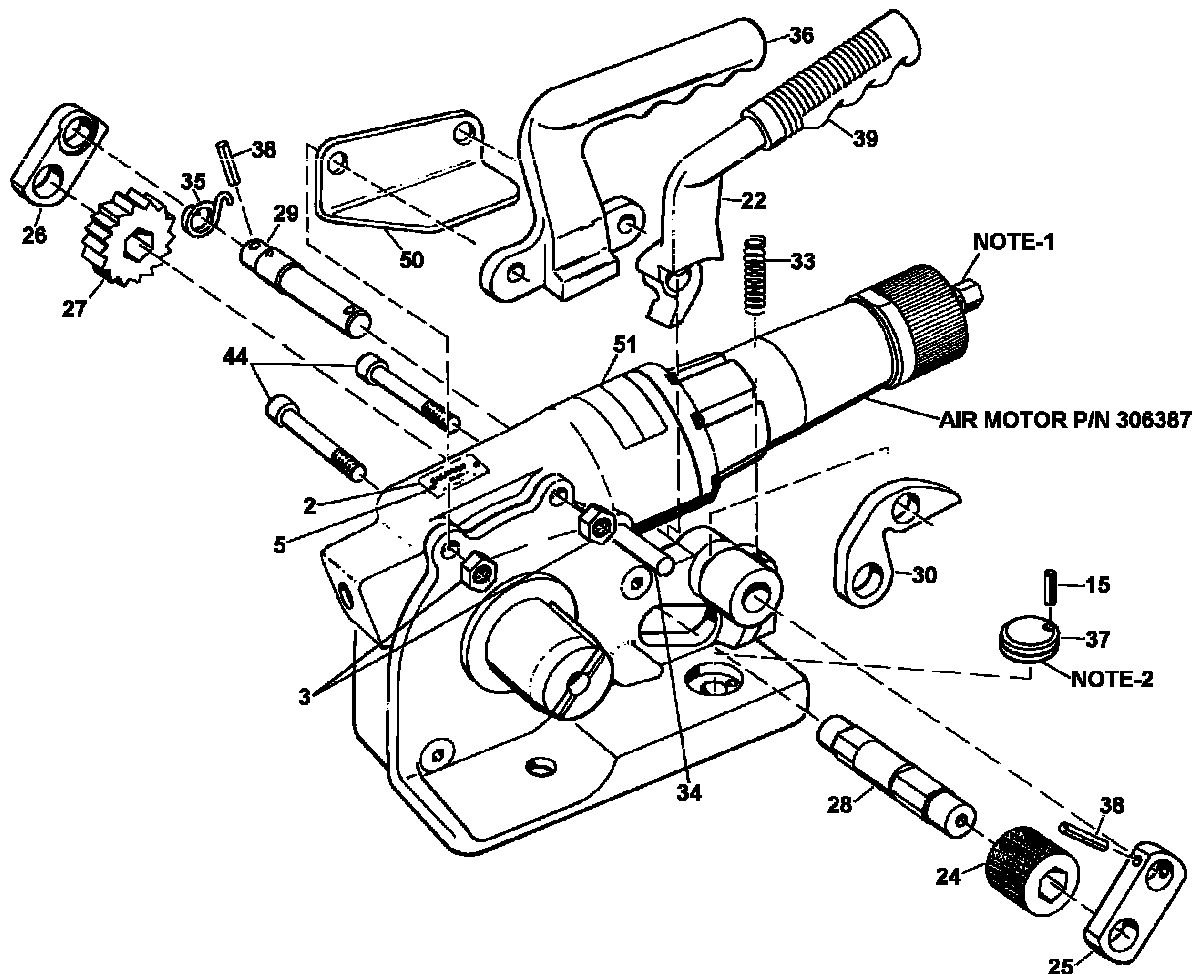

NOTE 1. Use large quick disconnect fittings: Socket P/N 0200706, Plug P/N 020704
 NOTE 2. Assemble wear pad with "B" side down.

- ! When ordering parts please show tool model, part number and name.
- ! Standard hardware parts may be obtained from your local hardware supplier.
- ! Recommended spare parts are underlined and should be stocked.

KEY	QTY	PART #	DESCRIPTION
25	1	023064	Front link
26	1	023065	Rear link
27	1	023066	Ratchet gear
28	1	023067	Gripper shaft
29	1	023068	Support pin
30	1	023069	Center link
31	1	023071	Spacer
32	1	023072	Key, Woodruff #21
33	1	023073	Gripper spring
34	1	023074	Strap pin
35	1	023075	Pawl spring
36	1	023076	Tool handle

KEY	QTY	PART #	DESCRIPTION
37	1	023077	Wear pad
38	2	023080	Roll pin 3/16 x 7/8
39	1	023668	Plastic grip
40	1	008645	Bearing,Fafnir 205KDD
41	1	023742	Bearing,Fafnir 210PP
42	1	023743	Bearing,Torr. M-871
43	1	023744	Oil Seal
44	2	023745	SHCS,5/16-18x2-3/4
45	1	023746	FHSCS,5/16-18x2-1/4
50	1	023272	Handel protector
51	1	003132	Danger Sign

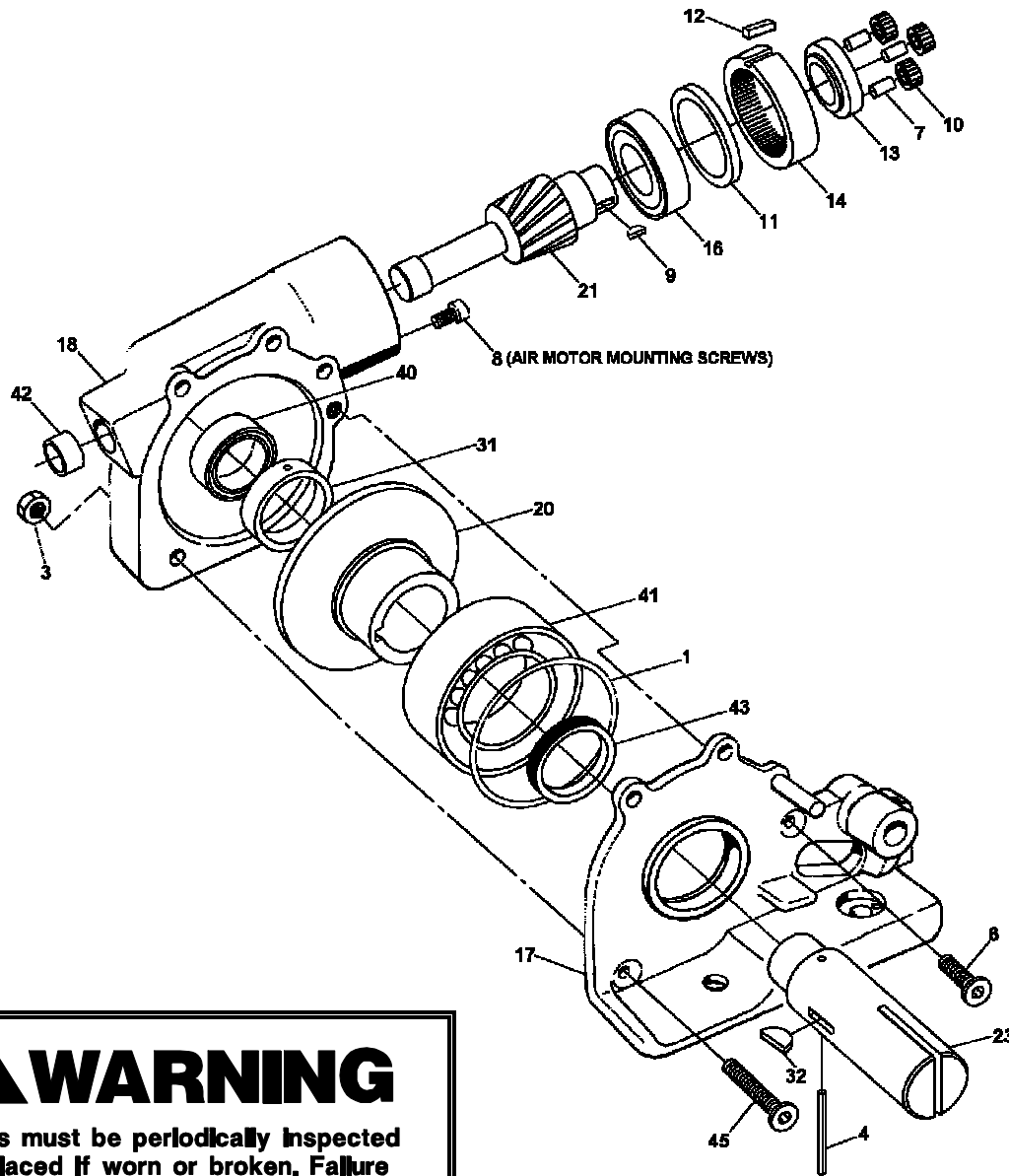

⚠ WARNING
All parts must be periodically inspected and replaced if worn or broken. Failure to do this can affect a product's operation and can result in personal injury.

PARTS LIST, AIR MOTOR 306387

<u>KEY</u>	<u>QTY.</u>	<u>PART NO.</u>	<u>DESCRIPTION</u>
1	1	422221	Ball bearing
2	1	422222	End plate
3	1	422223	Pin
4	1	422224	Cylinder
5	1	422701	Rotor
6	1	422702	Pin
7	1	422227	Ball bearing
8	1	422703	End plate
9	5	422229	Vane
10	1	422704	Motor casing
11	1	422232	Flow washer
12	1	422233	Axle
13	1	422234	Valve
14	1	422235	Spring
15	1	422236	O-ring
16	1	422237	O-ring
17	1	422238	Adapter
18	1	422239	Circlip
19	1	422240	Sleeve
20	1	422241	Bearing needle
21	1	422242	Throttle ring
22	1	422243	Bearing needle
23	1	422244	Pin
24	1	422705	Silencer
25	1	422246	Circlip
26	1	422247	Silencer
27	1	422248	Cover
28	1	422249	Silencer
29	1	422250	O-ring
30	1	422251	Cup spring
31	1	422752	Washer
32	1	422753	Lubricating nipple
33	1	422754	Circlip
34	2	422756	Ball bearing
35	1	422757	Gear rim
36	1	422706	Flange
37	2	422707	Circlip
38	1	422708	Planet shaft
39	2	422266	Axle pin
40	2	422767	Needle bearing
41	2	422709	Gear wheel

- ! When ordering parts please show tool model, part number and name.
- ! Standard hardware parts may be obtained from your local hardware supplier.

TROUBLESHOOTING TIP - If the air motor does not run or runs sluggishly:

1. Observe the air pressure gauge and adjust the regulator if necessary.
2. Inspect the filter screen in the air motor inlet. Clean the filter if necessary.
3. Inject one (1) teaspoon of lubricator oil into the air motor inlet. Let the air motor run free. If motor speed increases, check lubricator to see that it is filled and properly adjusted.

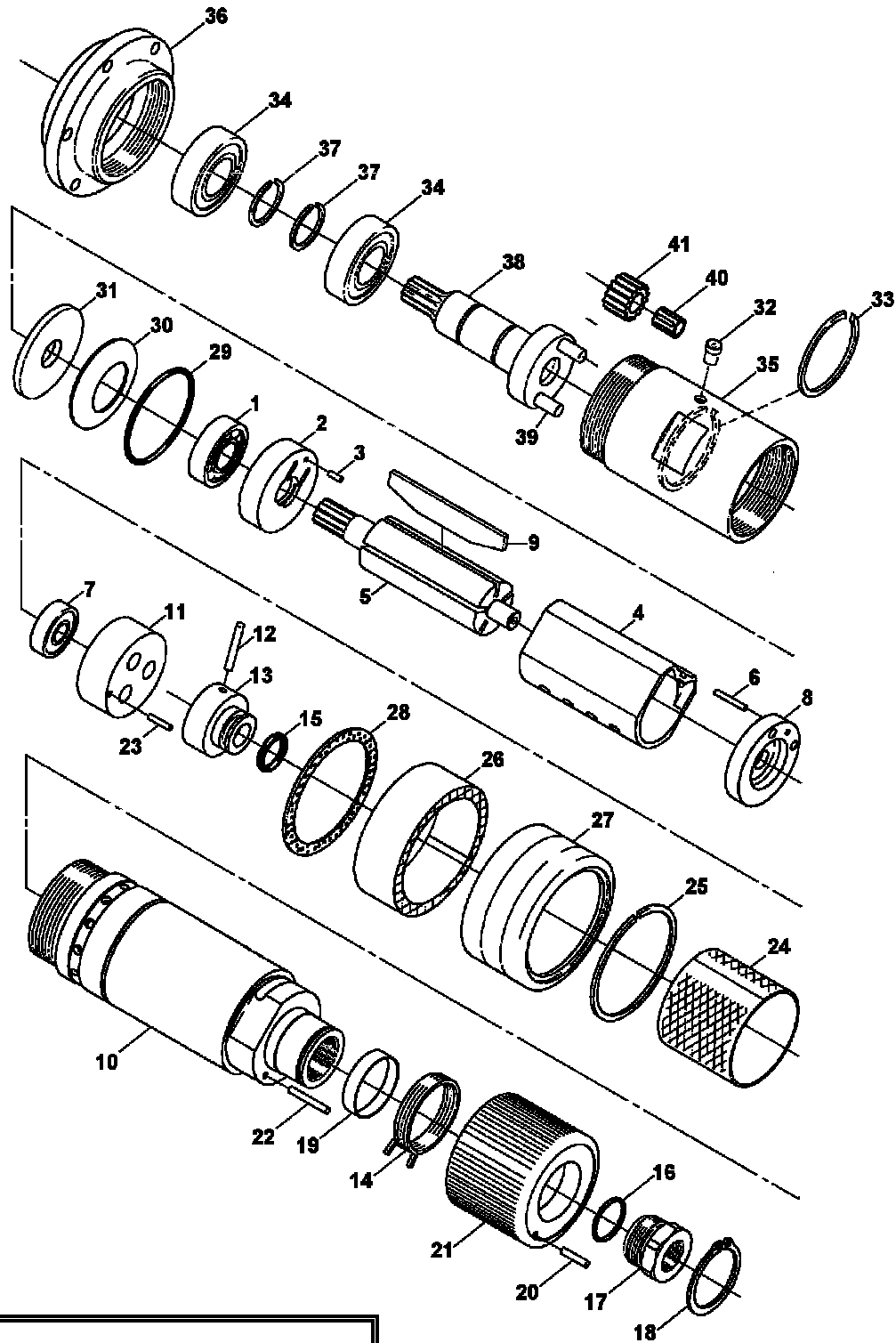

⚠ WARNING

All parts must be periodically inspected and replaced if worn or broken. Failure to do this can affect a product's operation and can result in personal injury.

REPAIR INSTRUCTIONS

Refer to pages 10 & 11 of this manual for additional part information and location.

GRIPPER AND WEAR PAD DISASSEMBLY

Remove the following parts:

- ! Front roll pin (38)
- ! Front link (25)
- ! Gripper (24)
- ! Roll pin (15)
- ! Wear pad assembly (37)

Clean, inspect and replace worn and/or broken parts. Clean gripper with wire brush.

NOTE: Gripper can be re-used by rotating it to a new position on the hexagonal gripper shaft.

GRIPPER AND WEAR PAD REASSEMBLY

Clean, inspect and replace worn and/or broken parts before reassembly. Lubricate all moving parts with Mo-Lith #2 grease, or equivalent, before reassembly. Install the following parts as described:

- ! Wear pad assembly (37)
- ! Roll pin (15)
- ! Gripper (24) - Rotate gripper so that unworn teeth contact the strap.
- ! Front link (25) - Grasp the support pin (29) with pliers at rear link (26) and rotate to align hole.
- ! Front roll pin (38) - Drive in roll pin. Check that pawl handle is spring loaded in both directions.

TOOL MAINTENANCE

GENERAL - The most common reason for poor tool performance and incorrectly formed straps joints is improper tool maintenance. The easiest way to determine if a tool is performing correctly is by inspecting the strap joint. Having a tool maintenance program is a simple task which consists of three parts. First, a quick daily inspection of the tool for any worn or broken parts. Secondly, keep each tool on a schedule of service intervals for cleaning and lubrication. Third, when problems do occur, use the troubleshooting guide to properly determine and fix problems before they lead to more serious tool conditions. Each of these three tasks have been outlined for this particular tool, read and understand all information for improving the life and performance of the tool.

SPECIFIC:

At the beginning of the day:

1. Drain filter and moisture traps in the air line.
2. Check lubricator oil level and refill if necessary.
3. Observe air pressure gauge to determine that the regulator is adjusted to the correct pressure.
4. Use a wire brush to clean the gripper.

At the end of the day:

1. Disconnect the air hose from the tool.
2. Rotate the twist-valve clockwise and squirt one (1) teaspoon of lubricating oil into the air motor.
3. Return the twist-valve to neutral and reconnect the air hose.
4. Rotate the twist-valve clockwise and allow the air motor to run free for one minute. Wipe excess oil from the exhaust with a cloth.

TOOL INSPECTION - Visually inspect the exterior of the tool on a daily basis. Decreased tool life can be prevented by early detection of broken parts. Replace all broken parts with new parts. Review the Parts Removal, Replacement & Adjustments portion of this manual for information and details.

SERVICE INTERVALS - Tool component wear is affected by the environment and strap tension that the tool is subjected to. In the worst case, heavy gauge wide strapping. All critical moving components of the tool should be inspected at particular intervals, some more often than others. Broken parts can lead to additional component wear and produce lower strap tension.

DANGER

If there is any question that joint formation is not as shown or is suspect, it is important that you contact your tool representative immediately.

TOOL LUBRICATION - Signode tools use a variety of greases and oils, all of which can be ordered through Signode. When ordering indicate tool model, part number and name. The gear housing of this tool should be packed 1/3 full with non-fluid oil #K55. Pack any open bearings before assembly.

THREAD SEALANTS - Signode tools are assembled using a variety of thread sealants, all of which can be ordered through Signode using the appropriate description shown below.

- ! Loctite #222
- ! Loctite #242
- ! Loctite #609

**SIGNODE
NEW TOOL WARRANTY**

Signode Engineered Products Warrants that a new Signode strapping tool will operate per functional specifications for a period of sixty (60) days after the date of shipment to the owner's place of business. Normal wearing parts, as outlined in the Operation, Parts & Safety manual, are covered by a thirty (30) day warranty unless, in Signode's judgement, these parts have been subjected to abnormal or extreme usage. Signode's sole liability hereunder will be to repair or replace, without charge, F.O.B. Signode's Glenview, Illinois plant, any tool which proves to not operate per functional specifications within the stated period. Signode reserves the right to replace any tool which proves not to operate per functional specifications with a new or like-new tool of the same model if in Signode's judgement such replacement is appropriate. Any new replacement tool provided to an owner will carry a full sixty (60) day warranty. Any warranty repaired tool or like-new replacement tool will carry a warranty for the balance of the time remaining on the initial sixty (60) day warranty. This warranty will be extended to compensate for the time the tool is in Signode's possession for warranty repairs.

This warranty is void as to any tool which has been: (I) subjected to mis-use, misapplication, accident, damage, or repaired with other than genuine Signode replacement parts, (II) improperly maintained, or adjusted, or damaged in transit or handling; (III) used with improperly filtered, unlubricated air or improper strapping material, (IV) in Signode's opinion, altered or repaired in a way that affects or detracts from the performance of the tool.

SIGNODE MAKES NO WARRANTY, EXPRESSED OR IMPLIED, RELATING TO MERCHANTABILITY, FITNESS OR OTHERWISE EXCEPT AS STATED ABOVE AND SIGNODE'S LIABILITY AS ASSUMED ABOVE IS IN LIEU OF ALL OTHERS ARISING OUT OF OR IN CONNECTION WITH THE USE AND PERFORMANCE OF THE TOOL. IT IS EXPRESSLY UNDERSTOOD THAT SIGNODE SHALL IN NO EVENT BE LIABLE FOR ANY INDIRECT OR CONSEQUENTIAL DAMAGES INCLUDING, BUT NOT LIMITED TO, DAMAGES WHICH MAY ARISE FROM LOSS OF ANTICIPATED PROFITS OR PRODUCTION, SPOILAGE OF MATERIALS, INCREASED COSTS OF OPERATION OR OTHERWISE.

Considerable effort has been made to ensure that this product conforms to our high quality standards. However, should you experience any difficulties, please contact your Sales Representative providing samples and the manufacturing code specified on the tool.

Thank you for your help.

SIGNODE ENGINEERED PRODUCTS
Hand Tool Division
3620 W. Lake Avenue, Glenview, Illinois 60025

PART #	DESCRIPTION	AREA OF USE
LUBRICANTS		
177029	BROWN K-55 GREASE	CLUTCH DRIVES, INTERNAL GEARS, GEAR SETS
422792	WHITE LUBRIPLATE GR-132 GREASE	PNEUMATIC PARTS, AIR CYLINDERS, AIR VALVES, O-RINGS
422793	BLACK LUBRIPLATE 3000W GREASE	MOVING INTERNAL PARTS, JAWS, LINKS
432322	EP ACCROLUBE GREASE	HIGH FRICTION CONTACT PARTS
008556	LS-1236 AIR LINE OIL	AIR MOTORS, AIR VALVES
ADHESIVES		
422794	LOCTITE #222, PURPLE	LOW STRENGTH, SCREWS 1/4" (6MM) OR SMALLER SIZES
422795	LOCTITE #242, BLUE	MEDIUM STRENGTH, SCREWS 5/16" (8MM) OR LARGER SIZES
422796	LOCTITE #271, RED	HIGH STRENGTH, SEMI-PERMANENT SCREW APPLICATION
422797	LOCTITE #609, GREEN	PERMANENT, CURVED SURFACE PART CONTACT
274111	LOCTITE #380, BLACK MAX	PERMANENT, FLAT SURFACE PART CONTACT
CLEANING BRUSHES		
023963	SMALL BRUSH	FEEDWHEEL & GRIPPER TEETH
269589	LARGE BRUSH	FEEDWHEEL & GRIPPER TEETH