

MIP - 370 POLY STRAP TENSIONER

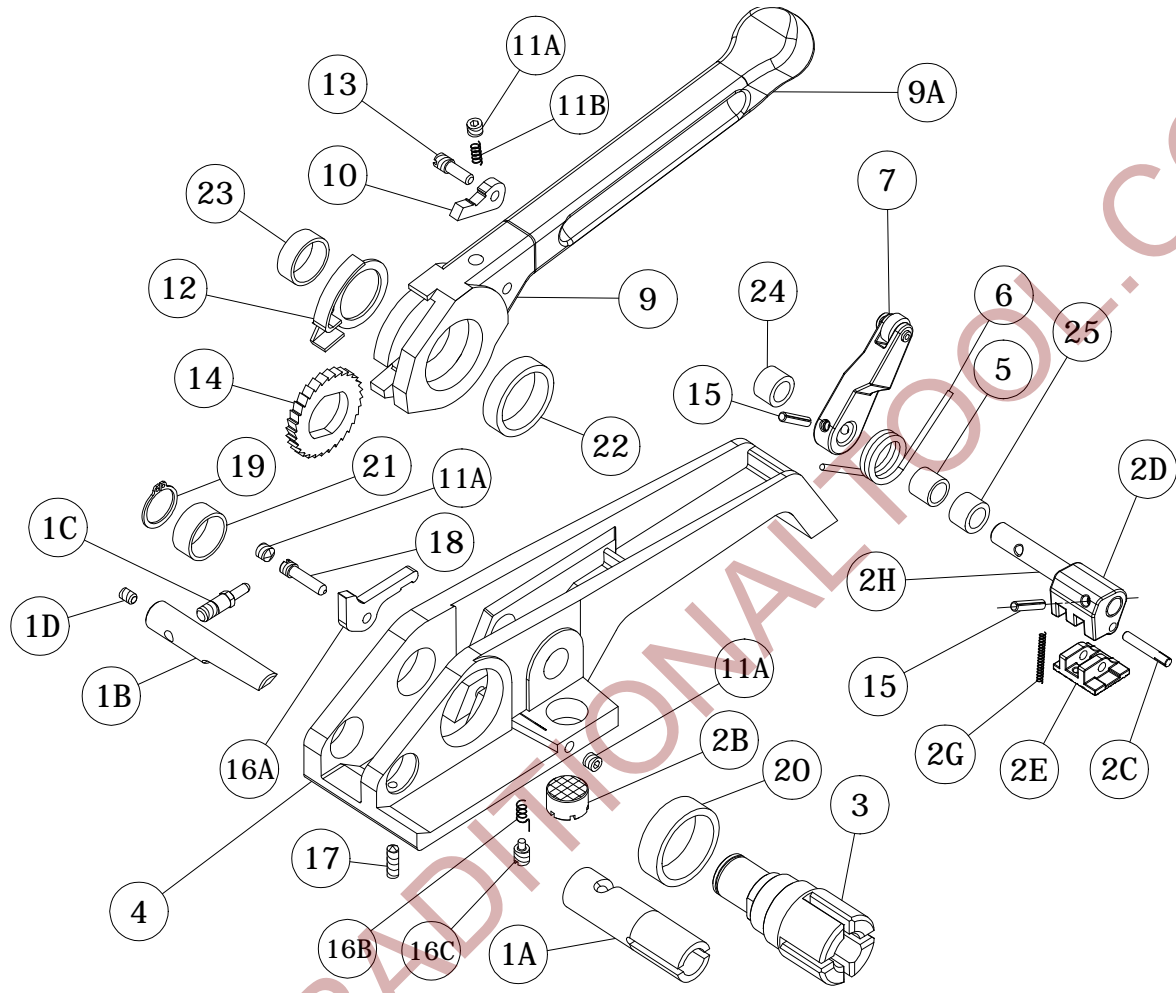

KEY#	DESCRIPTION	QTY	PART#
Note: 1A & 1B sold only as assembled unit.			
• 1A	Cutter Housing	1	M370-1A
• 1B	Cutter Blade	1	M370-1B
• 1C	Cutter Actuating Pin	1	M370-1C
• 1D	Set Screw	1	M370-1D
• 2B	Base Plug	1	M370-2B
• 2C	Gripper Foot Pin	1	M370-2C
• 2D	Gripper Foot Housing	1	M370-2D
• 2E	Gripper Foot	1	M370-2E
• 2G	Gripper Spring	1	M370-2G
• 2H	Gripper Pin	1	M370-2H
• 3	Windlass	1	M370-3
• 4	Base – Includes Finishing	1	M370-4
• 5	Spacer	1	M370-5
• 6	Release Lever Spring	1	M370-6
• 7	Release Lever (Includes Roller & Machined Rivet)	1	M370-7
• 9	Handle	1	M370-9
• 9A	Handle Grip – Blue	1	M370-9A

KEY#	DESCRIPTION	QTY	PART#
• 10	Handle Pawl	1	M370-10
• 11A	Set Screw	3	M370-11A
• 11B	Spring	1	M370-11B
• 12	Cutter Actuator	1	M370-12
• 13	Handle Set Screw	1	M370-13
• 14	Ratchet Gear	1	M370-14
• 15	Roll Pin	2	M370-15
• 16A	Body Pawl	1	M370-16A
• 16B	Bottom Pawl Spring	1	M370-16B
• 16C	Set Screw	1	M370-16C
• 17	Set Screw Cutter Housing	1	M370-17
• 18	Body Pawl Retaining Screw	1	M370-18
• 19	Circlip – Windlass	1	M370-19
• 20	Large Body Bushing	1	M370-20
• 21	Small Body Bushing	1	M370-21
• 22	Large Brass Handle Bushing	1	M370-22
• 23	Small Brass Handle Bushing	1	M370-23
• 24/25	Bronze Bushing Gripper Foot	2	M370-24/25

Reference part number when ordering.

- Key wear part
- Read all operating & safety instructions.

MIP-370 OPERATING INSTRUCTIONS

OPERATING INSTRUCTIONS:

1. Pull the strap completely around the package and under the other end of strapping. Be sure to keep the strap snug about the package and squarely in line.
2. Holding the strap in place with the left hand, take the tool in the right hand and squeeze the handle (Key #9) down to the base (Key #4). Slide the tool onto the strap such that the end of strap facing the front of the tool passes between the bottom gripper foot and base plug (Key #2E and #2B), under the cutter housing (Key #1A), and extends about four inches past the front of the tool. (See diagram) For best results, ensure that the strap is centered across the base plug (Key #2B). Release the handle to clamp down on the strap.
3. Thread the end of the strap facing the back of the tool through the cutter housing (Key #1A), and then through the slot in the windlass (Key #3). (See diagram)
4. Place a seal over both pieces of strapping directly in front of the tensioner.
5. Tighten the strap by moving the handle up and down.

WARNING: While tensioning, be sure NOT to bring the handle all the way back down to the base. Doing so causes the cutter to actuate and gripper foot assembly to rise, releasing the tensioned strap.

6. Crimp seal with an appropriate heavy-duty poly strap sealer, according to sealer manufacturer's instructions.
7. With the seal securely in place, press the handle down to the base to cut the strap and raise the gripper foot. With the handle down, slide the tool to the right and move away from the strapping.
8. Remove and discard remaining strap around windlass.

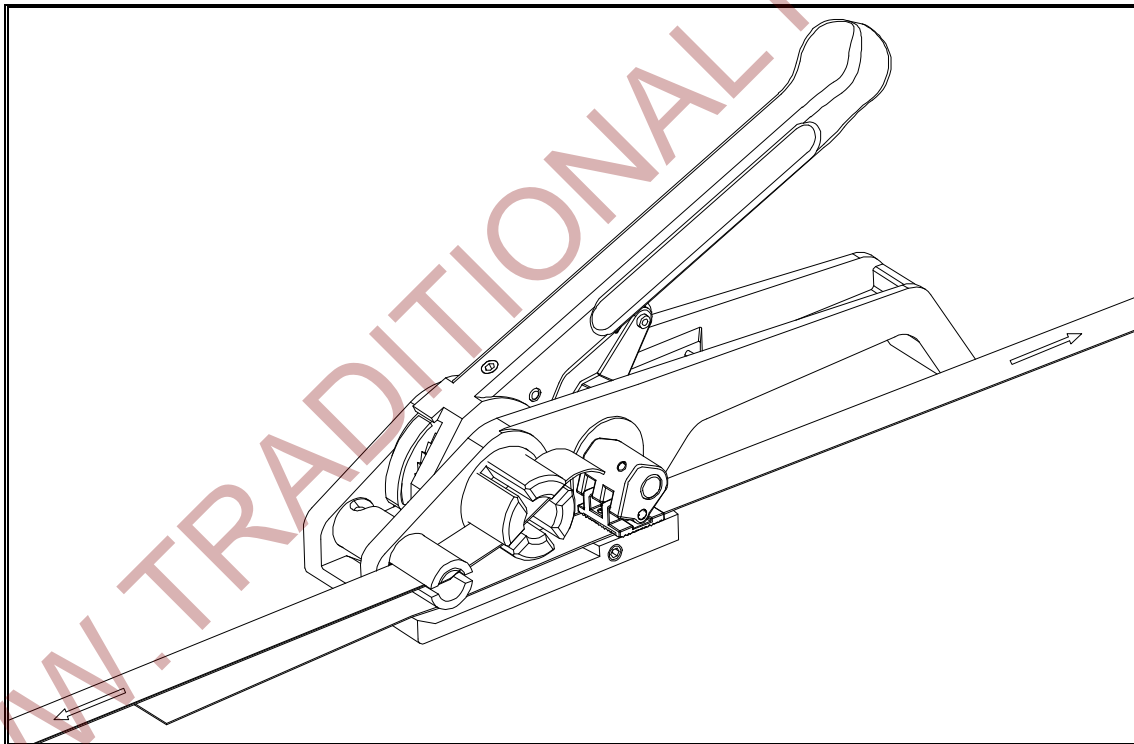

SAFETY WARNINGS:

- Before operating the tool, review the enclosed MIP, Inc. General Hand Tools and Strapping Safety booklet. Only trained personnel should operate MIP, Inc. hand tools.
- Only use equipment recommended for the strap. The MIP-370 is recommended only for $\frac{1}{2}$ through $\frac{3}{4}$ poly strapping.
- Keep fingers away from areas that can pinch or cut.
- Dangerous breakage may occur due to excessive tensioning, possibly resulting in severe injury or death. Tension strap in moderation.
- Review the instructions and safety material on a regular basis.
- **Warning:** Unsafe use may result in blindness, severe laceration, amputation, or death.