

DEUTSCH	3
ENGLISH	14
FRANÇAIS	25
ITALIANO	36

BETRIEBSANLEITUNG UND SICHERHEITSVORSCHRIFTEN
OPERATING AND SAFETY INSTRUCTIONS
MODE D'EMPLOI ET DE SÉCURITÉ
ISTRUZIONI PER L'USO E DI SICUREZZA

OR-T 100

Ab Serie-Nr. 1/51902
 From serie no 1/51902
 A partir du no de série 1/51902
 A partire dal no di serie 1/51902

Akku-Handgerät zum Umreifen mit Kunststoffband
 Battery-hand tool for plastic strapping
 Appareil sur accu pour le cerclage par bande plastique
 Apparecchio da batteria per reggiare con reggetta di plastica



Vor dem Gebrauch des Gerätes die Betriebsanleitung aufmerksam lesen.

Before using the tool, read the operating instructions carefully.

Avant l'utilisation de l'appareil, consultez soigneusement le mode d'emploi.

Prima d'utilizzare l'apparecchio, leggere attentamente le istruzioni per l'uso.



TTR **TRADITIONAL**
TOOL REPAIR, INC.
 WWW.TRADITIONALTOOL.COM

TABLE OF CONTENTS

	Page
1 Technical data	14
2 General information	15
2.1 Information on environmental protection	15
3 Safety instructions	16
3.1 Safety instructions for battery charger and battery	16
4 Description	17
4.1 Construction	17
4.2 Operating panel	17
4.3 Function	17
4.4 Battery charger indicators	18
5 Initial operation	19
5.1 Battery charger	19
5.2 First battery charge	19
5.3 Charging the battery	19
6 Operating instructions	20
6.1 Operating the tool	20
6.2 Checking the seal	21
6.3 Operating panel	22
6.3.1 Checking battery charge	22
6.3.2 Setting strap tension	22
6.3.3 Setting welding time	22
6.4 Setting strap width	23
7 Preventive and corrective maintenance	24
7.1 Cleaning/replacing tension wheel	24
7.2 Cleaning/replacing tooth plate	24
7.3 Replacing cutting knife	24
8 Recommended spare parts	47
8.1 Parts list	47
Exploded drawing	53

1

TECHNICAL DATA

Weight	3.5 kg (7.7 lbs) (incl. battery)
Dimensions	Length 375 mm (14.7") Width 130 mm (5.1") Height 140 mm (5.5")
Strap tension	0–700 N
Tension speed	330 mm/s (12.9"/s)
Sealing	Friction welded
Emission sound pressure levels, measurement type A (EN ISO 11202)	L_{pA} 82 dB (A)
Vibrations at handle (EN ISO 8662-1)	$a_{h,w}$ 2.2 ms ⁻²

BATTERY CHARGER / BATTERY

Voltage	Battery charger, 100/240 V (AL 60 DV 1419) Bosch 12 V / 2.4 Ah / NiCd
Charging time	60 minutes
Strappings with one battery charge	Up to 300 depending on strap, strap tension and package
Service life	Up to approx 2000 chargings

PLASTIC STRAP

Strap quality	Polypropylene (PP) Polyester (PET)
Strap width adjustable to	9–11 mm ($\frac{3}{8}$ ") (PP, PET) 12–13 mm ($\frac{1}{2}$ ") (PP)
Strap thickness	0.5–0.8 mm (.020"–.031")

DECLARATION OF AGREEMENT

We take sole responsibility for declaring that the tool OR-T 100, to which this declaration refers, is in full compliance with the current requirements of the guidelines laid down by the council on 22th June 1998 (98/37/ECC), "Machine Guidelines".

Furthermore, electrical installations are in compliance with the guideline laid down by the council on 19. February 1973 (73/23/EEC) "Low Voltage Guidelines" and from 3th May 1989 (89/336/EEC) "EMV Guidelines".

According to norm:
EN 292-1, EN 292-2, EN 349, EN 1050,
EN 61000-6-1, EN 61000-6-3
CH-8953 Dietikon, 11.10.2005

Sales Manager General Manager Products
Packaging Technology: Packaging Technology:



R. Kieffer

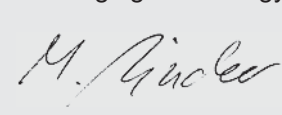

M. Binder

2

GENERAL INFORMATION

These operating instructions are intended to simplify familiarisation with the strapping tool and its proper use for the intended purpose. The operating instructions contain important information concerning the safe, proper and efficient use of the strapping tool. Compliance with the instructions will help to avoid danger, reduce repairs and stoppages and increase the reliability and service life of the strapping tool.

The operating instructions must always be available at the place of operation of the strapping tool. They must be read and observed by all persons concerned with work on the strapping tool. This work specifically includes operation, refilling of operating material, fault elimination and maintenance.

In addition to the operating instructions and the regulations for accident prevention effective in the country of use and place of application, the recognised technical regulations for safety and proper operation must also be observed.



CAUTION!

Used where there is danger to life and health.



WARNING!

Used for danger which can cause material damage.



NOTE!

Used for general information and information which, if not followed can cause faults in the operating sequence.

2.1 INFORMATION ON ENVIRONMENTAL PROTECTION

This tool is manufactured without any physical or chemical substances which could be dangerous to health.

For disposal of all the parts, the governmental instructions must be observed. The electrical assemblies should be dismantled so that the mechanical, electro-mechanical and electronic components can be disposed of separately.

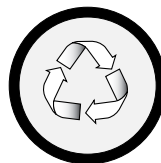

Dealers provide an environmentally-friendly battery disposal service

- Do not open the battery.
- Do not throw the used battery into household waste, fire or water.

Defective or used batteries undergo a complete recycling process.

3

SAFETY INSTRUCTIONS



Inform yourself!
Read the operating instructions carefully. Preventive and corrective maintenance on the tool may only be carried out by trained personnel.



Protect yourself!
When operating the tool, wear eye, face and hand protection (cut-proof gloves).



Power source!
Before starting preventive or corrective maintenance, remove battery from the tool.



Warning:
Strap will snap forward!
When cutting the strap, hold the upper portion and stand safely away from the strap.
Caution:
The lower strap will snap forward.



Warning:
Strap could break!
Do not stand in line with the strap while it is tensed. The strap could break!



Caution:
Only strap packed goods!
Do not put hands or other parts of the body between the strap and the package during the strapping process.



Caution:
Danger of squeezing!
Do not put your fingers into the tension wheel area.



Do not use water!
Do not use water or steam to clean the tool.



Original ORGAPACK spare parts must be used exclusively!
Not using original spare parts will dissolve the warranty and the liability.

Use for the intended purpose

This tool is designed for strapping packages, pallet loads and the like.

The tool was designed and manufactured to provide safe handling during the strapping operation.

The tool is designed for use with plastic straps (polypropylene and polyester).

Possible misuse

The use of steel straps is not possible.

3.1 SAFETY INSTRUCTIONS FOR BATTERY CHARGER AND BATTERY



Always inspect the electrical plug and cable before use. If damaged, they must be replaced by qualified personnel.

- Do not charge other types of batteries (see chapter 5.1) and use original accessories only.
- Keep the battery charger slot free of foreign objects and protect against dirt.
- Protect the battery charger against humidity and use it in dry areas only.
- Do not open the battery. Protect the battery against impact, heat and fire. Risk of explosion!
- When the battery is outside the battery charger, cover its battery terminals to avoid short circuits with metal objects. Risk of fire and explosion!
- Keep battery dry and protected against frost. Do not store it at temperatures over 50°C or below 10°C.
- Damaged batteries should not be used longer.

4

DESCRIPTION

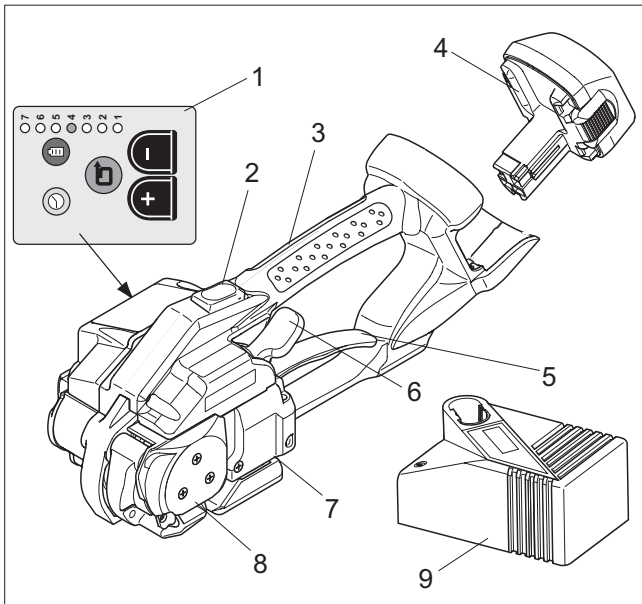

Fig. 1

4.1 CONSTRUCTION

- 1 Operating panel
- 2 Strap tensing push button
- 3 Handle
- 4 Battery
- 5 Rocker lever
- 6 Welding/cutting button
- 7 Welding/Cutting
- 8 Tensioning
- 9 Battery charger

4.2 OPERATING PANEL

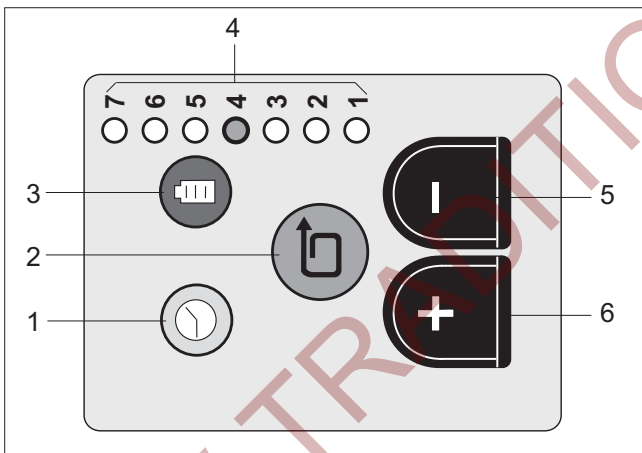



Fig. 2

- 1 Welding time push button
- 2 Strap tension push button
- 3 Battery push button
- 4 LED-indicators 1-7
Green = Strap tension setting
Red = Battery empty indicator
- 5 Setting - push button
- 6 Setting + push button

 For detailed information of the operating panel, refer to chapter 6.3.

4.3 FUNCTION

- Clamping of the straps by tooth plate on rocker (3/1).
- Tensioning by feed wheel (3/2) anti-clockwise.
- Friction welding (3/3) of the straps.
- Upper strap is cut by knife (3/4).

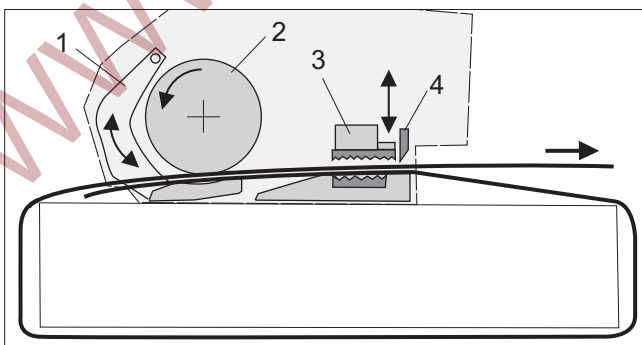







Fig. 3

4.4 BATTERY CHARGER INDICATORS

- Continuous green light**  **Ready for charging**
Battery not inserted, mains supply is connected.
- Flashing green light**  **Rapid charging**
Rapid charging operates until the battery is fully recharged. The battery charger then switches automatically to trickle charging.
- Continuous green light**  **Trickle charging**
Battery is fully charged.
The battery charger is delivering only a trickle charge.
- Double flashing green light**  **Temperature Warning:** the battery is too hot (or too cold). Trickle charging only.
The battery charger switches automatically to rapid charging when the temperature is within the permitted range again.
- Flashing green light**  **Error message**
Warning: battery cannot be charged (battery or temperature sensor defective or not a BOSCH battery).
- No indicator illuminated** Mains supply not connected: electrical plug, cable or battery charger defective.

 For detailed information, refer to the operating instructions for the battery charger.

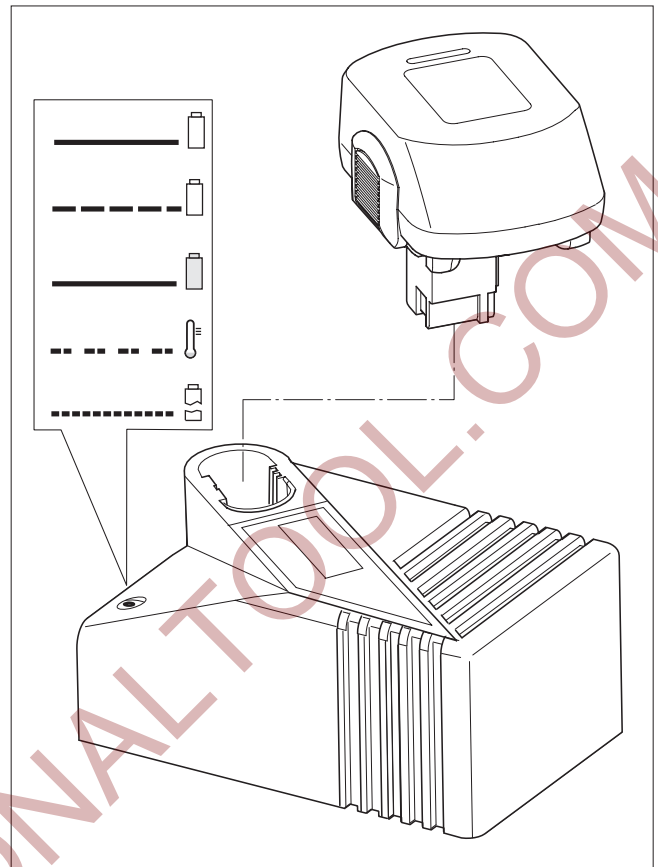

Fig. 4

5

INITIAL OPERATION

Input 230 V 50/60 Hz / 44 W
Output 7.2-14.4 V --- 1.9 A

Fig. 5

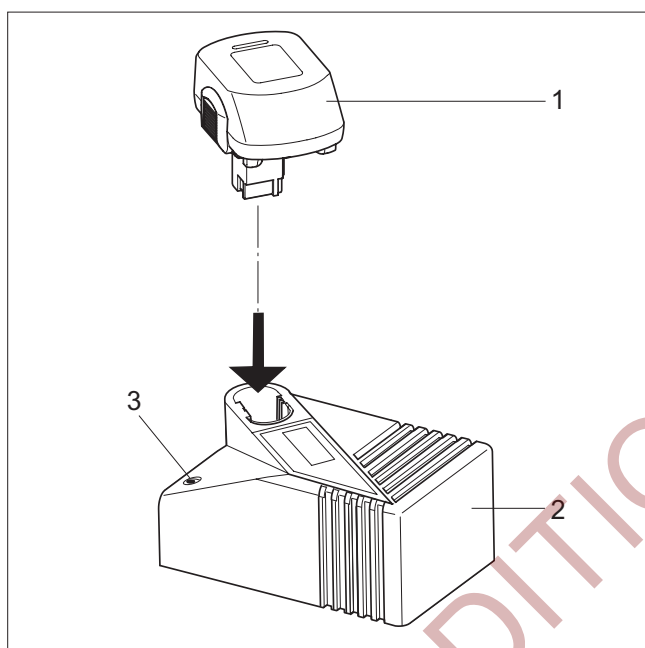



Fig. 6

5.1 BATTERY CHARGER

The mains supply must comply with the specifications on the rating plate (Fig. 5).

The battery charger is suitable only for charging batteries from the Bosch range of tools (NiCd/NiMH) with voltages between 7.2 V and 14.4 V.

5.2 FIRST BATTERY CHARGE

 Please observe the following points in order to ensure optimum battery life:

- Connect battery charger (6/2) to mains supply.
- Insert battery (6/1) into battery charger slot.

For the first charge, leave the battery in the charger for at least five hours, regardless of the battery indicator (the charging time for all subsequent charges is about 60 minutes).

For all subsequent charges, only recharge the battery when the LED indicator on the tool indicates battery empty (see Chapter 6.3). Avoid charging when the battery is not yet discharged. This will ensure optimum battery capacity and life.

Maximum battery output will be reached after four or five charging/discharging cycles.

5.3 CHARGING THE BATTERY

The charging process and error functions are indicated by a green light (6/3) (see chapter 4.4).

The charging time is approximately 60 minutes.

The maximum charging current flows when the temperature of the battery is between 15–40°C. Avoid charging the battery at temperatures below 0°C and above 40°C.

 **If the battery is not to be used for a longer period (several days), it should be removed from the tool and charged/stored in the battery charger.**

The intelligent charger with fuzzy control charges the battery with the optimum rapid charging current, depending on temperature and capacity. If fully charged, a preserving charge will prevent self-discharge and thus guarantee a long battery life.

6

OPERATING INSTRUCTIONS

6.1 OPERATING THE TOOL

- Insert charged battery (7/1) into strapping tool.
- Place strap round goods to be packaged, so that the straps lie one above the other on top of package. The beginning of the strap is underneath. Hold the straps with the left hand so that the strap beginning is approximately 20 cm (8") ahead of the hand.

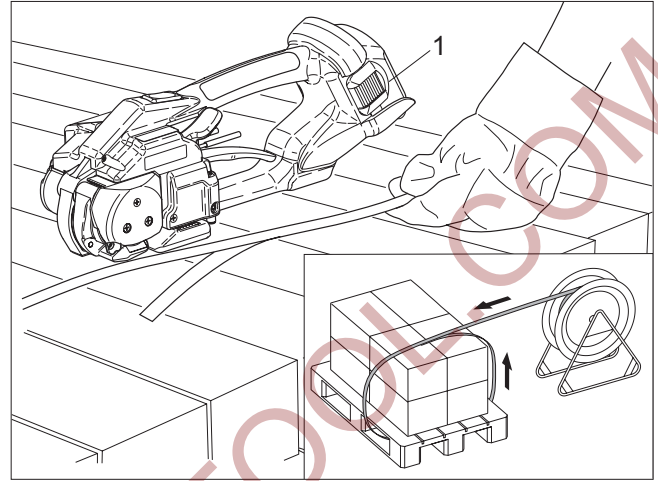



Fig. 7 Place strap around package

- Take the tool in the right hand and lift the rocker lever (8/1) towards the handle.
- Slide the straps, one on top of the other, into the tool up to the stop.

 The strap lead is now approximately 5 cm (2") beyond the tool.

- Release the rocker lever.

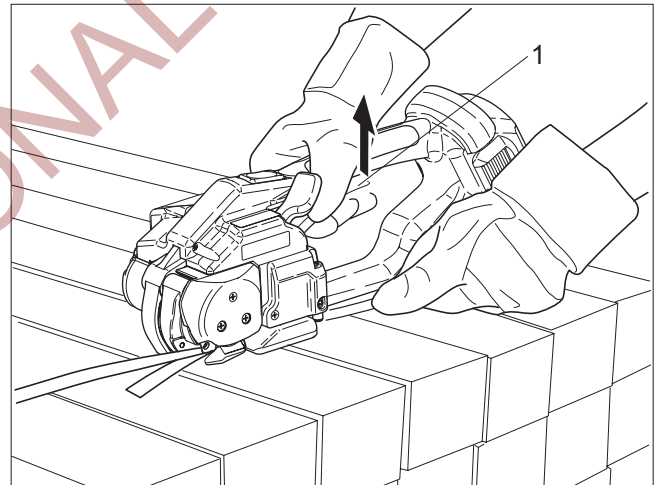



Fig. 8 Slide straps into tool

- Press the push button (9/1). The strap is tensioned until the required or pre-selected strap tension is reached.
- **The strap tension can be adjusted on the operating panel (see Chapter 6.3.2).**
- The strap can be re-tensioned at any time.

Releasing strap tension

In order to release the strap tension after the tensioning process, lift rocker lever (8/1) against handle.

 **Tensioning – welding:**
The welding may also be started before the strap has been tensioned. However, the tensioning button must be pressed **briefly** before welding.

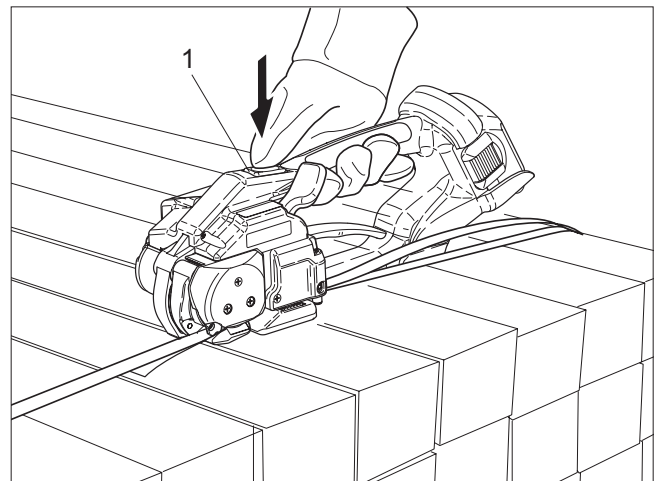

Fig. 9 Strap tensioning

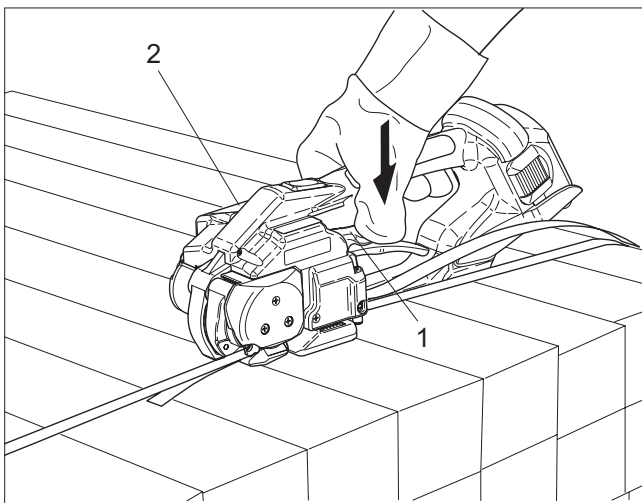
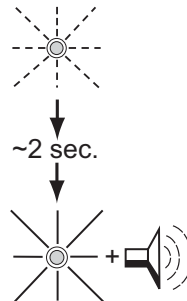

Fig. 10 Welding straps

- Depress button (10/1) completely to the stop. The straps are welded together and the upper strap is cut off. The LED indicator (10/2) indicates the cooling time of the sealing:



LED flashing

After finishing the friction welding, the green LED flashes for approx. two seconds. Do not remove the tool during this time!

Continuous LED and audible signal

The sealing cycle is finished.

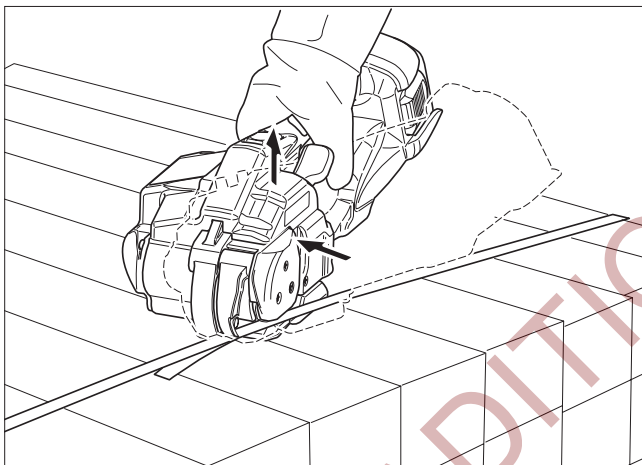



Fig. 11 Removing tool

- After the LED has stopped flashing and the audible signal sounds, raise the rocker lever up to the handle.
- Swing the tool away from the strapping backwards and to the right.
- Check the seal (refer to chapter 6.2).

 If the tool is used in a dirty environment, it is recommended that it should be cleaned daily. In particular the tension wheel and the tooth plate should be checked for damage and kept clean. This is best performed by blasting with compressed air (wear goggles).

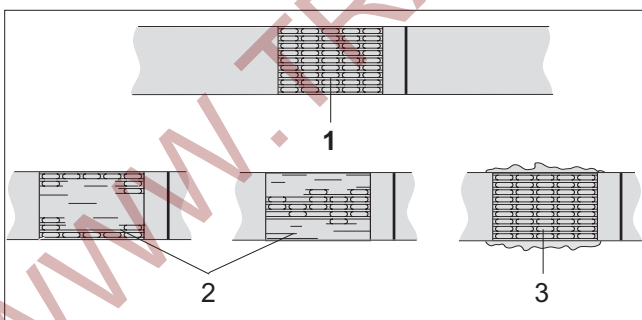

Fig. 12 Checking of seal

6.2 CHECKING THE SEAL

- Check appearance of seal (see fig. 12) regularly. If the straps are poorly welded, **check the welding time setting (refer to chapter 6.3.3).**

- 1 Good seal** (the complete surface is cleanly welded without excess material being forced out sideways).
- 2 Poorly welded seal** (not welded over the complete surface), welding time too short.
- 3 Poorly welded seal** (excess material is forced out sideways), welding time too long.



An incorrectly welded strapping cannot secure the package and can thus lead to injuries.

Never transport or move packaged goods with incorrectly welded seals.

6.3 OPERATING PANEL

a) Standard indication (green)

The current strap tension setting is monitored with inserted and charged battery.

1 = minimum strap tension (approx. 100 N)

7 = maximum strap tension (approx. 700 N)

– For adjustment of strap tension, refer to chapter 6.3.2.

b) Battery empty indication (red)

If the inserted battery is empty, the LED switches to red and the battery must be charged, refer to chapter 5.3.

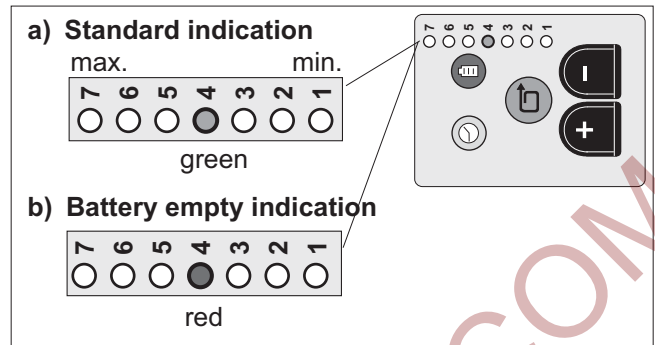

Fig. 13

6.3.1 CHECKING BATTERY CHARGE

– Depress battery push button (14/1) briefly. Read off battery charge on LED indicator (14/2).

1 = empty battery

1–3 = minimum charge (battery must be charged soon)

1–5 = decreasing charge (charging possible)

1–6 = good charge (charging would damage the battery)

1–7 = maximum battery charge (charging would damage the battery)

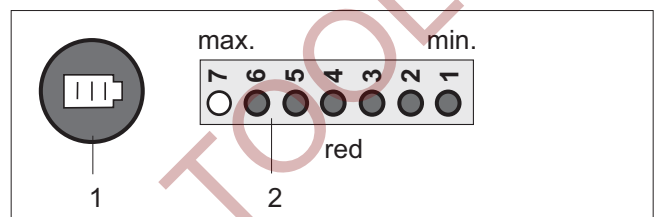

Fig. 14

6.3.2 SETTING STRAP TENSION

– Depress strap tension push button (15/1) briefly until LED indicator (15/3) flashes.

– Depress – or + push button (15/2) until flashing LED indicator shows required strap tension (wait two seconds until new setting is saved).

1 = minimum strap tension (ca. 100 N)

7 = maximum strap tension (ca. 700 N)

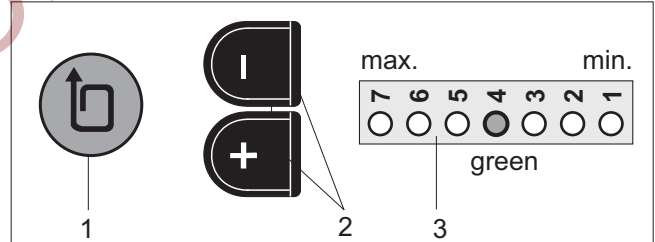

Fig. 15

6.3.3 SETTING WELDING TIME

– Depress welding time push button (16/1) briefly until LED indicator (16/3) flashes.

– Depress – or + push button (16/2) until flashing LED indicator shows required welding time (wait two seconds until new setting is saved).

1 = minimum welding time

7 = maximum welding time

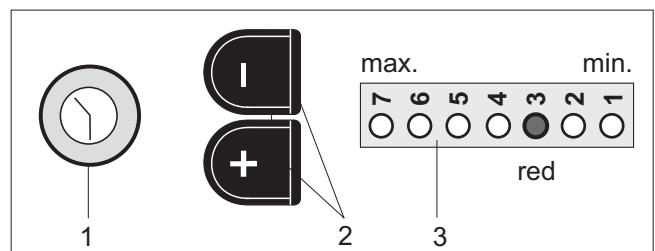

Fig. 16

Cutting:

The cutting of the strap is influenced by the welding time. If the tool cuts badly, extend the welding time by one interval.

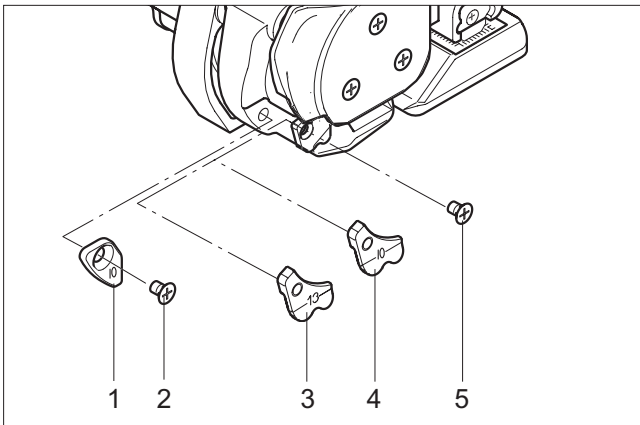

Fig. 17

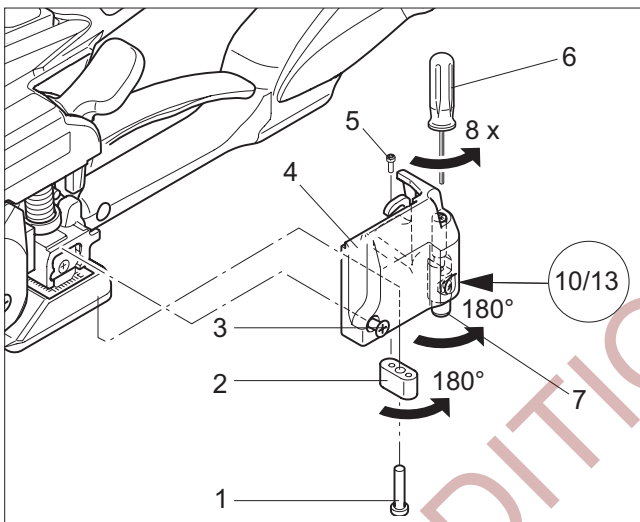

Fig. 18

6.4 SETTING STRAP WIDTH



The tool can be used with two different strap widths 9–11 mm ($\frac{3}{8}$ ") or 12–13 mm ($\frac{1}{2}$ ").
Strap width 12–13 mm ($\frac{1}{2}$ ") only for PP straps!

a) Change strap width from 9–11 mm to 12–13 mm

- Remove battery from tool.
- Release sunk screw (17/2) and remove strap stop 10 mm (17/1) (12–13 mm without strap stop).
- Lift the rocker lever towards the handle, release sunk screw (17/5) and remove strap guide 10 mm (17/4). Mount strap guide 13 mm (17/3). Secure sunk screw (17/5) with Loctite 222.

- Release sunk screw (18/3) and cylinder screw (18/1) and remove cover (18/4).
- Release cylinder screw (18/5) turn strap stop (18/2) 180° and remount it.
- Unscrew threaded bolt eight turns with screwdriver (18/6).
- Pull down strap guide (18/7) and turn it 180° until 13 mm indicator appears.
- Tighten threaded bolt with screwdriver (18/6) and mount cover (18/4).
- Secure screws (18/1) and (18/3) with Loctite 222.

b) Change strap width from 12–13 mm to 9–11 mm

- Sequence as described under point a).
- Mount 10 mm strap stop (17/1) and secure sunk screw (17/2) with Loctite 222.
- Mount 10 mm strap guide (17/4) and secure sunk screw (17/5) with Loctite 222.
- Turn strap stop (18/2).
- Turn strap guide (18/7) until "10" indicator appears.

7

PREVENTIVE AND CORRECTIVE MAINTENANCE

7.1 CLEANING/REPLACING TENSION WHEEL

Removal

- Remove battery from tool.
- Release three sunk screws (19/2) and remove cover (19/3) with ball bearing.
- Lift rocker lever (19/4) and remove tension wheel (19/1).
- Clean the tension wheel with compressed air (wear goggles).
- If the tension wheel teeth are covered with heavy dirt, they must be carefully cleaned with the wire brush supplied.
- Check tension wheel for worn teeth. If a few teeth are broken, replace tension wheel (observe rotating direction, see arrow)



The tension wheel must not be cleaned while it is rotating. There is a risk of breaking teeth!

Installation

- Install the parts in reverse order.
- Grease gear teeth of tension wheel **lightly** with Klüber grease GBU Y 131 (Microlube).
- When mounting tension wheel lift rocker lever.
- Secure sunk screw (19/2) with Loctite 222.



All preventive maintenance tasks can be performed with a Phillips screw driver!

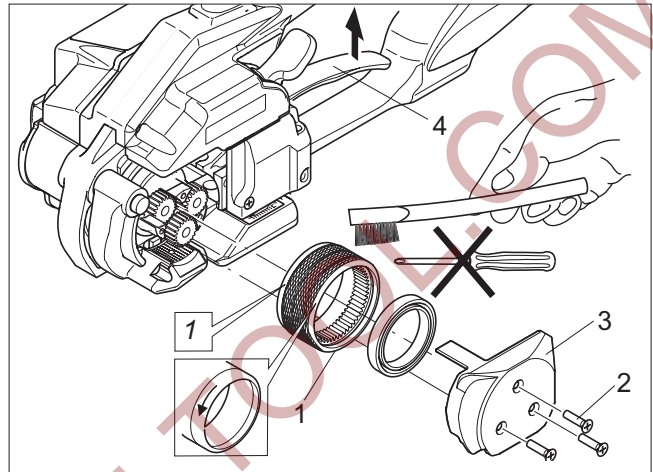

Fig. 19 (1 = Tension wheel type for OR-T 100)

7.2 CLEANING/REPLACING TOOTH PLATE

Removal

- Remove battery from tool.
- Release sunk screw (20/1) and remove tooth plate (20/2).
- Clean tooth plate with compressed air (wear goggles).
- If the tooth plate teeth are covered with heavy dirt, they must be carefully cleaned with the wire brush supplied or a sharp tool.
- Check tooth plate for worn teeth, if necessary replace tooth plate.

Installation

- Install the parts in reverse order.
- Secure sunk screw (20/1) with Loctite 222.

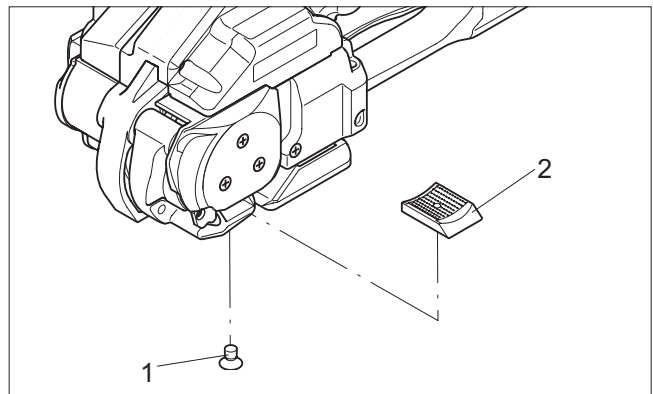

Fig. 20

7.3 REPLACING CUTTING KNIFE

Removal

- Remove battery from tool.
- Release sunk screw (21/2) and cylinder screw (21/1) and remove cover (21/3).
- Release cylinder screw (21/6) and remove cutting knife (21/4) with flanged bushing (21/5). Replace cutting knife.

Installation

- Install the parts in reverse order.
- Before install cutting knife, check that the compressing spring on top of knife is still mounted.
- Secure screw (21/1), (21/2) and (21/6) with Loctite 222.

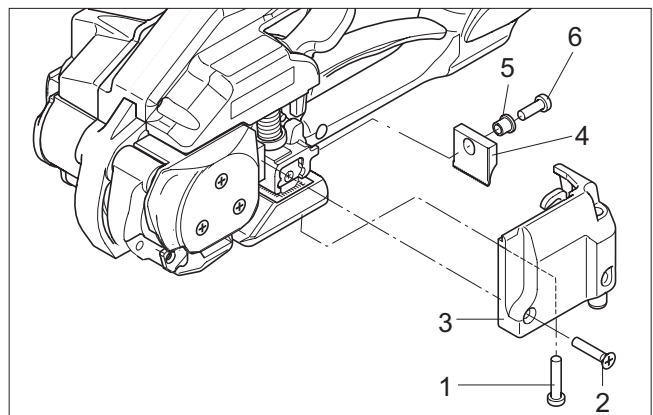

Fig. 21

8

		Empfohlene Ersatzteile	Recommended spare parts	Pièces de rechange recommandées	Parti di ricambio consigliate	
		Bei Bestellungen immer Artikel-Nr. angeben	When ordering please indicate part number	Lors d'une commande, veuillez indiquer le numéro d'article	Nelle ordinazione indicare sempre il numero dell'articolo	
Pos.	Artikel-Nr. Part no No d'article Art. nr.	Benennung	Part name	Article	Articolo	Stück Quantity Pièce Pezzi
38	1821.047.007	Spannrad	Tension wheel	Molette de tension	Rueda tensora	1
46	1821.048.010	Zahnplatte	Tooth plate	Plaque dentée	Piastra dentata	1
95	1821.209.021	Messer	Cutter knife	Couteau de coupe	Coltello	1

		8.1 Teileliste 1832.002.018/1.11	8.1 Parts list	8.1 Liste des pièces	8.1 Lista delle parti	
		Bei Bestellungen immer Artikel-Nr. angeben	When ordering please indicate part number	Lors d'une commande, veuillez indiquer le numéro d'article	Nelle ordinazione indicare sempre il numero dell'articolo	
1	1832.011.130	Grundplatte komplett, inkl. Pos. 3-5	Base plate complete, incl. pos. 3-5	Plaque de base, complète, incl. pos. 3-5	Piastra di base completa, incl. pos. 3-5	1
2						
3	1935.510.150	Radial-Gleitlager, Ø10/12 x 15	Slide bearing	Palier lisse	Cuscinetto liscio, assiale	2
4	1935.512.080	Radial-Gleitlager, Ø12/14 x 8	Slide bearing	Palier lisse	Cuscinetto liscio, assiale	2
5	1921.308.521	Zylinderstift, Ø 8h6 x 55	Cylinder pin	Goujon cylindrique	Spina cilindrica	1
6						
7	1832.022.109	Zahnplatte unten	Tooth plate below	Plaque dentée en bas	Piastra dentata in basso	1
8	1832.022.055	Gewindestift	Set screw	Goujon fileté	Perno filettato	1
9						
10	1821.061.009	Kegelrad mit Ritzel	Bevel wheel with pinion	Roue conique avec pignon	Coppia di ruote coniche con ruota	1
11						
12	1930.190.154	Rillenkugellager, Ø15/28 x 7	Ball bearing	Roulement à billes	Cuscinetto	1
13	1832.039.174	Distanzring	Spacer ring	Anneau d'écartement	Anello distanziatrice	1
14	1832.039.184	Sperrrad komplett, inkl. Pos. 16, 17	Blocking wheel complete, incl. pos. 16, 17	Rouleau de verrouillage, incl. pos.16, 17	Ruota di blocco completa, incl. pos 16.17	1
15						
16	1933.710.100	Nadelhülse, Ø10/14 x 10	Needle bushing	Douille d'aiguille	Bussola ad aghi	1
17	1926.501.100	Hülsenfreilauf, Ø10/14x12	Free-wheel needle bearing	Roue libre à aiguilles	Cuscinetto ad aghi ruota libera	1
18	1930.190.102	Rillenkugellager, Ø10/22 x 6	Ball bearing	Roulement à billes	Cuscinetto	1
19	1920.210.102	Sicherungsring, Ø10	Retaining ring	Circlip	Anello di sicurezza	1
20	1917.401.105	Distanzscheibe, Ø10/22 x 0,5	Spacer disk	Disque d'écartement	Rondella distanziatrice	1
21						
22	1821.060.020	Planetenrad, 1.Stufe	Planetary wheel, 1st step	Roue planétaire, 1re étage	Ruota planetaria, 1° stadio	3
23	1832.039.165	Planetenträger komplett	Planetary support complete	Support pour planétaire complet	Porta planetari completo	1
24						

Pos.	Artikel-Nr. Part no No d'article Art. nr.	Benennung	Part name	Article	Articolo	Stück Quantity Pièce Pezzi
25						
26						
27	1933.710.150	Nadelhülse, Ø10/14 x 15	Needle bushing	Douille à aiguilles	Bussola ad aghi	1
28	1917.401.125	Distanzscheibe, Ø12/24 x 0.5	Spacer disk	Disque d'écartement	Rondella distanziatrice	1
29						
30	1832.039.182	Flansch komplett	Flange complete	Bride complète	Flangia completa	1
31						
32						
33						
34	1911.004.124	Zylinderschraube, M4x12	Cylinder screw	Vis cylindrique	Vite cilindrica	5
35	1832.039.185	Nockenscheibe	Cam disk	Disque à came	Rondella a camme	1
36	1930.180.356	Rillenkugellager, Ø35/47 x 7	Ball bearing	Roulement à billes	Cuscinetto	2
37	1821.060.014	Planetenrad, 2.Stufe	Planetary wheel, 2nd step	Roue planétaire, 2me étage	Ruota planetaria, 2° stadio	3
38	1821.047.007	Spannrad	Tension wheel	Molette de tension	Rueda tensora	1
39						
40	1832.031.029	Wippe	Rocker	Bascule	Bilanciere	1
41	1832.031.033	Anschlag	Stop	Butée	Dispositivo d'arresto	1
42	1921.304.100	Zylinderstift, Ø4m6 x 10	Cylinder pin	Goujon cylindrique	Spina cilindrica	1
43	1832.031.030	Bandanschlag vorne, 10 mm	Strap stop, front, 10 mm	Butée pour bande, avant, 10 mm	Guida reggia, posteriore, 10 mm	1
44						
45	1914.303.088	Senkschraube, M3 x 8	Counter sunk screw	Vis noyée	Vite a testa svasata	6
46	1821.048.010	Zahnplatte	Tooth plate	Plaque dentée	Piastra dentata	1
47	1911.804.064	Senkschraube, M4 x 6	Counter sunk screw	Vis noyée	Vite a testa svasata	3
48						
49	1821.140.036	Motor komplett	Motor complete	Moteur complet	Motore completo	1
50						
51						
52						
53	1832.039.188	Träger	Carrier	Support	Sostegno	1
54	1930.180.152	Rillenkugellager, Ø15/24 x 5	Ball bearing	Roulement à billes	Cuscinetto	3
55	1832.039.187	Zahnriemenrad komplett, inkl. Pos. 54, 57	Toothed belt wheel complete, incl. pos. 54,57	Roue courroie dentée compl., incl. 54, 57	Rueda cinghia dentata completo, incl. pos. 57	1
56						
57	1926.501.060	Hülsenfreilauf, Ø6/10 x 12	Bushing	Douille	Ruota libera	1
58	1821.061.012	Kegelritzel komplett, inkl. Pos. 54, 60	Bevel wheel complete, incl. pos. 54, 60	Roue conique complète, incl. pos. 54, 60	Coppia di ingranaggi conici compl., incl. pos. 60	1
59						
60	1926.502.060	Hülsenfreilauf, Ø6/10 x 15	Bushing	Douille	Ruota libera	1
61						

Pos.	Artikel-Nr. Part no No d'article Art. nr.	Benennung	Part name	Article	Articolo	Stück Quantity Pièce Pezzi
62						
63	1832.022.121	Lagerbüchse komplett, inkl. Pos. 77	Bushing complete, incl. pos. 77	Palier complet, incl. pos. 77	Bronzina completo, incl. pos. 77	1
64						
77	1922.103.083	Passkerbstift, Ø3x8 DIN 1469	Ridget pin	Goupille cannelée	Spina scanalata	1
65	1933.712.120	Nadelhülse, Ø12/18 x 12	Needle bushing	Douille à aiguilles	Bussola ad aghi	1
66	1930.190.122	Rillenkugellager, Ø12/24 x 6	Ball bearing	Roulement à billes	Cuscinetto	1
67	1920.324.124	Sicherungsring V Typ J Ø24	Retaining ring	Circlip	Anello di sicurezza	1
68	1832.022.119	Exzenterwelle	Eccentric shaft	Arbre excentrique	Albero ad eccentrico	1
69	1832.022.102	Ritzel	Pinion	Pignon	Ruota ad ingranaggio	1
70	1832.022.103	Scheibe	Disk	Disque	Rondella	1
71						
72	1911.005.124	Zylinderschraube, M5 x 12	Cylinder screw	Vis cylindrique	Vite cilindrica	2
73	1821.067.008	Zahnriemen	Tothed belt	Courroie dentée	Cinghia dentata	1
74	1911.005.204	Zylinderschraube, M5 x 20	Cylinder screw	Vis cylindrique	Vite cilindrica	3
75	1832.022.084	Schwenklager komplett, inkl. Pos. 77	Swivel bearing complete, incl. pos. 77	Palier pivotant complet, incl. pos. 77	Cuscinetto completo orientabile, incl. pos. 77	1
76						
77	1922.103.083	Passkerbstift, Ø3x8 DIN 1469	Ridget pin	Goupille cannelée	Spina scanalata	1
78	1821.011.020	Zugfeder	Tension spring	Ressort à tension	Molla di torsione	1
79	1920.223.124	Sicherungsring V Typ A Ø23	Retaining ring	Circlip	Anello di sicurezza	1
80	1920.212.102	Sicherungsring Typ A Ø12	Retaining ring	Circlip	Anello di sicurezza	1
81	1832.022.120	Pleuel	Connecting rod	Bielle	Biella	1
82	1832.022.058	Achse	Shaft	Axe	Asse	1
83	1930.110.092	Rillenkugellager, Ø9/26 x 8	Ball bearing	Roulement à billes	Cuscinetto	1
84	1821.020.104	U-Scheibe	Washer	Rondelle	Rondella	1
85	1911.004.104	Zylinderschraube, M4x10	Cylinder screw	Vis cylindrique	Vite cilindrica	2
86	1912.203.086	Senkschraube, M3 x 8	Counter sunk screw	Vis noyée	Vire a testa svasata	2
87	1832.022.044	Schweissschuh	Welding shoe	Patin de soudage	Soarpino di saldatura	1
88	1912.403.054	Linsenschraube, M3 x 5	Oval head screw	Vis à tête bombée	Vite a testa bombata	1
89	1832.022.059	Sicherungsblech	Safety plate	Tôle de sécurité	Lamiera di sicurezza	1
90	1832.022.050	Kugelführung	Ball guide	Guide à billes	Guida a sfere	2
91	1832.022.045	Abdeckplatte	Cover plate	Plaque de couverture	Lamiera di ricoprimento	1
92						
93	1832.022.046	Zahnplatte oben	Tooth plate top	Plaque dentée en haut	Piastra dentata sopra	1
94	1821.010.059	Druckfeder	Compression spring	Ressort à pression	Molla di compressione	1
95	1821.209.021	Messer	Cutter knife	Couteau de coupe	Coltello	1
96	1832.022.049	Bundbüchse	Flanged bushing	Douille à épau	Bussola d'unione	1
97						
98						

Pos.	Artikel-Nr. Part no No d'article Art. nr.	Benennung	Part name	Article	Articolo	Stück Quantity Pièce Pezzi
99						
100	1832.011.116	Deckel Spannen	Cover tensioning	Couvercle tension	Coperchio tensione	1
101						
102	1832.042.021	Bandführung, 13 mm	Strap guide, 13 mm	Guide de la bande, 13 mm	Guida reggia, 13 mm	1
103	1911.804.164	Senkschraube, M4 x 16	Counter sunk screw	Vis noyée	Vite a testa svasata	1
104	1832.042.025	Bandführung, 10 mm	Strap guide, 10 mm	Guide de la bande, 10 mm	Guida reggia, 10 mm	1
105	1911.804.126	Senkschraube, M4 x 12	Counter sunk screw	Vis noyée	Vite a testa svasata	3
106						
107						
108						
109	1832.031.032	Wippenhebel komplett, inkl. Pos. 111-113	Rocker lever complete, incl. pos. 111-113	Levier de basc. compl., incl. pos. 111-113	Leva del bilanciere completo, incl. pos. 111-113	1
110						
111	1821.031.051	Bolzen, Ø8/h9	Bolt	Goujon	Perno	1
112	1821.031.050	Stift, Ø4/h9 x 32.5	Pin	Goupille	Spina	1
113	1821.031.052	Stift, Ø4/h9 x 30	Pin	Goupille	Spina	1
114	1832.031.028	Sperrklinke	Blocking pawl	Cliquet de verrouillage	Nottolino di blocco	1
115	1821.031.049	Bolzen	Bolt	Goujon	Albero	1
116	1832.039.163	Zahnsegment	Toothed segment	Segment dentée	Supporto dentata	1
117	1917.411.105	Passscheibe, Ø10/16 x 0.5	Spacer disk	Rondelle de calibrage	Vite calibrata	2
118	1920.108.102	Sicherungsscheibe, Ø8	Retaining ring	Circlip	Rondella di sicurezza	1
119	1911.004.254	Zylinderschraube, M4x25	Cylinder screw	Vis cylindrique	Vite cilindrica	1
120	1821.036.003	Zugfederbolzen	Tension spring bolt	Goujon pour ressort à tension	Albero di molla di torsione	1
121	1821.011.021	Zugfeder	Tension spring	Ressort à tension	Molla di torsione	1
122						
123	1925.010.802	Kugel gehärtet, Ø8	Globule hardened	Bille trempé	Palla invecchiare	1
124	1821.010.052	Druckfeder	Compression spring	Ressort à pression	Molla di compressione	1
125	1832.011.156	Gewindbolzen, M10	Threaded bolt	Goujon fileté	Perno filettato	1
126						
127	1832.022.124	Schweisstasten-Set, inkl. Pos. 156	Welding button-set, incl. pos. 156	Touche soudage, incl. pos. 156	Tasto di saldatura, incl. pos. 156	1
128	1832.022.099	Kurvenbolzen	Bolt	Goujon	Albero	1
129						
130	1832.022.098	Kurve	Cam	Came	Camme	1
131	1910.605.084	Gewindestift, M5 x 8	Set screw	Goujon fileté	Perno filettato	1
132	1821.151.004	Mikroschalter, Schweißen	Micro switch, welding	Microinterrupteur, soudage	Micro interruttore, saldatura	1
133	1912.401.104	Linsenschraube, M2 x 10	Oval head screw	Vis à tête bombée	Vite a testa bombata	2
134	1832.031.043	Unterlegeplatte	Shim plate	Plaque entretoise	Piastra d'appoggio	1
135	1832.022.091	Federbügel	Spring bow	Bride à ressort	Molla	1

Pos.	Artikel-Nr. Part no No d'article Art. nr.	Benennung	Part name	Article	Articolo	Stück Quantity Pièce Pezzi
136	1832.022.092	Rolle	Roller	Rouleau	Rullo	1
137	1832.022.093	Achse	Shaft	Axe	Asse	1
138	1832.022.094	Druckbolzen	Pressure bolt	Goujon à pression	Albero di pressione	1
139	1821.010.056	Schraubenfeder	Spring	Ressort	Molla	1
140	1916.306.062	Sicherheitsmutter, M6	Lock nut	Ecrou de sécurité	Dada de sicurezza	1
141	1920.104.072	Sicherungsscheibe, Ø4	Retaining ring	Circlip	Anello di sicurezza	2
142	1821.030.033	Achse	Shaft	Axe	Asse	1
143						
144						
145						
146	1832.011.117	Deckel Schweissen	Cover welding	Couvercle soudage	Coperchio saldatura	1
147	1832.042.022	Bandführung, 10/13 mm	Strap guide, 10/13 mm	Guide de la bande, 10/13 mm	Guida reggia, 10/13 mm	1
148	1832.042.024	Bandanschlag, 10/13 mm	Strap stop 10/13 mm	Butée de la bande 10/13 mm	Arresto reggia 10/13 mm	1
149	1832.042.023	Haken	Hook	Crochet	Gancio	1
150	1832.042.018	Gewindebolzen	Threaded bolt	Goujon fileté	Perno filettato	1
151	1832.042.020	Stiftschraube	Pin screw	Vis à goujon	Spinotto filettato	1
152	1821.010.057	Druckfeder	Compression spring	Ressort à pression	Molla di compressione	1
153	1914.635.250	PT-Schraube, KA 35 x 25	PT-Screw	Vis PT	Vite PT	1
154	1914.630.140	PT-Schraube, KA 30 x 14	PT-Screw	Vis PT	Vite PT	1
155	1832.011.119	Getriebedeckel	Gear cover	Couvercle d'engrenage	Cassa del cambio	1
156	1912.404.104	Linsenschraube, M4 x 10	Oval head screw	Vis à tête bombée	Vite a testa bombata	6
157						
158	1832.011.124	Gehäuseschale rechts, blau	Housing part right, blue	Coffrage droite, bleu	Involucro destro, blu	1
159						
160	1832.011.122	Gehäuseschale links, blau	Housing part left, blue	Coffrage gauche, bleu	Involucro sinistro, blu	1
161						
162	1914.635.200	PT-Schraube, KA 35 x 20	PT-Screw	Vis PT	Vite PT	10
163						
164	1832.011.102	Schutzplatte	Protection plate	Plaque de protection	Piastra de protezione	1
165						
166	1832.011.101	Schaltertaste, gelb	Switch button, yellow	Bouton de commande, jaune	Scatola dell'interruttore, giallo	1
167	1821.010.054	Druckfeder	Compression spring	Ressort à pression	Molla di compressione	1
168	1821.151.003	Mikroschalter, Spannen	Micro switch, tensioning	Microinterrupteur, serrage	Micro interruttore, tendere	1
169						
170	1832.011.132	Motorverschaltung komplett, blau	Motor cover complete, blue	Coffrage du moteur complète, bleu	Copperchio del motore completa, blu	1
171	1821.152.038	Kontaktplatte	Contact plate	Plaque de contact	Placca a contatto	1
172	1821.152.043	Steuerprint digital	Printed circuit board digital	Carte circuit imprimé numérique	Circuito stampato digitale	1

Pos.	Artikel-Nr. Part no No d'article Art. nr.	Benennung	Part name	Article	Articolo	Stück Quantity Pièce Pezzi
173	1914.630.100	PT-Schraube, KA 30x10	PT-Screw	Vis PT	Vite PT	2
174						
175	1917.803.031	U-Scheibe, M 3	Washer	Rondelle	Rondella	2
176	2179.150	Akku 12V 2,4 Ah	Battery	Accumulateur	Accumulatore	1
177	2179.250	Schnell-Ladegerät AL 60DV 1419, EU	Charger	Chargeur	Caricatore	1
177	2179.251	Schnell-Ladegerät AL 60DV 1419, USA	Charger	Chargeur	Caricatore	1
177	2179.252	Schnell-Ladegerät AL 60DV 1419, Japan	Charger	Chargeur	Caricatore	1
180	1821.092.016	Hinweisschild, CE	Indication plate	Plaque indicatrice	Targhetta	1
181	1821.092.013	Hinweisschild, Sicherheit	Indication plate	Plaque indicatrice	Targhetta	1
182	1821.092.029	Hinweisschild, Spannrade	Indication plate	Plaque indicatrice	Targhetta	1
183	1821.090.021	Firmenschild	Name plate	Plaque maison	Targhetta	1
184	1821.091.020	Typenschild	Type plate	Plaque de type	Placcetta de tipo	1
185	1821.092.017	Hinweisschild, 1	Indication plate	Plaque indicatrice	Targhetta	1
186	1821.092.018	Hinweisschild, 2	Indication plate	Plaque indicatrice	Targhetta	1
	1821.901.005	Werkzeug-Set	Tool-set	Jeu de outil	Serie di utensili	
190	1821.901.003	Kreuzschlitz-Schraubenzieher	Screwdriver (Phillips)	Tournevis (Phillips)	Cacciavite	1
191	1821.901.004	Stahldraht-Bürste	Wire brush	Brosse métallique	Spazzola metallica	1
192						
	2179.850	Option: Aufhängebügel-Set	Option: suspension bow-set	Option: jeu de crochet de suspension	Opzioni: serie d'arco di sospensione	
196	1832.061.006	Aufhängebügel	Suspension bow	Crochet de suspension	Arco di sospensione	1
197	1912.405.104	Linsenschraube, M 5 x 10	Oval head screw	Vis à tête bombée	Vite a testa bombata	1
198	1912.704.204	Linsenschraube, M 4 x 20	Oval head screw	Vis à tête bombée	Vite a testa bombata	1
200	2179.880	Option: Schutzabdeckung-Set	Option: protection cover-set	Option: jeu de couvercle de protection	Opzioni: serie coperchio di protezione	
	1832.042.027	Ersatzteil-Set: Bandführung 10 / 13 mm	Spare part-set: strap guide 10 / 13 mm	Pièces de rechange: guide de la bande	Parti di ricambio: guida reggia 10 / 13 mm	
43	1832.031.030	Bandanschlag vorne, 10 mm	Strap stop, front, 10 mm	Butée pour bande, avant, 10 mm	Guida reggia, posteriore, 10 mm	1
102	1832.042.021	Bandführung, 13 mm	Strap guide, 13 mm	Guide de la bande, 13 mm	Guida reggia, 13 mm	1
104	1832.042.025	Bandführung, 10 mm	Strap guide, 10 mm	Guide de la bande, 10 mm	Guida reggia, 10 mm	1
47	1911.804.066	Senkschraube, M 4 x 6	Counter sunk screw	Vis noyée	Vite a testa svasata	2
		Ersatzteil-Set: Gehäuseschalen	Spare part-set: housing parts	Pièces de rechange: pièces de bâti	Parti di ricambio: d'involucro	
	1832.011.128	Gehäuseschalen, blau, inkl. Pos. 158/160	Housing parts, blue, incl. pos. 158/160	Pièces de bâti, bleu, incl. pos. 158/160	Involucro, blu, incl. pos. 158/160	1

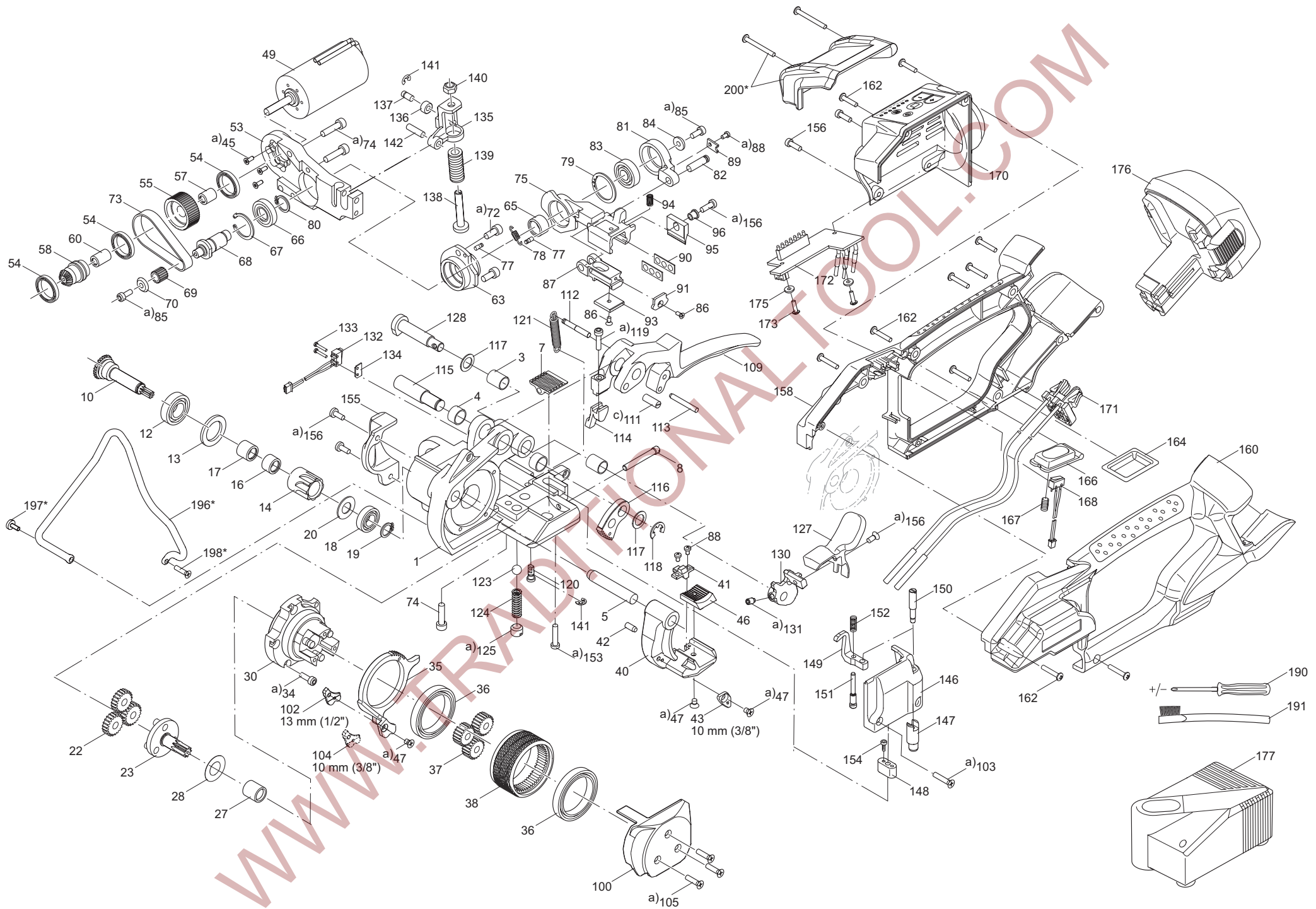

a) Loctite 222 b) Loctite 243 c) Loctite 638 *Optionen/Options
53

OR-T 100

1832.002.018/1.5

05.04.06 ak/hp

04.06/WE

For Parts & Service 1-877-862-6699