

BATTERY-POWERED
STRAPPING TOOL

HELIOS

H-451

IMPORTANT
Keep it

OPERATION, SAFETY
& SPARE PARTS
MANUAL

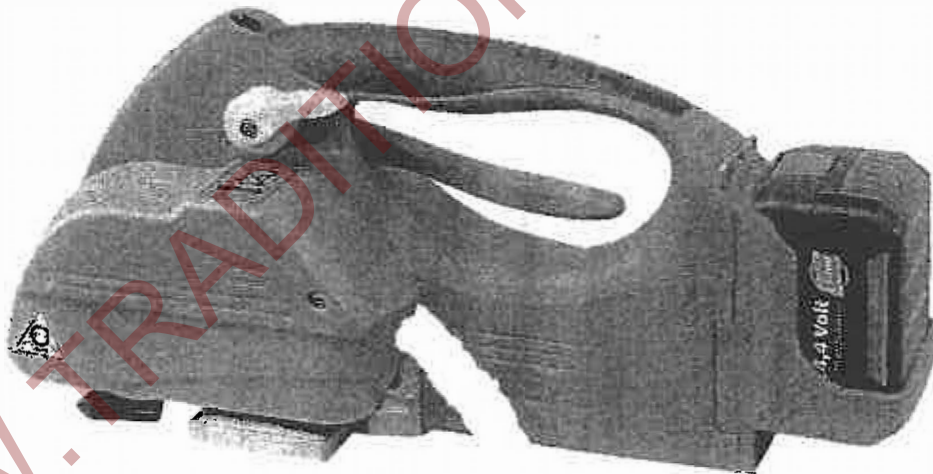

Read All Instructions Before Operating This Product

Original Instruction

WWW.TRADITIONALTOOL.COM

PART I

CONTENTS

1. General Safety Rules	1
2. Functional Unit	3
3. Technical Data	4
4. Operation Elements	4
5. Operation	5
6. Maintenance	9
7. Troubleshooting	10
8. Wiring Diagram	11

WWW.TRADITIONALTOOL.COM

1. General Safety Rules

Warning:

DO NOT attempt to operate the tool until you have read and understood all instructions and safety rules contained in this manual. Failure to comply may result in accidents involving fire, electric shock, or serious personal injury. Save this owner's manual for future reference and review it frequently for safe operation.

Work Area

- a. **Keep work area clean and well lit.** Cluttered and dark areas invite accidents.
- b. **Do not operate Power tools in explosive atmospheres, such as in the presence of flammable liquids, gases or dust.** Power tools create sparks which may ignite the dust or fumes.
- c. **Keep bystanders, children and visitors away while operating a tool.** Distractions can cause you to lose control.

Electrical Safety

- a. **Charger's plugs must match the outlet. Never modify the plug in any way. Do not use any adapter plugs with earthed (grounded) power tools.** Unmodified plugs and matching outlets will reduce risk of electric shock.
- b. **Avoid body contact with earthed or grounded surfaces such as pipes, radiators, ranges and refrigerators.** There is an increased risk of electric shock if your body is earthed or grounded.
- c. **Do not expose power tools to rain or wet conditions.** Water entering a power tool will increase the risk of electric shock.
- d. **Do not abuse the cord of charger. Never use the cord for carrying, pulling or unplugging the power tool. Keep cord away from heat, oil, sharp edges or moving parts.** Damaged or entangled cords increase the risk of electric shock.
- e. **When operating a power tool outdoors, use an extension cord suitable for outdoor use.** Use of a cord suitable for outdoor use reduces the risk of electric shock.

Personal Safety

- a. **Stay alert, watch what you are doing and use common sense when operating a tool. Do not use a tool while you are tired or under the influence of drugs, alcohol or medication.** A moment of inattention while operating power tools may result in serious personal injury.
- b. **Use personal protective equipment. Always wear eye protection.** Protective equipment such as dust mask, non-skid safety shoes, hard hat, or hearing protection used for appropriate conditions will reduce personal injuries.
- c. **Avoid accidental starting. Ensure the switch is in the off-position before insert Battery.** Carrying tools with your finger with the switch on invites accidents.
- d. **Remove any adjusting key or wrench before operation the tool.** A wrench or a key left attached to a rotating part of the tool may result in personal injury.
- e. **Do not overreach. Keep proper footing and balance at all times.** This enables

better control of the tool in unexpected situations.

- f. **Dress properly. Do not wear loose clothing or jewellery. Keep your hair, clothing and gloves away from moving parts.** Loose clothes, jewellery or long hair can be caught in moving parts.

Power Tool Use and Care

- a. **Do not use the tool if the switch does not turn it on and off.** Any tool that cannot be controlled with the switch is dangerous and must be repaired.
- b. **Take off the battery pack from the tool before making any adjustments, changing accessories, or storing tools.** Such preventive safety measures reduce the risk of starting the tool accidentally.
- c. **Store idle tools out of the reach of children and do not allow persons unfamiliar with the tool or these instructions to operate the tool.** Tools are dangerous in the hands of untrained users.
- d. **Maintain tools. Check for misalignment or binding of moving parts, breakage of parts and any other condition that may affect the tool's operation. If damaged, have the tool repaired before use.** Many accidents are caused by poorly maintained tools.
- e. **Use the tool, accessories and tool bits etc. In accordance with these instructions, taking into account the working conditions and the work to be performed.** Use of the tool for operations different from those intended could result in a hazardous situation.

Battery Use and Care

- a. Ensure the switch is in the off position before inserting the battery pack. Inserting the battery pack into power tools that have the switch on invites accidents.
- b. Recharge only with the charger specified by the manufacturer. A charger that is suitable for one type of battery pack may create a risk of fire when used with another battery pack.
- c. Use power tools only with specifically designated battery packs. Use of any other battery packs may create a risk of injury and fire.
- d. When the battery pack is not in use, keep it away from other metal objects like paper clips, coins, keys, nails, screws, or other small metal objects that can make a connection from one terminal to another. Shorting the battery terminals together may cause burns or a fire.
- e. Under abusive conditions, liquid may be ejected from the battery; avoid contact. If contact accidentally occurs, flush with water. If liquid contacts eyes, additionally seek medical help. Liquid ejected from the battery may cause irritation or burns.

Service

- a. Have your power tool serviced by a qualified trained person using only identical replacement parts. This will ensure that the safety of the power tool is maintained.
- b. **Tool service must be performed only by qualified trained personnel.** Service or maintenance performed by unqualified personnel may result in a risk of injury.
- c. When servicing a tool, use only identical replacement parts. Follow instructions in the Maintenance section of this manual. Use of unauthorized parts or failure to follow Maintenance Instructions may create a risk of shock or injury.

2. Functional Unit

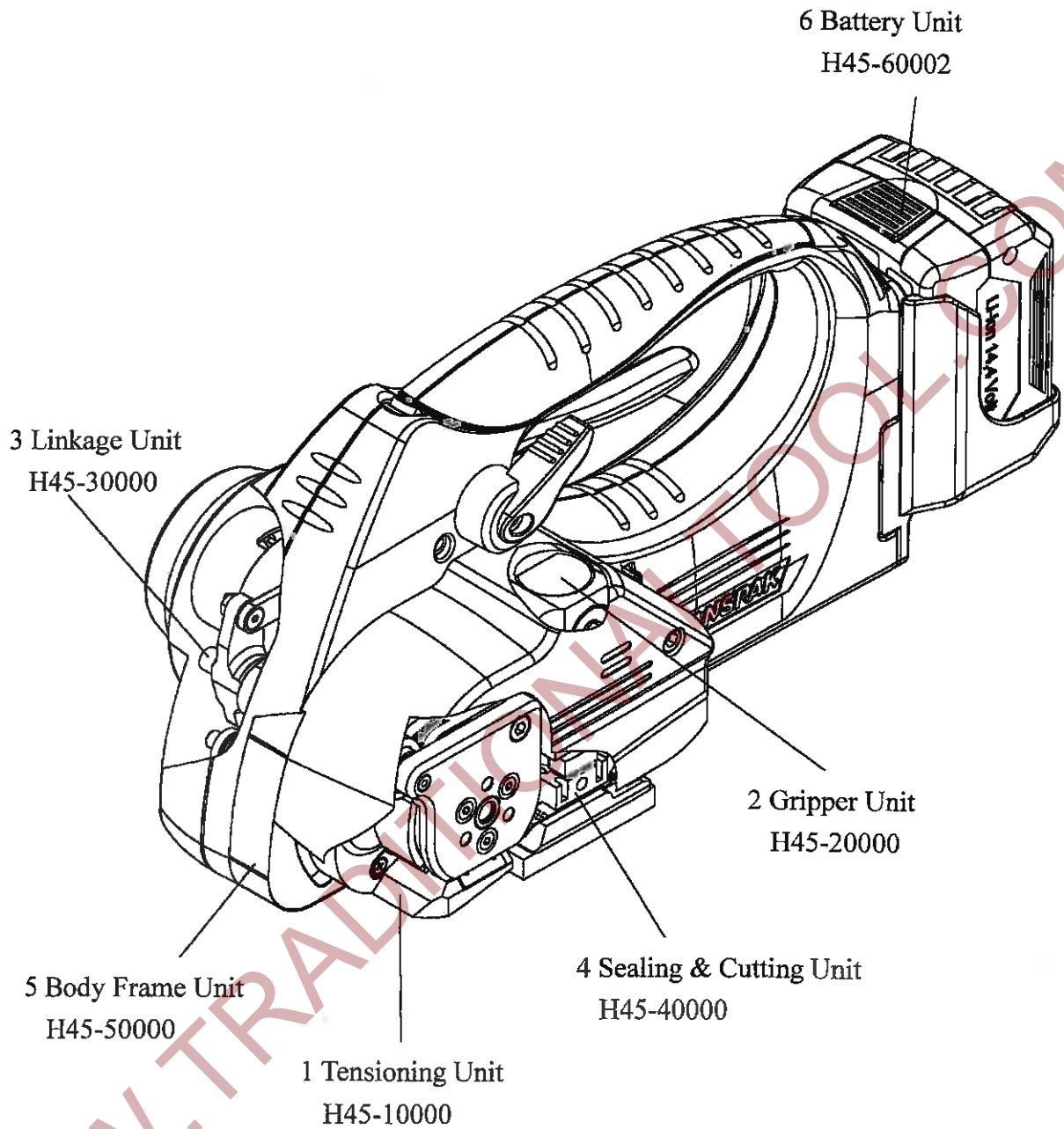

3. Technical Data

Battery Type <small>remarks</small>	BOSCH Li-Ion , 14.4VDC , 2.6Ah
Charging Time	About 30 minutes (after 20 minutes, approx. 70% charge capacity)
Strapping Speed	3 sec/cycle (Auto)
Strap Width	9mm, 12mm, 16mm
Strap Type	PET, PP
Strap Thickness	PET : 0.5mm-1.05mm PP : 0.55mm~1.05mm
Sealing Joint	friction weld
Vibration	7.77m/s ²
Noise emission	sound pressure level: 83.8dB(A) sound power level: 94.8dB(A)
Tension (max)	220 kg (485 lbs)
Dimensions (L)x(W)x(H)	350mm × 157mm × 160mm
Weight	4.26 kg (9.4 lbs)
Working Temperature	The ambient temperature should be between -5°C and 45°C (23 °F and 113°F) The best performance is achieved between 15°C and 20°C (59°F and 68°F)

Remarks:

If the tool will be idle for a long time, be sure to take out the battery to avoid reducing the battery's life span.

4. Operating Elements

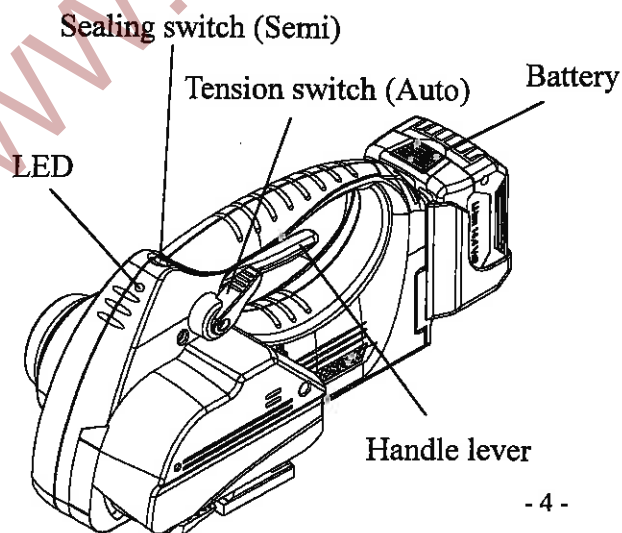

LED	
Red	Charge the battery
Yellow	Cooling time is running
Green	Strapping finish

LED Flash	
Green	Over Current
Green/Red	Over Heat

5. Operation

(1) Installation

Inserting the Battery

Insert the battery from the top downward to the bottom into the battery slot of the tool until hear the “click” sound. (refer to Fig. a) When the LED lights on GREEN shortly, the battery is installed correctly.

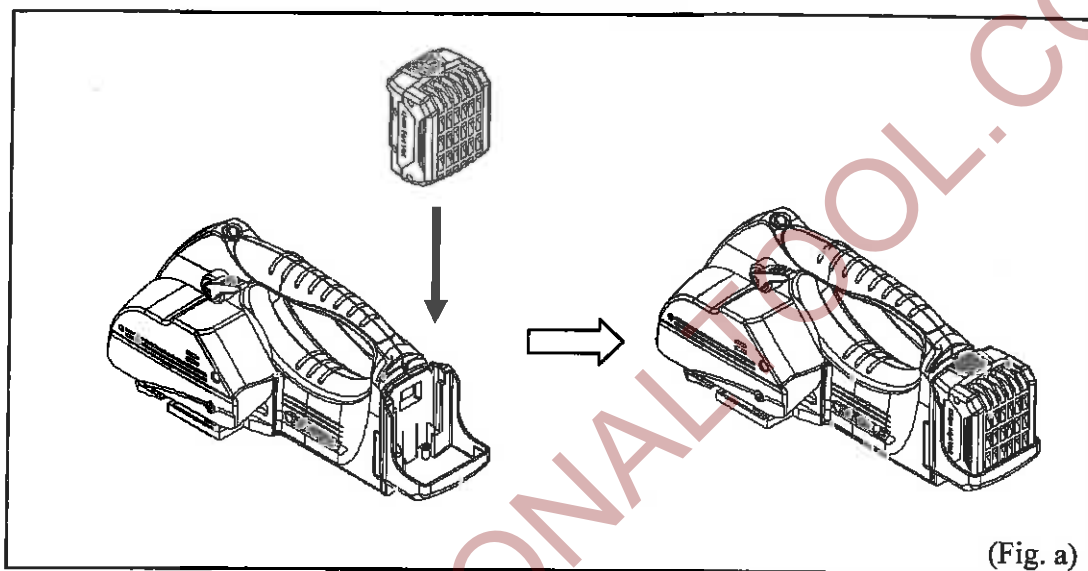

Removing the Empty Battery

If the LED lights on RED while tensioning or welding, that means the battery is exhausted. Please push the unlatching buttons (red color) on the top of the battery to take off the battery.

Warning!

The last welding on the package might not have sufficient seal efficiency and you would need to do it again after recharging the battery.

(2) Adjusting the Welding Pressure

In order to assure optimal welding, the pressure of the welding gripper to the straps to be welded must be within a certain range. Depending on the thickness of the strap, this pressure is adjusted by means of the adjusting the quantity of shim(s). Please see the following chart.



When adjusting the welding pressure, the shim must be inserted into "steel insert".

Disregarding this regulation will cause considerable trouble.

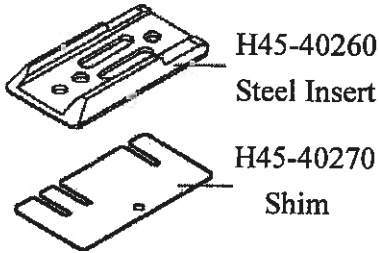

	smooth strap	embossed strap
strap thickness	quantity for shim(s) H45-40270	quantity for shim(s) H45-40270
0.5-0.6 mm (0.02"-0.024")	2	3
0.7-0.8 mm (0.028"-0.032")	1	2
0.9-1.05 mm (0.035"-0.041")	0	1

(3) Adjustments

(a) Preselecting of Strap Tension and Tensioning Speed

Do not adjust the tensioning force too high. If the tensioning force is higher than the strength of the strap, the strap will tear while tensioning. Tensioning force can be preselected with the left adjusting knob. Turning it clockwise increases the tensioning force, while turning it counterclockwise decreases the tensioning force.

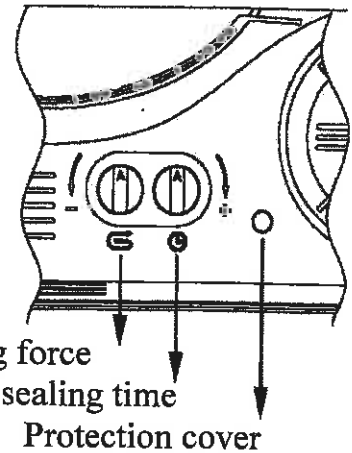

Adjusting knob for tensioning force

Adjusting knob for sealing time

Protection cover

When P.P. straps or straps with thinner thickness around 0.55mm to 0.7mm are still being damaged by H45-10090 (tension wheel) during strapping while the tension is at the lowest level (make a counterclockwise turn on the tension knob to the end), simply use an allen key wrench to make a counterclockwise turn on the trimmer of P.C. Board. You need to take off the protection cover first and you will then see the VR underneath the protection cover. After making all the adjustments, tension will become lower. When the tension becomes as low as you desired, just put the protection cover back. On the other hand, if tension is not enough while it is at the highest level (make a clockwise turn on the tension knob to the end), simple make a clockwise turn on the trimmer of P.C. Board for even higher tension.

When the tension becomes as low as you desired, just put the protection cover back. On the other hand, if tension is not enough while it is at the highest level (make a clockwise turn on the tension knob to the end), simply make a clockwise turn on the trimmer of P.C. Board for even higher tension.

(b) Adjusting the Sealing Time

Depending on the size and quality of the strap, different welding times are required. Turning the knob clockwise increases the welding time, while turning it counterclockwise decreases the welding time.

(4) Feeding the Strap Around the Package

The strapping is fed around the package as illustrated.



Warning! The plastic strap which will be welded must be free from oil, grease and other dirt. Dirty plastic straps can't be welded correctly!

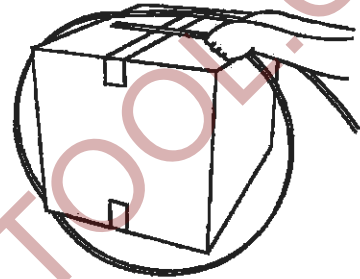

(5) Inserting the Strap

Pull up the handle lever firmly with your right hand. Insert the two straps well aligned on each other into the strap guide using your left hand. Release the handle lever.

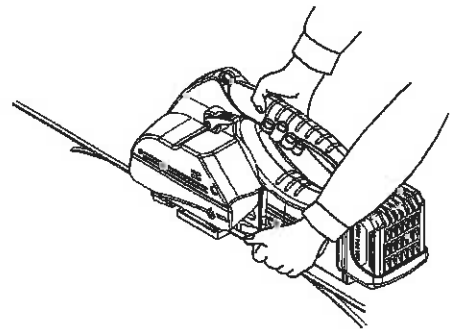

(6) Tensioning and Sealing the Straps

-Auto

Press down the rocker switch until the desired strap tension is reached. The tool will do sealing by itself. Release the rocker switch when it's finished.

-Semi

Press down the rocker switch and then release it, and press down again and again till the desired tension is reached.

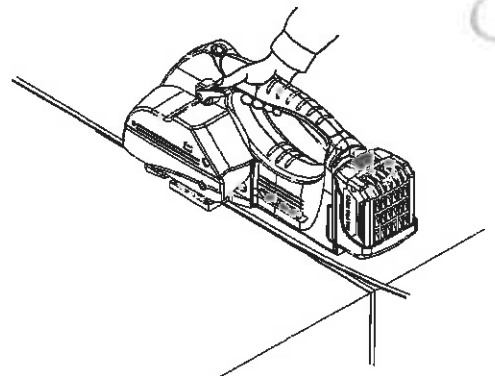

-Sealing the Straps

Press the black switch to sealing the straps.

The plastic strap is welded and cut off from the strap coil at the same time.

During welding, the LED lights green.

After expiration of the adjusted welding time, the cooling down time begins (LED lights yellow).

When the LED lights green again, the sealing procedure is finished.

(7) Removing the Tool

Pull up the handle lever, pull the tool right / backwards and off the strapping.

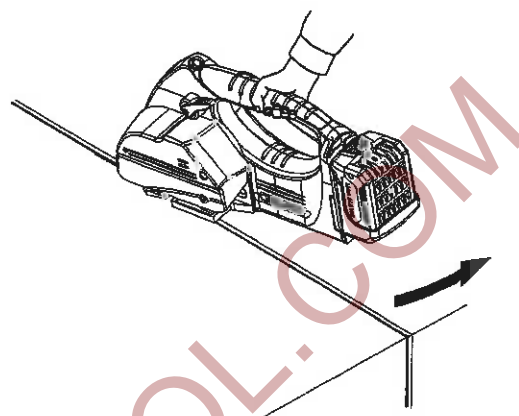

(8) Seal - Control

A regular control of the seal is necessary. The seal can be examined visually.

Make a seal, peel it apart and examine it as follows :

Correct Seal

The seal must be completely welded over the whole width of the strap on a length.

Minor quantities of fused plastic may overflow on sides.



Welding Time Too Short

The plastic strap is not welded over the whole width of the strap.

The seal efficiency is insufficient.

Warning! Straps with insufficient seal strength must be removed from the package!

Adjust the welding time.



Welding Time Too Long

If the welding time is too long the straps are overheated.

The fused plastic overflows on both sides of the straps.

The seal efficiency is affected.

Warning! Straps with insufficient seal strength must be removed from the package!

Adjust the welding time.



6. Maintenance

Please take off the battery before doing maintenance.

- (1) Use air gun to clean the area around Tensioning Wheel (H45-10090) and Gripper (H45-10070/H45-10071) and the area around Cutter (H45-40090) daily. Be sure to use the air gun by blowing the debris from the left side to avoid any debris blowing to inside of the tool.

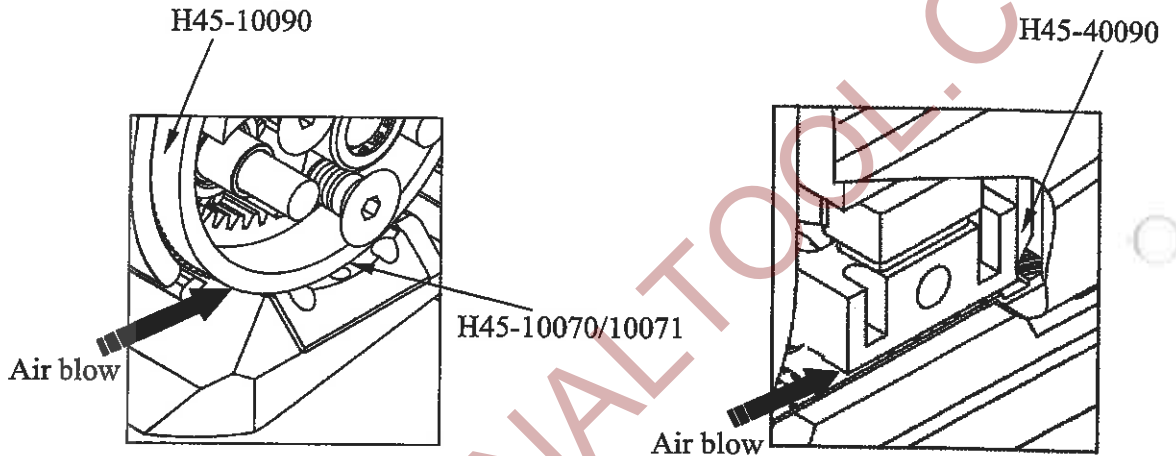

- (2) If air gun could not dislodge the debris between the teeth of Tensioning Wheel (H45-10090), it is suggested to sharp the tip of PET (or other plastic) strap and use it as a tool to clean the strap debris.

Please do not use any metal material or hard material to clean the teeth to avoid any damage to the teeth.

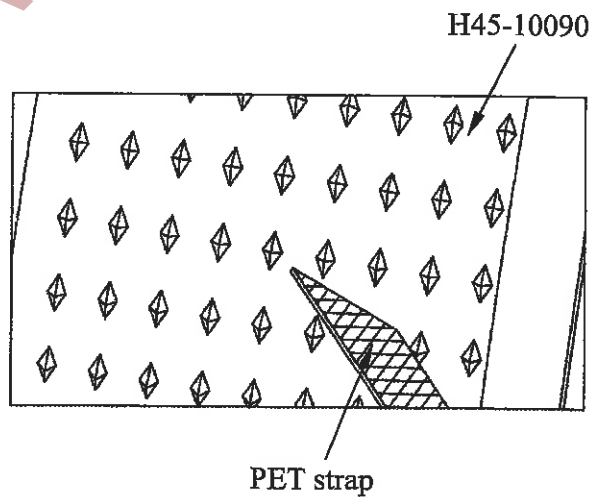

(3) DISPOSAL

The power tool, accessories and packaging materials should be sorted for environmental-friendly recycling.

Do not dispose of power tools into household waste!

According the European Guideline 2002/96/EC for Waste Electrical and Electronic Equipment and its implementation into national right, power tools that are no longer usable must be collected separately and disposed of in an environmentally correct manner.



7. Troubleshooting

(1) The strap slips while tensioning

- Tension force setting is higher than the Strap Strength. Please turn down the tension (refer to Page no.6 in Part I of Manual).
- There is too much strap debris on the teeth of the Tensioning Wheel (H45-10090) or Gripper (H45-10070)
- Strap Stop (H45-10280/H45-10281) touches the straps. (shown as following drawing). Please clean the Strap Stop (H45-10280) and feed the strap appropriately until the Strap Stop won't affect the strap while tension.

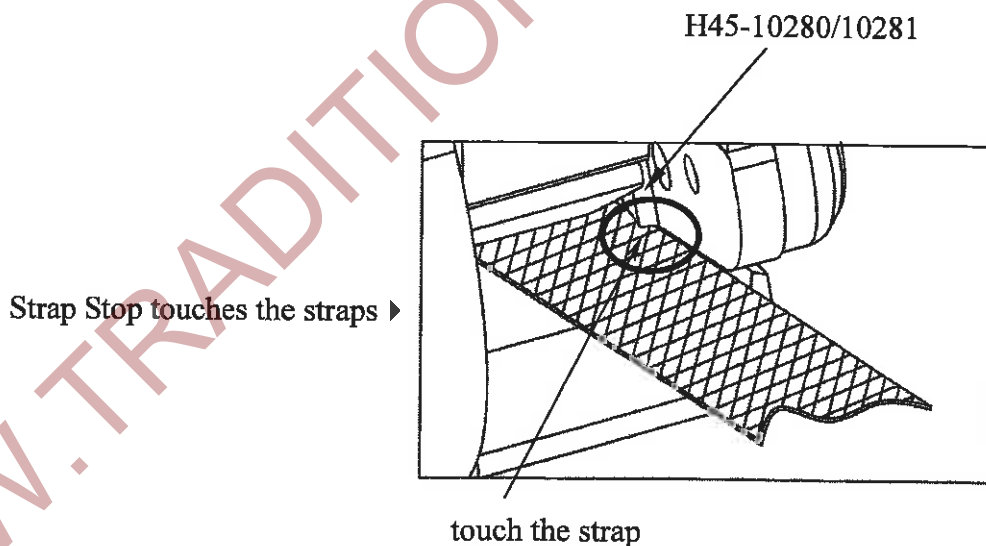









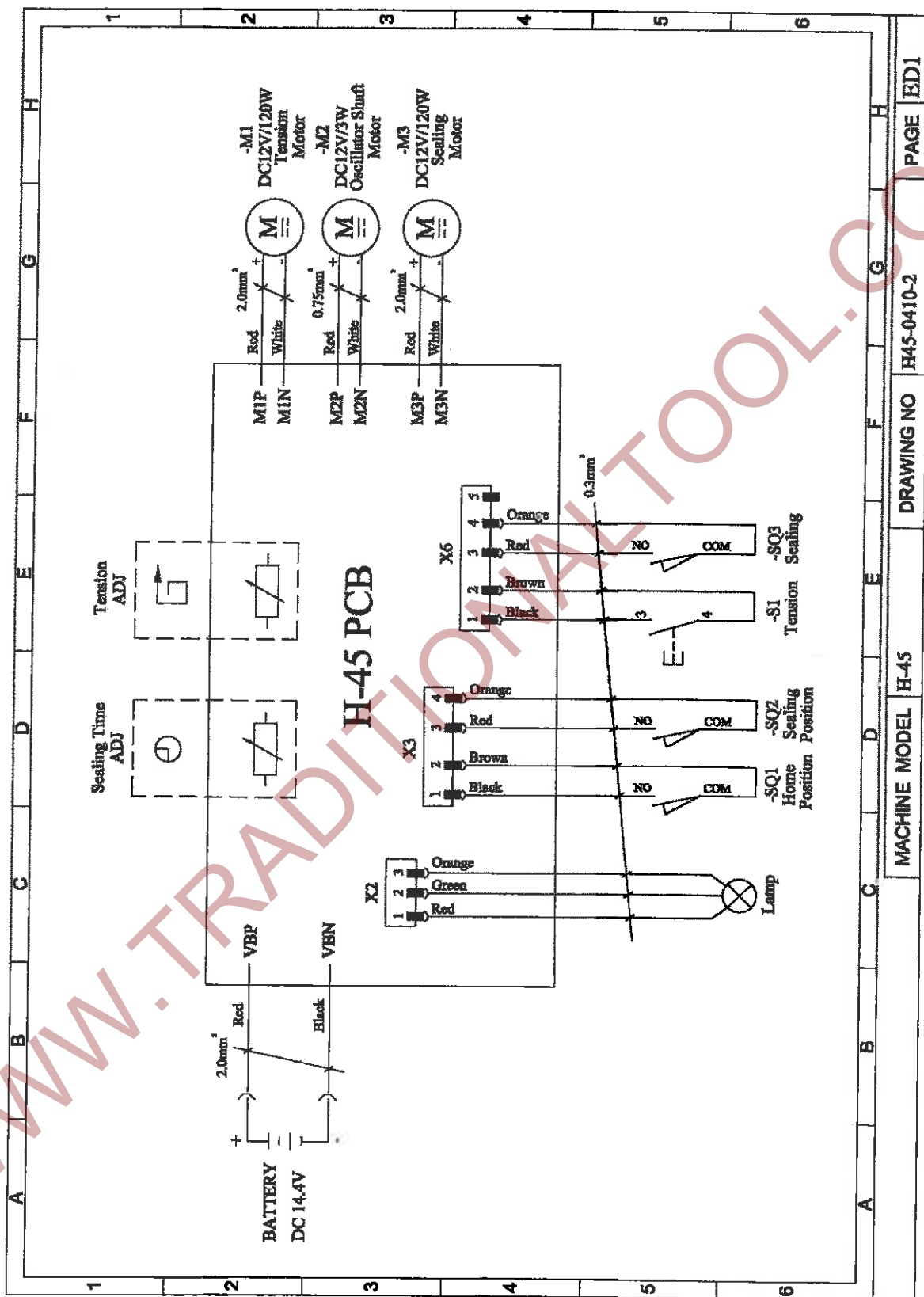





























- The Tensioning Wheel (H45-10090) or the Gripper's (H45-10070/ H45-10071) teeth is worn and need replacement.

(2) The strap can not be cut completely

- The sealing time might be set too short.
- The strap is not thread correctly so a small part of the strap is not cut completely.
- The Shim (H45-40270) are too many or insufficient.
- The Cutter (H45-40090) is worn.

8. Wiring Diagram



shape	classification	shape	classification
	HBS		SR
	TMS		SP
	PMS		BR
	FMS		BK single cover
	HB		KT
	THS		HFL one way
	HSS		TAL
	CAP		MB
	HN		KYA
	WN		KYB
	FLG		KYC
	NTE		HBW
	PN		PWA φ 8x φ 12~ φ 16x0.8~1.2t φ 6x φ 13~ φ 14x0.8~1.2t
	PW		PWB φ 8x φ 14~ φ 16x1.2~1.5t φ 6x φ 15~ φ 16x1.2~1.5t
	SW		PWC φ 8x φ 20~ φ 23x2.0t φ 6x φ 16~ φ 19x2.0t
	TW		DS
	BWW		TTP
	ER		FTP
	RR		FHS

PART II

CONTENTS

1. Tensioning Unit	1
2. Gripper Unit	4
3. Linkage Unit.....	6
4. Sealing & Cutting Unit	8
5. Body Frame Unit	11
6. Battery Unit.....	13

WWW.TRADITIONALTOOL.COM

1

TENSIONING UNIT

H45-10001
H45-10002

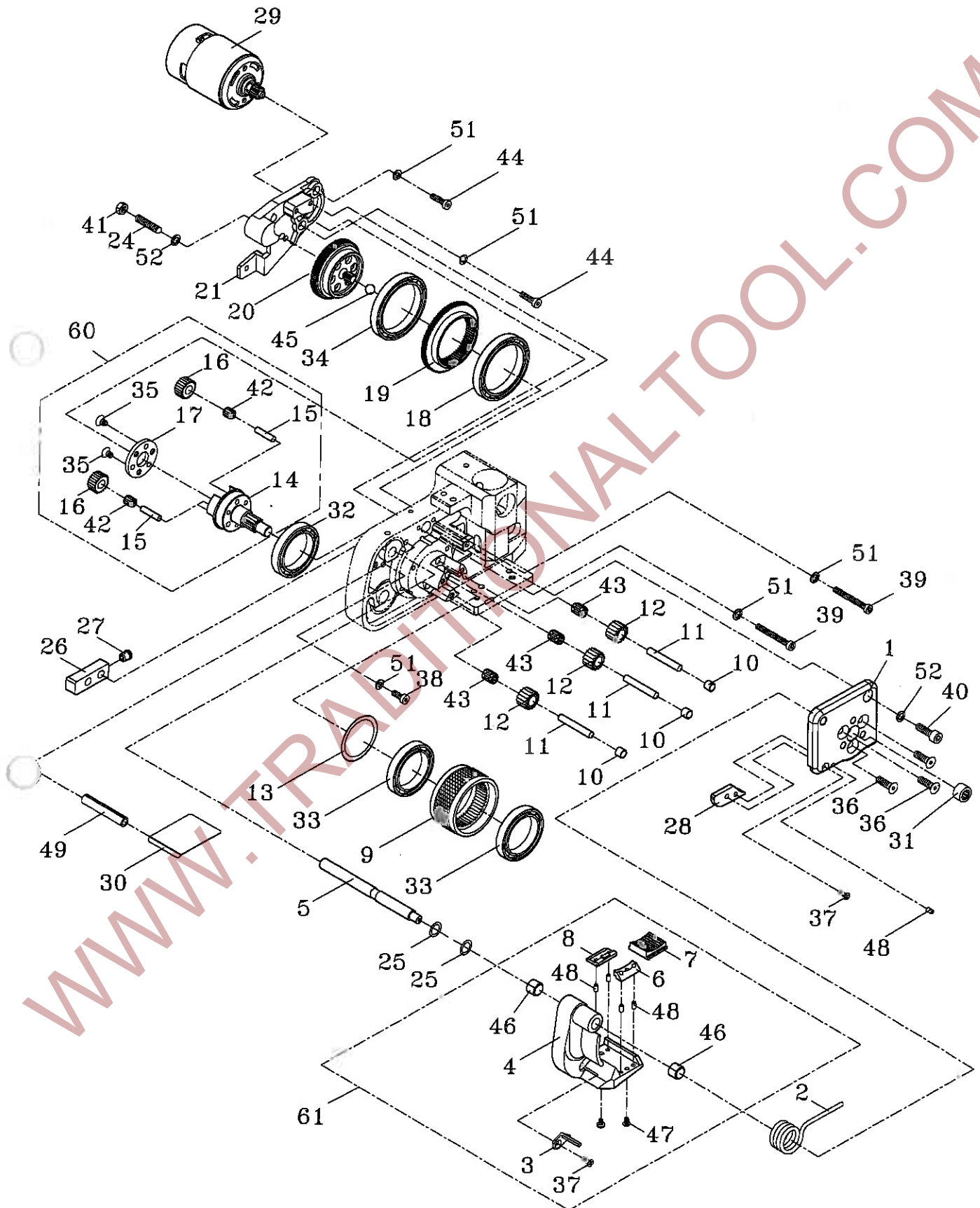

1

TENSIONING UNIT

H45-10001

H45-10002

REF. NO.	PART NO.	DESCRIPTION	Q'TY	REMARKS
	H45-10001	Tensioning Unit (For 12mm)	1	
	H45-10002	Tensioning Unit (For 16mm)	1	
	H45-10003	Tensioning Unit (For 9mm)	1	
1	H45-10010	End Cover	1	
2	MSP-T-2822601	Torsion Spring	1	
3	H45-10030	Strap Stop (For 16mm)	1	
	H45-10031	Strap Stop (For 9mm/12mm)	1	
4	H45-10040	Tensioning Body	1	
5	H45-10050	Swivel Shaft	1	
6	H45-10060	Holder	1	
7	H45-10072	Gripper	1	
8	H45-10081	Holder	1	
9	H45-10090	Tensioning Wheel	1	
10	H45-10100	Dowel	3	
11	H45-10110	Parallel Pin	3	
12	H45-10120	Idler Gear	3	
13	H45-10130	Washer	1	
14	H45-10140	Tensioning Wheel Shaft	1	
15	H45-10150	Parallel Pin	3	
16	H45-10160	Idler Gear	3	
17	H45-10170	Cover	1	
18	H45-10180	Bearing	1	
19	H45-10190	Tension Gear	1	
20	H45-10200	Spur Wheel	1	
21	H45-10210	M1 Motor Support	1	
24	H45-10240	Screw	1	
25	H45-10250	Washer	2	
26	H45-10260	Tube	1	
27	H45-10270	Set Ball	1	
28	H45-10280	Strap Stop (For 12mm/16mm)	1	
	H45-10281	Strap Stop (For 9mm)	1	
29	H45-10290	M1 Motor Ass'y	1	

1

TENSIONING UNIT

H45-10001

H45-10002

REF. NO.	PART NO.	DESCRIPTION	Q'TY	REMARKS
30	H45-10300	Cover	1	
31	BK0808Z	Needle Bearing, 0808Z	1	
32	BR6806	Bearing, 6806	1	
33	BR6806Z	Bearing, 6806Z	2	
34	BR6808Z	Bearing, 6808Z	1	
35	FHS0408N	FHS, M4×8 (N)	3	
36	FHS0514N	FHS, M5×14 (N)	3	
37	FHS0308N	FHS, M3×8 (N)	2	
38	HBS0410N	HBS, M4×10 (N)	2	
39	HBS0430HN	HBS, M4×30 (H)(N)	2	
40	HBS0516N	HBS, M5×16 (N)	1	
41	HN05	HN, M5	1	
42	KT-477N	Needle Bearing, 477N	3	
43	KT-5810N	Needle Bearing, 5810N	3	
44	HBS0412N	HBS, M4×12 (N)	2	
45	SB04	Ball, Ø4	1	
46	MB0815	Metal Bushing, 0815	2	
47	FHS0306N	FHS, M3×6 (N)	2	
48	SP0306	Spring Pin, 3×6	5	
49	SP0432	Spring Pin, 4×32	1	
51	SW04	SW, M4	6	
52	SW05	SW, M5	2	
60	H45-10600	Tensioning Wheel Shaft Ass'y	1	
61	H45-10700	Tensioning Body Ass'y (For 16mm)	1	
	H45-10701	Tensioning Body Ass'y (For 9mm/12mm)	1	

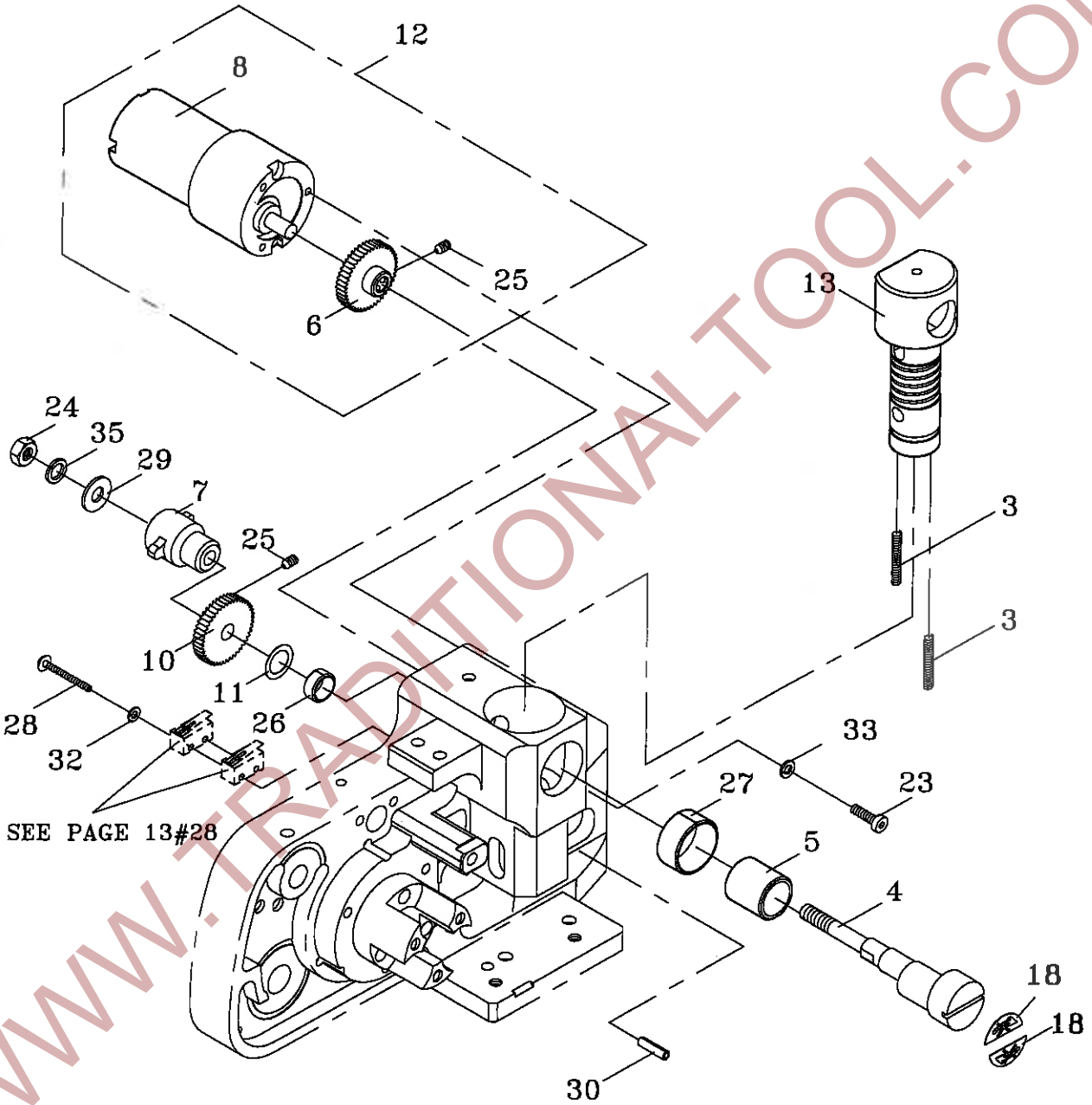

2

GRIPPER UNIT

H45-20000

REF. NO.	PART NO.	DESCRIPTION	Q'TY	REMARKS
3	H45-20030	Spring	2	
4	H45-20041	Eccentric Shaft	1	
5	H45-20050	Inner Raceway	1	
6	H45-20060	M2 Motor Gear	1	
7	H45-20070	Switch Rocker	1	
8	H45-20080	M2 Motor	1	
10	H45-20100	Eccentric Shaft Gear	1	
11	H45-10250	Washer	1	
12	H45-20120	M2 Motor Ass'y	1	
13	H45-20111	Spring Slide Ass'y	1	
18	LA-40220	Label	2	
23	HBS0320N	HBS, M3×20 (N)	1	
24	HN05	HN, M5	1	
25	HSS0305	HSS, M3×5	4	
26	MB0805	Metal Bushing, 0805	1	
27	MB1709	Metal Bushing, 1709	1	
28	PMS0218	PMS, M2×18	2	
29	PW05B	PW, M5 (B) Ø13	1	
30	SP0310	Spring Pin, 3×10	1	
32	SW02	SW, M2	2	
33	SW03	SW, M3	1	
35	SW05	SW, M5	1	

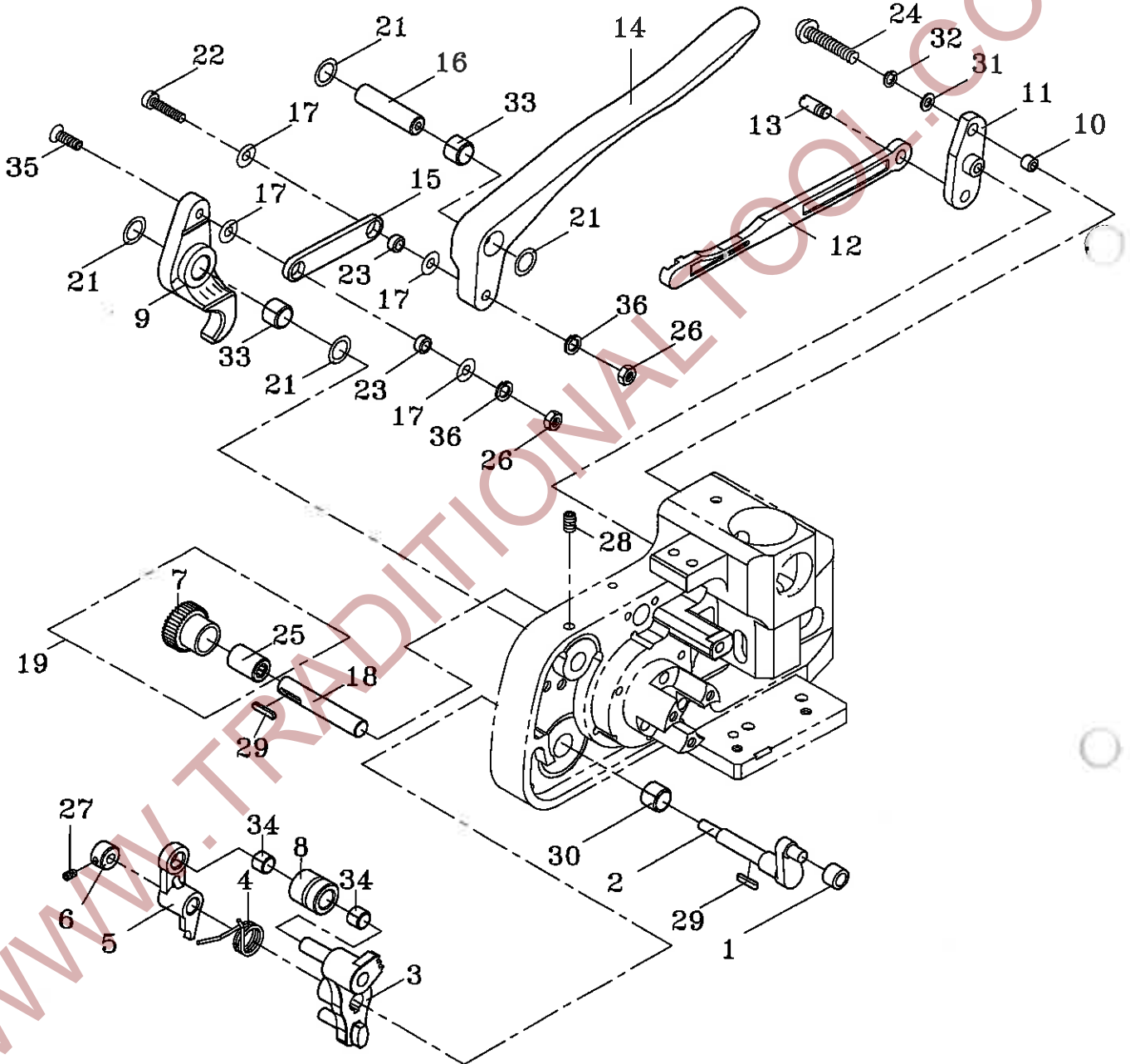

3

LINKAGE UNIT

H45-30000

REF. NO.	PART NO.	DESCRIPTION	Q'TY	REMARKS
1	H45-30010	Pressure Roller	1	
2	H45-30020	Front Toggle Link	1	
3	H45-30030	Lever	1	
4	H45-30040	Torsion Spring	1	
5	H45-30050	Stanchion	1	
6	H45-30060	Collar	1	
7	H45-30070	Spur Wheel	1	
8	H45-30080	Collar	1	
9	H45-30090	Handle Arm	1	
10	H45-30100	Collar	1	
11	H45-30110	Arm	1	
12	H45-30120	Coupler	1	
13	H45-30130	Coupler Shaft	1	
14	H45-30140	Handle Lever	1	
15	H45-30151	Connector	1	
16	H45-30160	Handle Shaft	1	
17	H45-30170	Washer	4	
18	H45-30180	Shaft	1	
19	H45-30190	Spur Wheel Ass'y	1	
21	H45-10250	Washer	4	
22	HBS0420N	HBS, M4×20 (N)	1	
23	H45-30230	Collar	2	
24	PMS0312	PMS, M3×12	1	
25	HFL0615	Bearing, 6×10×15	1	
26	NTE04	NTE, M4	2	
27	HSS0305	HSS, M3×5	1	
28	HSS0508G	HSS, M5×8 (G)	2	
29	KYA020210	Key, 2×2×10	2	
30	MB0810	Metal Bushing, 0810	1	
31	PW03	PW, M3	2	
32	SW03	SW, M3	1	
33	MB0812	Metal Bushing, 0812	2	
34	MB0606	Metal Bushing, 0606	2	
35	FMS0420	FMS, M4×20	1	
36	SW04	SW, M4	2	

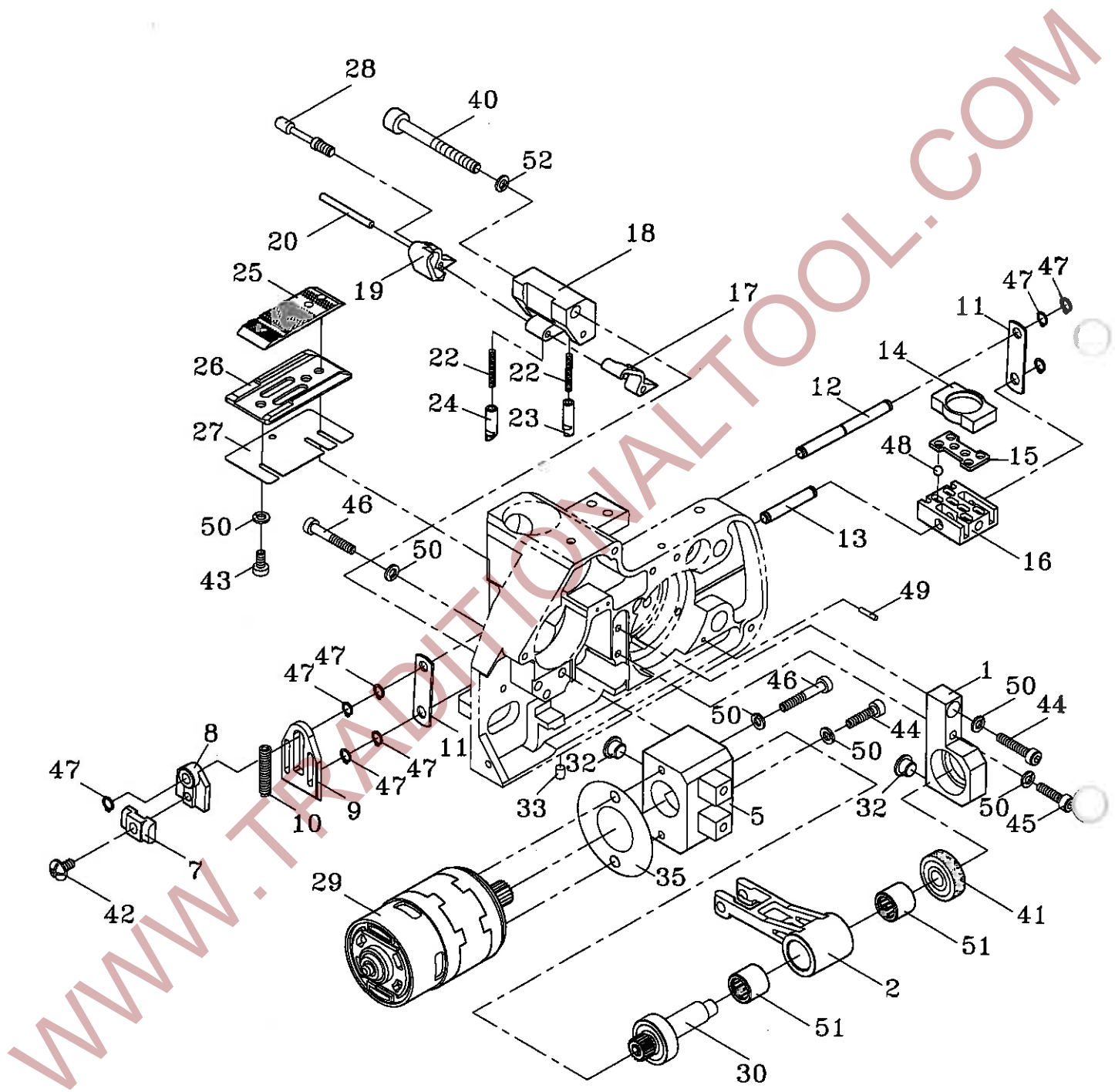

REF. NO.	PART NO.	DESCRIPTION	Q'TY	REMARKS
	H45-40001	Sealing & Cutting Unit (For 12mm)	1	
	H45-40002	Sealing & Cutting Unit (For 16mm)	1	
	H45-40003	Sealing & Cutting Unit (For 9mm)	1	
1	H45-40011	Bearing Support	1	
2	H45-40020	Rocker	1	
5	H45-40051	M3 Motor Support	1	
7	H45-40070	Thrust Piece	1	
8	H45-40080	Coupler	1	
9	H45-40090	Cutter	1	
10	H45-40100	Pressure Spring	1	
11	H45-40110	Driver	2	
12	H45-40120	Driver Pin	1	
13	H45-40130	Bolt	1	
14	H45-40140	Thrust Piece	1	
15	H45-40150	Ball Cage	1	
16	H45-40160	Welding Gripper	1	
17	H45-40170	Seesaw Lever (In Side)	1	
18	H45-40180	Guide Case	1	
19	H45-40190	Seesaw Lever (Out Side)	1	
20	H45-40200	Parallel Pin	1	
22	H45-40220	Pressure Spring	2	
23	H45-40230	Guide Pin (For 16mm)	1	
	H45-40231	Guide Pin (For 9mm/12mm)	1	
24	H45-40240	Guide Pin (For 12mm/16mm)	1	
	H45-40231	Guide Pin (For 9mm)	1	
25	H45-40250	Welding Stop Gripper	1	
26	H45-40260	Steel Insert	1	
27	H45-40270	Shim		
		Strap Thickness 0.4~0.6mm	2	
		Strap Thickness 0.7~0.8mm	1	
		Strap Thickness 0.9~1.05mm	0	
28	H45-40280	Shaft	1	

REF. NO.	PART NO.	DESCRIPTION	Q'TY	REMARKS
29	H45-40290	M3 Motor Ass'y	1	
30	H45-40300	Welding Excentric Ass'y	1	
32	T7-5-20210	Grommet	2	
33	H44-10710	Lock Pin, 4×8	1	
35	H45-40340	Cover	1	
40	HBS0545HN	HBS, M5×45 (H)(N)	1	
41	BR627ZZ	Bearing, 627ZZ	1	
42	TMS0408	TMS, M4×8	1	
43	HBS0408N	HBS, M4×8 (N)	2	
44	HBS0416N	HBS, M4×16 (N)	2	
45	HBS0420N	HBS, M4×20 (N)	1	
46	HBS0425N	HBS, M4×25 (N)	3	
47	SR05	Snap Ring, S-5	8	
48	SB04	Ball, Ø4	6	
49	SP0318	Spring Pin 3×18	1	
50	SW04	SW, M4	8	
51	TAL1012	Needle Bearing, 1012	2	
52	SW05	SW, M5	1	

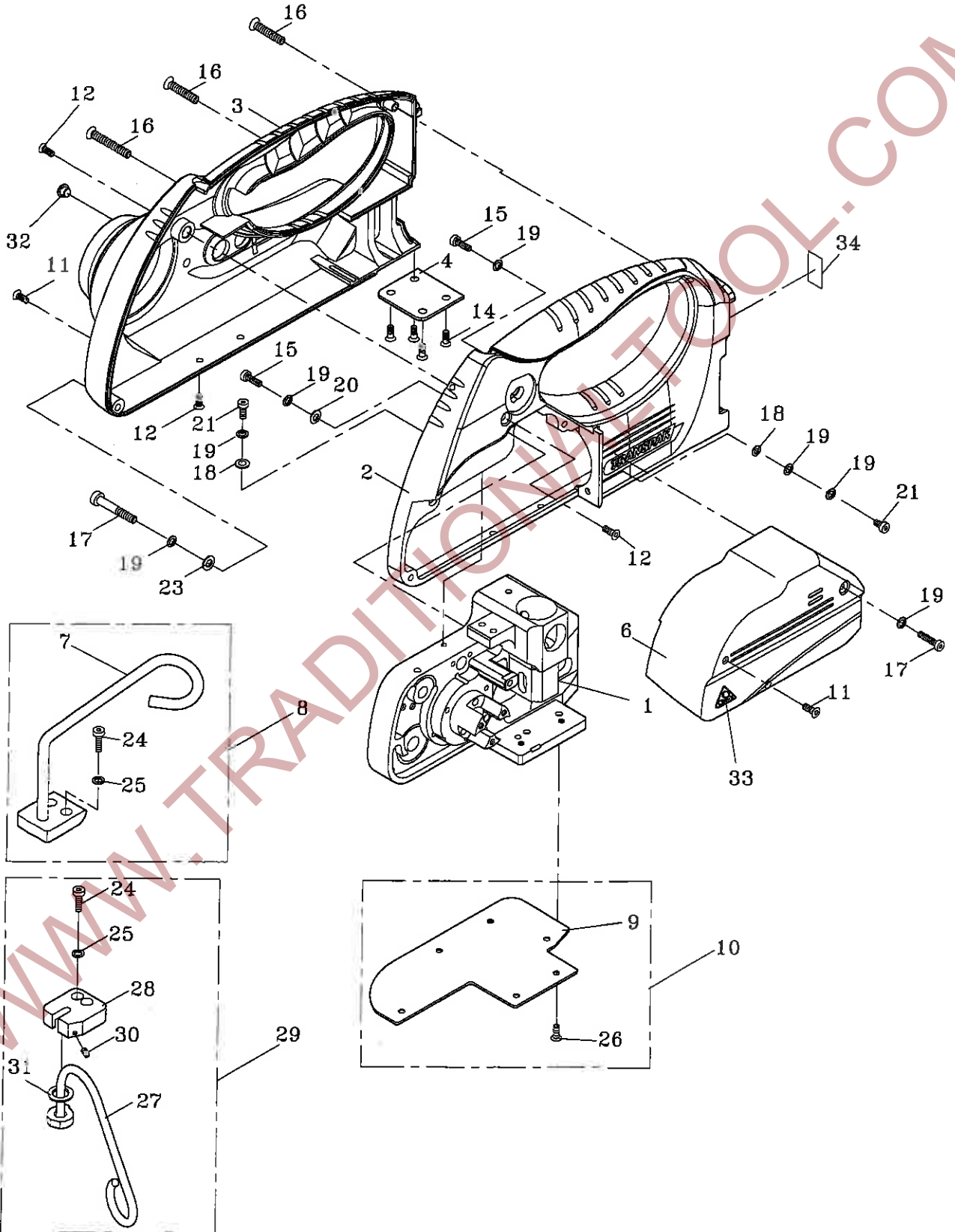

REF. NO.	PART NO.	DESCRIPTION	QTY	REMARKS
1	H45-50010	Body Frame	1	
2	H45-50021	Cover Front	1	
	H45-50022	Cover Front (Black)(Option)	1	
3	H45-50030	Cover Rear	1	
	H45-50031	Cover Rear (Black)(Option)	1	
4	H45-50040	Plate	1	
6	H45-50060	Cover	1	
7	H45-50070	Stiff Suspension Bracket (Option)	1	
8	H45-50080	Stiff Suspension Bracket Set (Option)	1	
9	H45-50090	Bottom Base Wearing Protection Plate (Option)	1	
10	H45-50100	Bottom Base Wearing Protection Plate Set (Option)	1	
11	FHS0310N	FHS, M3×10 (N)	2	
12	FHS0410N	FHS, M4×10 (N)	6	
14	FTP0410BN	FTP, M4×10 (B)(N)	4	
15	HBS0416N	HBS, M4×16 (N)	2	
16	TTP0420BN	TTP, M4×20 (B)(N)	3	
17	HBS0440HN	HBS, M4×40 (H)(N)	2	
18	PW04	PW, M4	2	
19	SW04	SW, M4	7	
20	H45-50160	Washer (M4× ϕ 8×0.8t)	1	
21	HBS0410N	HBS, M4×10 (N)	2	
23	PW04S	PW, M4 (SUS)	1	
24	HBS0516N	HBS, M5×16 (N)(Option)	4	
25	SW05	SW, M5 (Option)	4	
26	FHS0410N	FHS, M4×10 (N)(Option)	6	
27	H45-50110	Turnable Suspension Bracket (Option)	1	
28	H45-50140	Block (Option)	1	
29	H45-50150	Turnable Suspension Bracket Set (Option)	1	
30	HSS0410GN	HSS, M4×10 (G)(N)(Option)	1	
31	AD-2-20181	Washer (Option)	1	
32	T7-5-20210	Grommet	1	
33	LA-40010	Label	1	
34	LA-50008	Label	1	

6

BATTERY UNIT

H45-60002
H45-60003

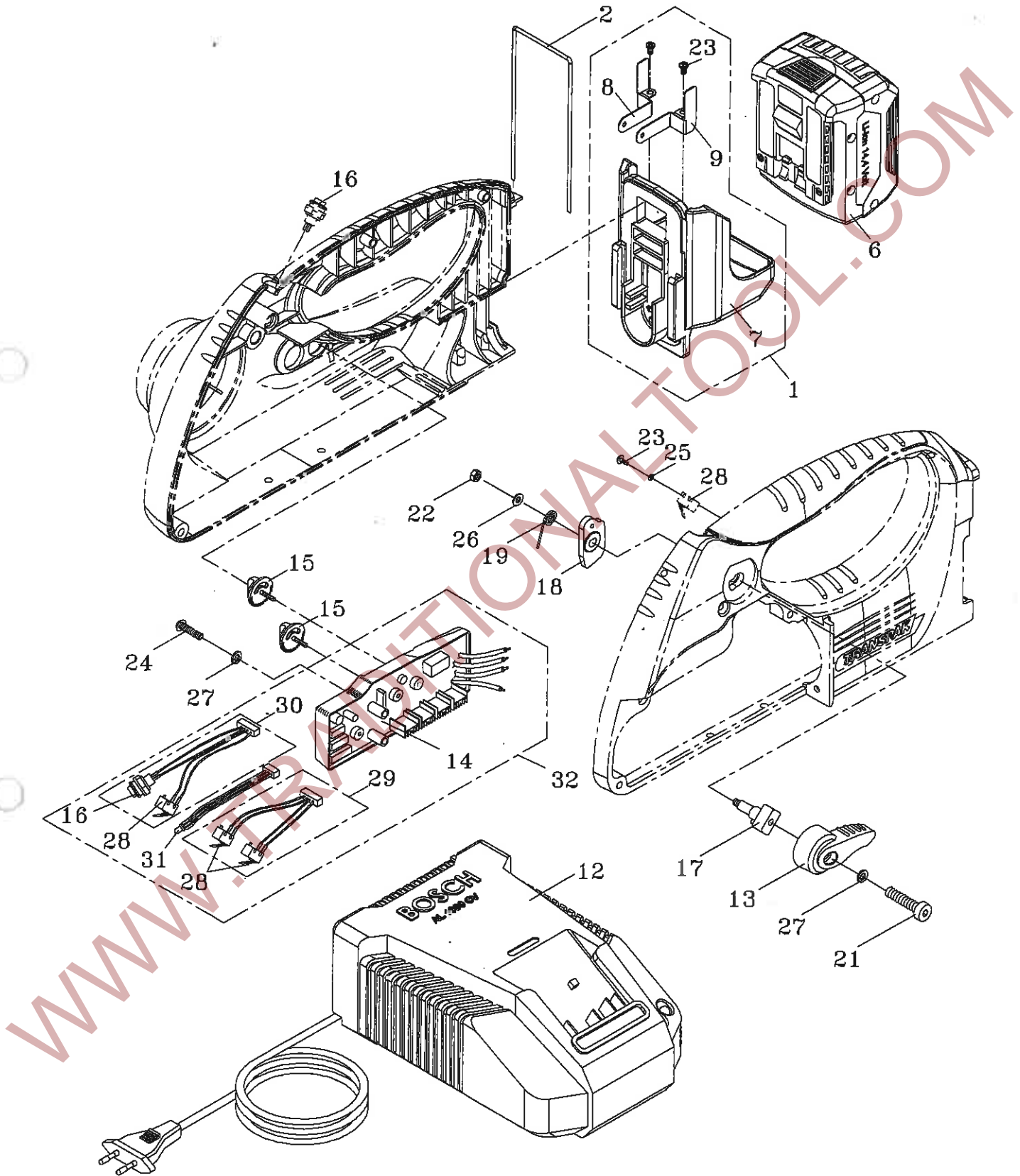

6

BATTERY UNIT

H45-60002

H45-60003

REF. NO.	PART NO.	DESCRIPTION	Q'TY	REMARKS
	H45-60002	Battery Unit (For 220V/230V/240V)	1	
	H45-60003	Battery Unit (For 110V)	1	
1	H45-50210	Adapter Set	1	
	H45-50215	Adapter Set (Black)(Option)	1	
2	H45-50200	Battery Lock Pin	1	
6	H45-60270	Bosch Battery (Li-Ion)	1	
7	H45-50170	Adapter Frame	1	
	H45-50175	Adapter Frame (Black)(Option)	1	
8	H45-50180	Adapter Pole (Right)	1	
9	H45-50190	Adapter Pole (Left)	1	
12	H45-60280	Li-Ion Battery Charger (For 110V)	1	
	H45-60290	Li-Ion Battery Charger (For 220V/230V/240V)	1	
13	H45-60130	Tension Switch (Auto)	1	
14	H45-60143	Control Box (PCB)	1	
15	H45-60150	Knob	2	
16	H45-60160	Sealing Switch (Semi)	1	
17	H45-60171	Lock	1	
18	H45-60182	Cam	1	
19	H45-60190	Spring	1	
21	HBS0412N	HBS, M4×12 (N)	1	
22	NTE05	NTE, M5	1	
23	TTP0305	TTP, M3×5	4	
24	PMS0430	PMS, M4×30	2	
25	PW03	PW, M3	2	
26	MWA-A-0510050	Washer	1	
27	SW04	SW, M4	3	
28	H45-20090	Micro Switch	3	
29	H45-60210	Position Wires Ass'y	1	
30	H45-60220	Start/Sealing Wires Ass'y	1	
31	H45-60230	LED Wire	1	
32	H45-60241	Electric Control Group	1	

02/2014

WWW.TRADITIONALTOOL.COM

WWW.TRADITIONALTOOL.COM